

Sep.1.2024 Copyright 2024 HIROSE ELECTRIC CO., LTD. All Rights Reserved.
In case of consideration for using Automotive equipment / device which demand high reliability, kindly contact our sales window correspondents.

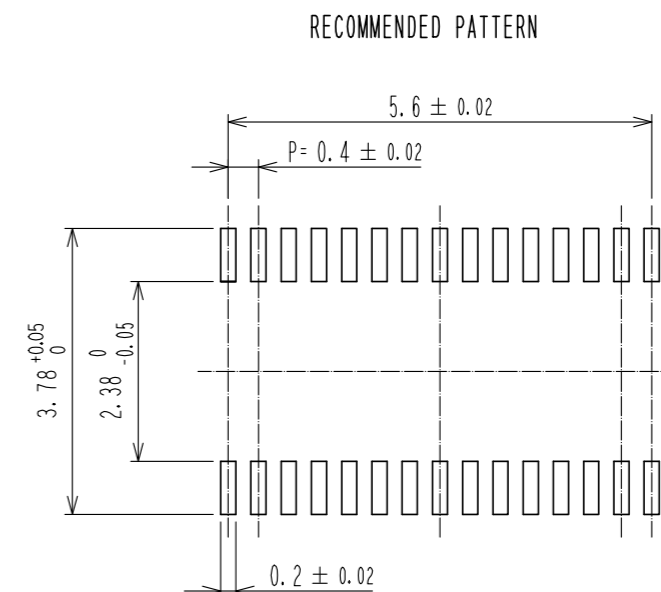

RECOMMENDED METAL MASK THICKNESS: 120 μm
RECOMMENDED MASK OPENING RATIO: 80% FOR LEAD PAD

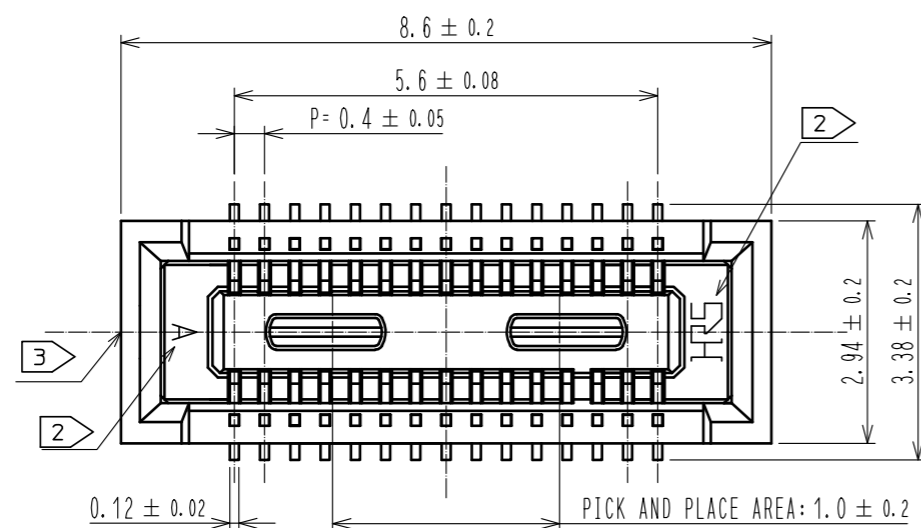
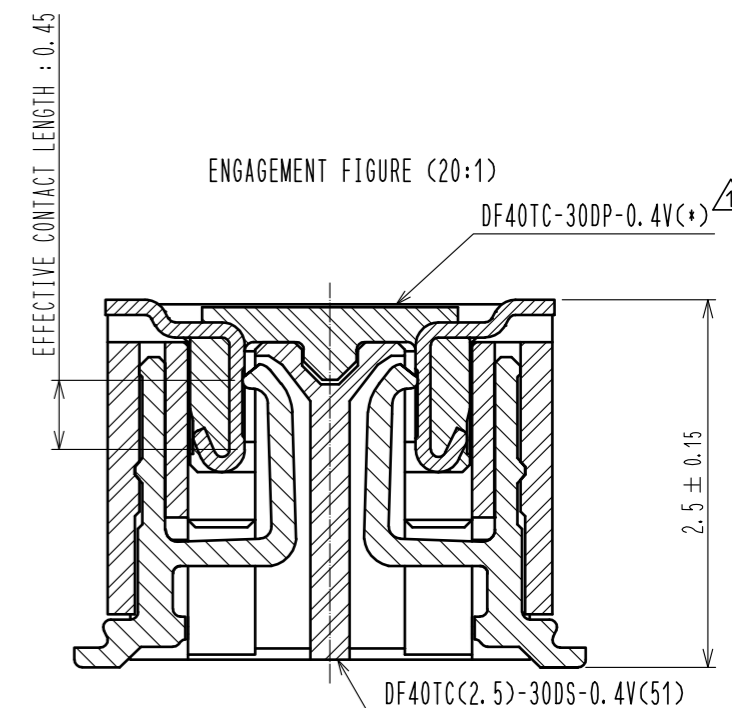
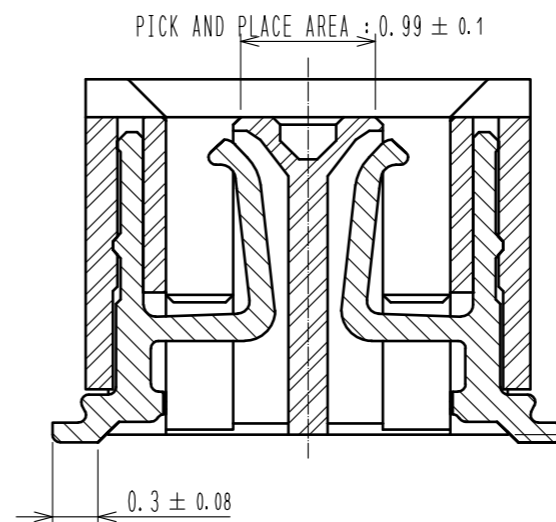
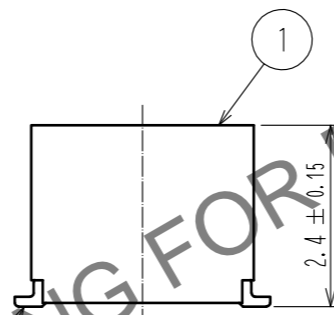
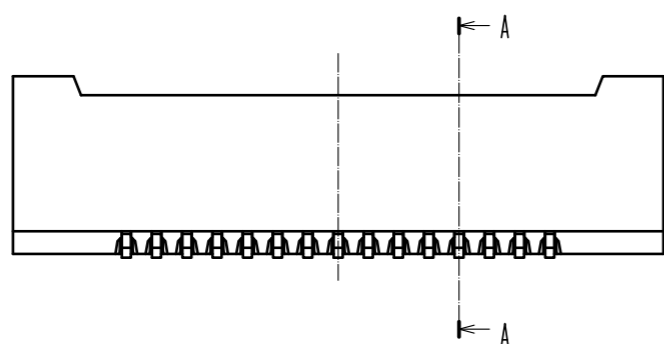

NOTES) 1. ALL LEADS CO-PLANARITY SHALL BE 0.1mm MAX.
2 HRS MARK AND CAV NO. ARE LOCATED IN APPROXIMAL AREA.
3 GATE IS COCATED IN APPROXIMAL AREA.

2	COPPER ALLOY	CONTACT AREA: GOLD 0.05 μm MIN	6	PS	CLEAR, REINFORCEMENT COLLAR		
		SMT LEAD: GOLD 0.05 μm MIN	5	PS	BLACK, PLASTIC REEL		
		UNDERPLATING: NICKEL 1 μm MIN	4	POLYESTER	CLEAR, COVER TAPE		
1	LCP	BLACK, UL94V-0	3	PS	CLEAR, EMBOSSED CARRIER TAPE		
NO.	MATERIAL	FINISH, REMARKS	NO.	MATERIAL	FINISH, REMARKS		
UNITS mm		SCALE 10:1	COUNT 1	DESCRIPTION OF REVISIONS DIS-H-00015513	DESIGNED YK. SATAKE	CHECKED RT. SHIMIZU	DATE 20220930
HRS HIROSE ELECTRIC CO., LTD.		APPROVED: WR. FUKUCHI	20211006	DRAWING NO. EDC-386697-51-00			
		CHECED: TS. MIYAZAKI	20211006	PART NO. DF40TC(2.5)-30DS-0.4V(51)			
		DESIGNED: YK. SATAKE	20211006	CODE NO. CL0684-4266-0-51			
		DRAWN: YK. SATAKE	20211006				

Sep.1.2024 Copyright 2024 HIROSE ELECTRIC CO., LTD. All Rights Reserved.
In case of consideration for using Automotive equipment / device which demand high reliability, kindly contact our sales window correspondents.

EMBOSSED CARRIER TAPE PACKAGING (5:1)

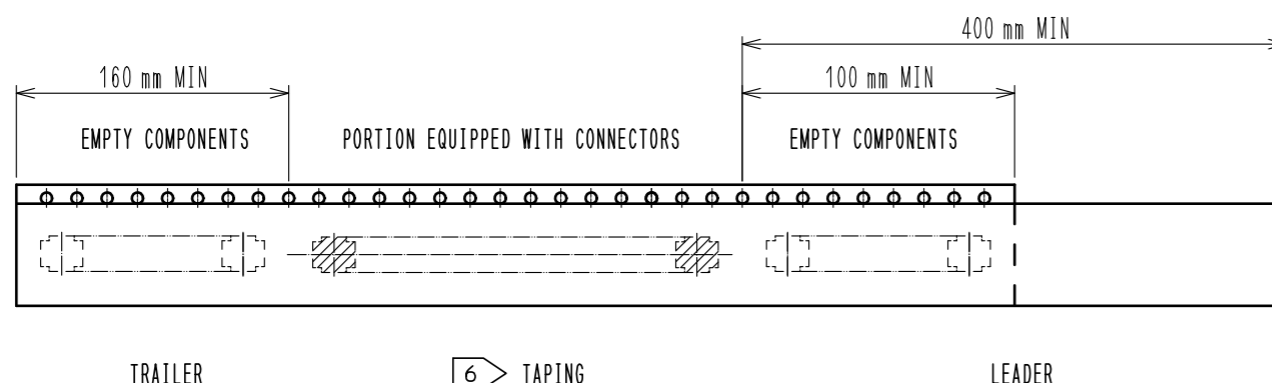
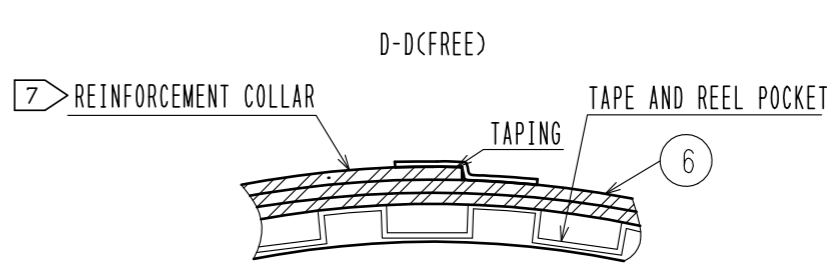
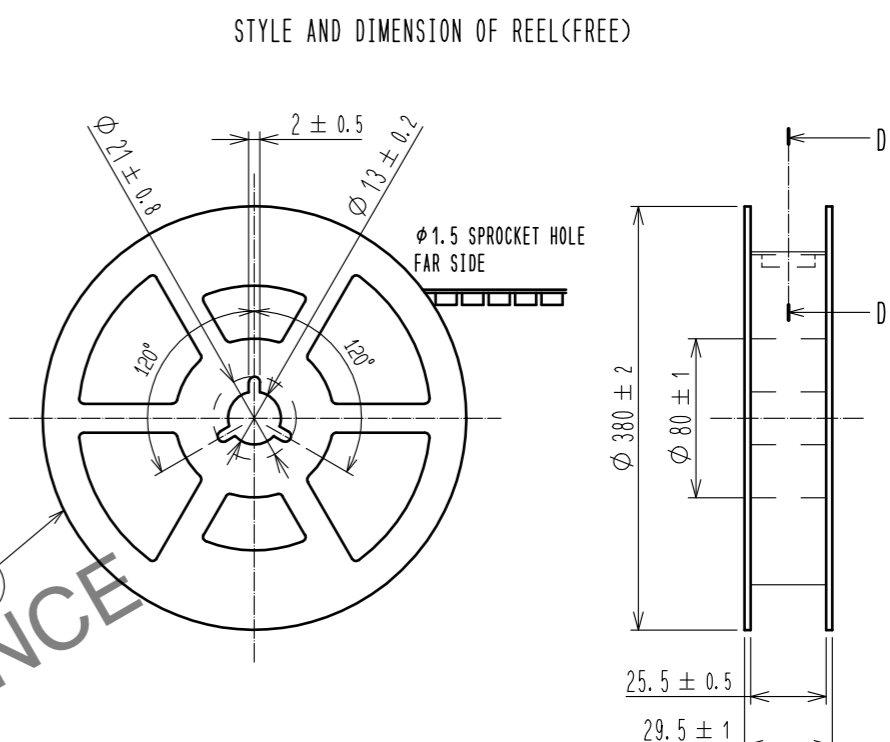
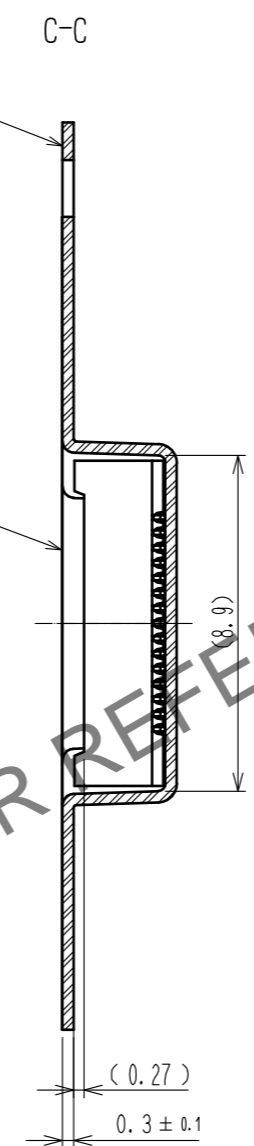
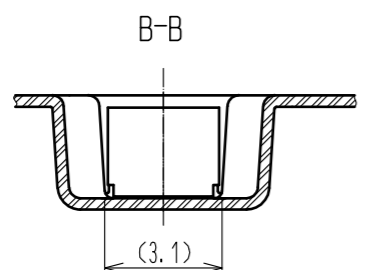
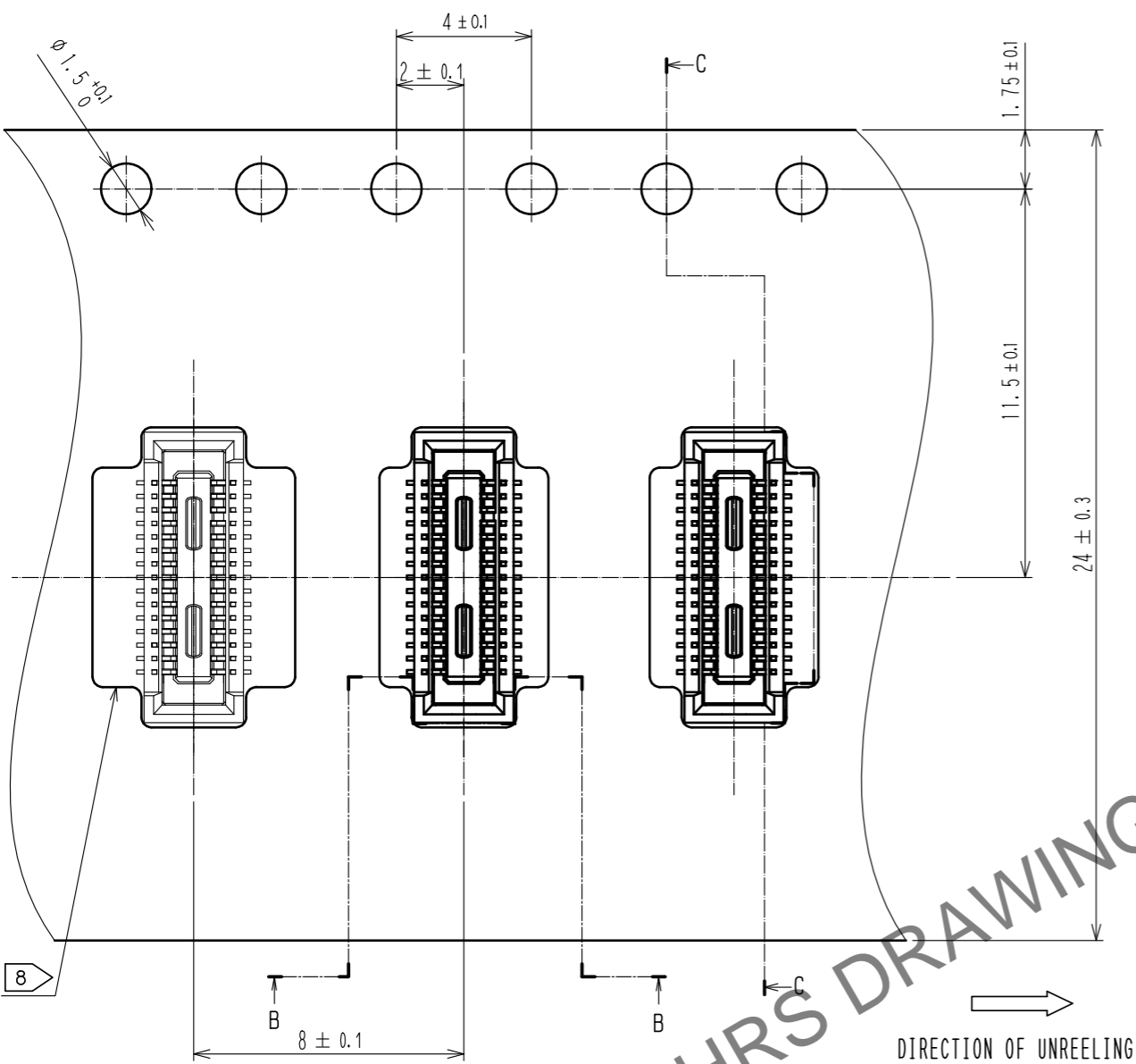

- NOTES
4. PER REEL 3000 CONNECTORS.
 5. THE DIMENSIONS IN PARENTHESES ARE FOR REFERENCE.
 6. REFER TO JIS C 0806, IEC 60286-3
(PACKING OF COMPONENTS FOR AUTOMATIC HANDLING)
 7. AFTER PACKAGING, ROLL 2 METERS OF THE REINFORCEMENT COLLAR TO OUTER CIRCUMFERENCE OF TAPE AND REEL POCKET. AND TAPE DOWN AT THE END THE COLLAR.
 8. ONE OF SEVERAL IS DIFFERENT IN FROM OF THE EMBOSSED CARRIER TAPE TO AVOID BEING STUCK IN.

HRS	DRAWING NO.	EDC-386697-51-00	
	PART NO.	DF40TC(2.5)-30DS-0.4V(51)	
	CODE NO.	CL0684-4266-0-51	2/2

HRS DRAWING FOR REFERENCE