

Mar.1.2026 Copyright 2026 HIROSE ELECTRIC CO., LTD. All Rights Reserved.
In case of consideration for using Automotive equipment / device which demand high reliability, kindly contact our sales window correspondents.

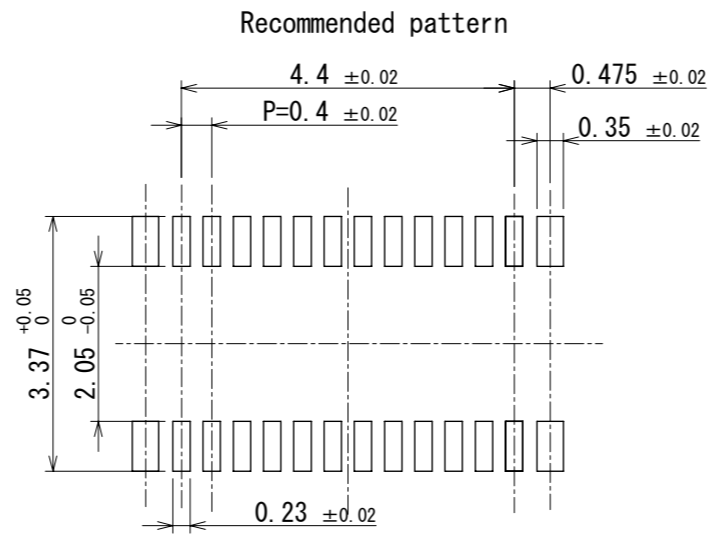

Recommended metal mask thickness : 120μm
Recommended metal mask opening ratio : 80% for lead pad

5 Recommended reflow temperature profile for lead-free solder.

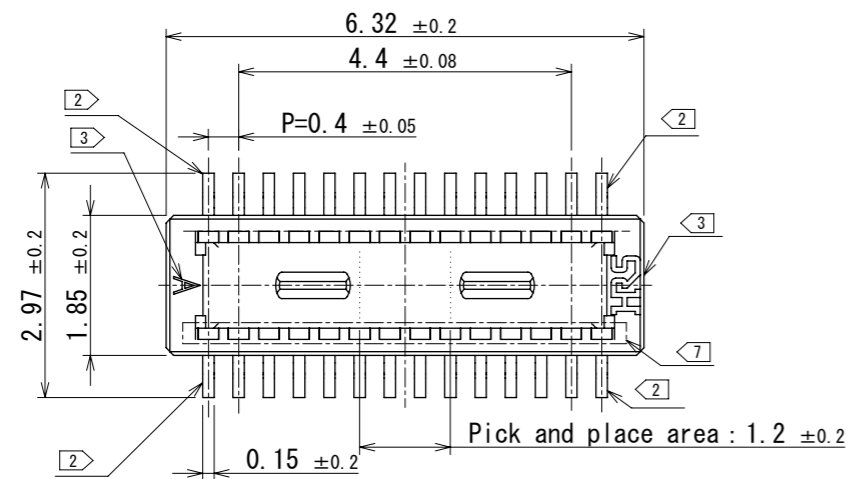
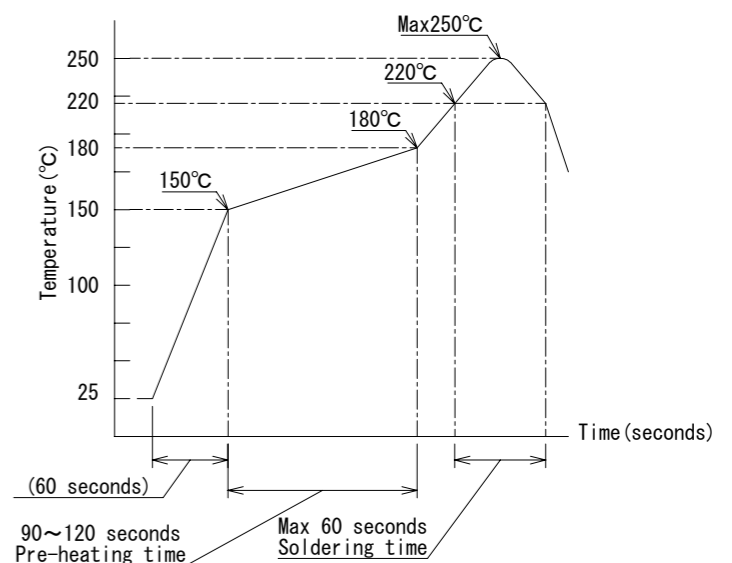

Reflow method : IR reflow
Number of reflow cycles : 2 cycles max.
1) Reflow time
Duration above 220°C, 60 sec max.
(peak temperature : 250°C max)
2) Pre-heat time
Pre-heat temperature (min) : 150°C
Pre-heat temperature (max) : 180°C
Pre-heat time : 90~120 sec.

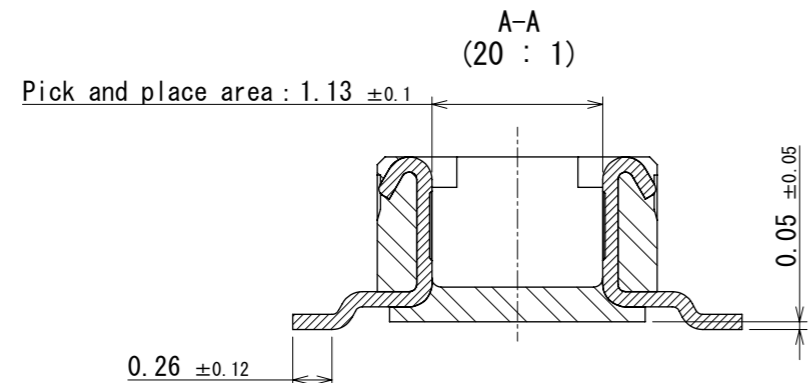
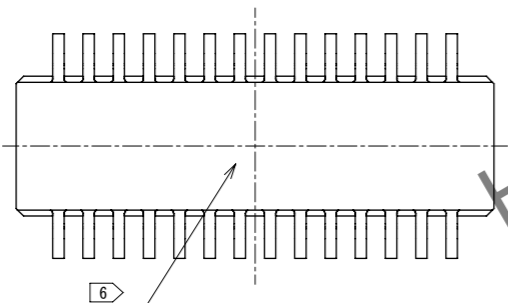
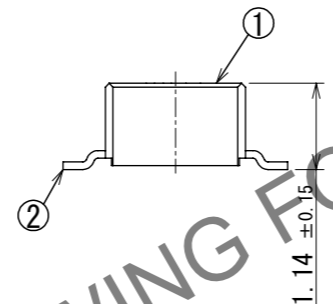
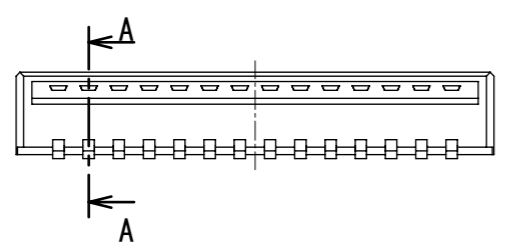

HRS DRAWING FOR REFERENCE

- Note
1. All lead co-planarity will be 0.1mm max.
 2. Each one contact at 4 corners is reinforced fittings.
 3. HRS mark and cavity No. are indicated at approximate location.
 4. Plating specifications
Contact area : Gold 0.05μm min
SMT lead : Gold 0.05μm min
Under plating : Nickel 1μm min
(Surface : Sealing)
 5. This temperature profile is based on the suggested metal mask and footprint. Please contact us if using different settings from our recommendation.
 6. Gate trace may appear in indicated area.
 7. The resin may overlap the top surface of the metal but will not affect the contact reliability.

2	Copper alloy	4	6	PS	Clear. Reinforcement collar			
1	LCP	Black	5	PS	Black. Plastic reel			
			4	Polyster	Clear. Cover tape			
			3	PS	Clear. Embossed carrier tape			
NO.	MATERIAL	FINISH	REMARKS	NO.	MATERIAL	FINISH	REMARKS	
UNITS	mm	SCALE	COUNT	DESCRIPTION OF REVISIONS		DESIGNED	CHECKED	DATE
		10:1	3	DIS-H-00021705		NK. TOYOSU	YK. SATAKE	2024. 10. 31
APPROVED : TY. OOI		2024. 01. 15		DRAWING NO.		EDC-404943-51-00		
CHECKED : RT. SHIMIZU		2024. 01. 15		PART NO.		DF40TC-24DP-0. 4V (51)		
DESIGNED : YK. SATAKE		2024. 01. 15		CODE NO.		CL0684-4308-0-51		
DRAWN : NK. TOYOSU		2024. 01. 15						

Mar.1.2026 Copyright 2026 HIROSE ELECTRIC CO., LTD. All Rights Reserved.
 In case of consideration for using Automotive equipment / device which demand high reliability, kindly contact our sales window correspondents.

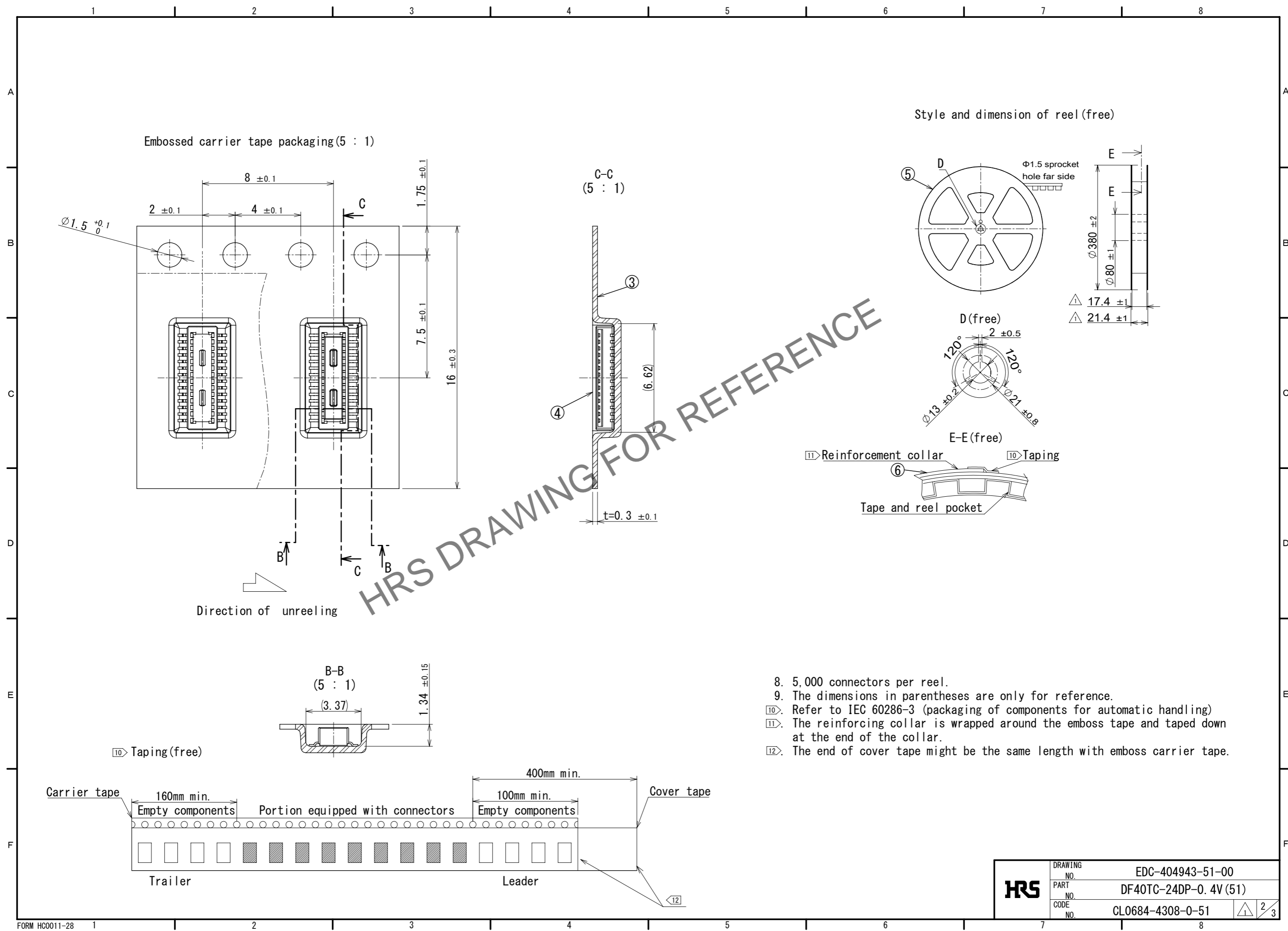

HRS DRAWING FOR REFERENCE

- 8. 5,000 connectors per reel.
- 9. The dimensions in parentheses are only for reference.
- ⑩. Refer to IEC 60286-3 (packaging of components for automatic handling)
- ⑪. The reinforcing collar is wrapped around the emboss tape and taped down at the end of the collar.
- ⑫. The end of cover tape might be the same length with emboss carrier tape.

HRS	DRAWING NO.	EDC-404943-51-00	2/3
	PART NO.	DF40TC-24DP-0.4V (51)	
	CODE NO.	CL0684-4308-0-51	
	NO.		

Mar.1.2026 Copyright 2026 HIROSE ELECTRIC CO., LTD. All Rights Reserved.
In case of consideration for using Automotive equipment / device which demand high reliability, kindly contact our sales window correspondents.

13. Please refer to the product guideline ETAD-H1015 for detail of connector handling.

The position between the connector and PAD

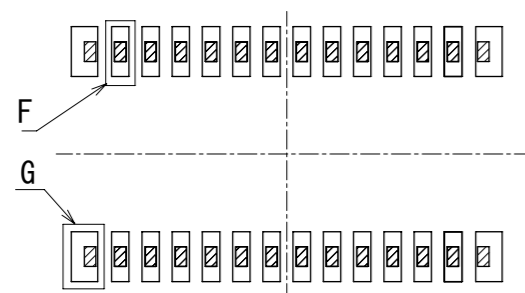

Connector lead on PAD layout
 PAD layout

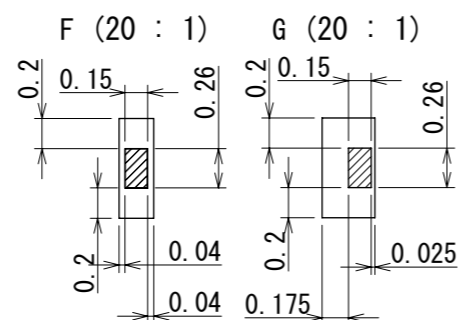

Mating method

Please mate the connector by hand.

Mating procedure

- Find the alignment area to the connector in the appropriate mating position. This connector has an alignment chamber (guidance ribs) on receptacle side and "r" on plug side, so that the connector will be self-aligned. When the connector comes to the appropriate position, the connector goes into the aligned position. When aligned, it can be felt by hand.

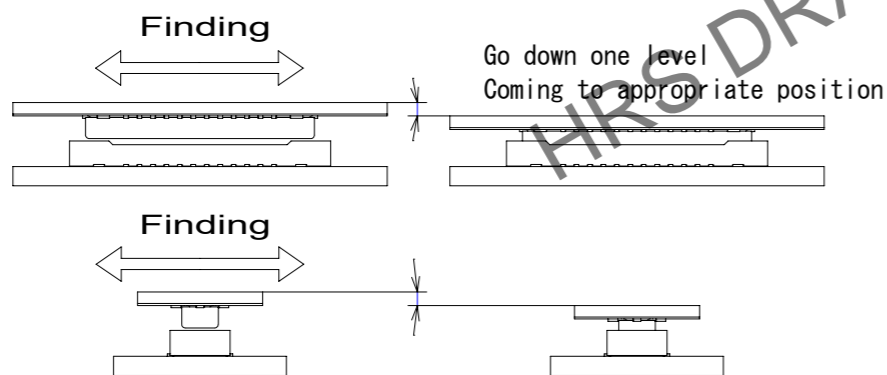

- When guiding, the connectors are aligned parallel to each other, with longitudinal and lateral movements restricted. Mate them properly by applying force in this condition.

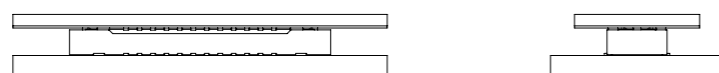

- Make sure the connectors are mated correctly. If one side is floating or the connectors are mated in one direction, un-mate them once, and then mate them again, following the procedures above from the beginning.

Un-mating method

Please un-mate the connector by hand

- Un-mate the connectors parallel to each other. However, if the connectors have high pin counts or thinner fpc and stiffener, it becomes more difficult to do so.

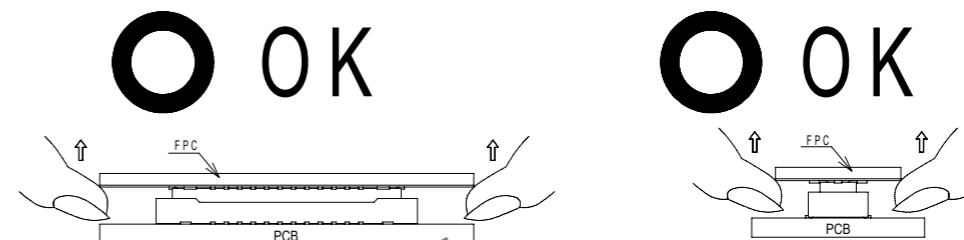

- If the connector cannot be un-mated parallel it can be removed diagonally from the pitch direction. Be careful to do so since this action applies stress on the contact.



- If the fpc is not rigid, the connector can be broken. Please check the action of the fpc to be used repeatedly at the time of trial production. Be careful to un-mate them from the pitch direction, pulling it from the corner can also risk to putting stress on contacts.

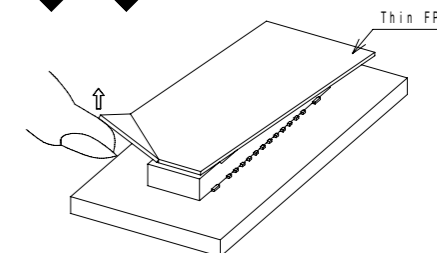
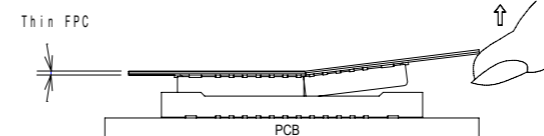

HRS	DRAWING NO.	EDC-404943-51-00	3/3
	PART NO.	DF40TC-24DP-0.4V(51)	
	CODE NO.	CL0684-4308-0-51	