

Nov.1.2024 Copyright 2024 HIROSE ELECTRIC CO., LTD. All Rights Reserved.
 In case of consideration for using Automotive equipment / device which demand high reliability, kindly contact our sales window correspondents.

ELV, RoHS COMPLIANT

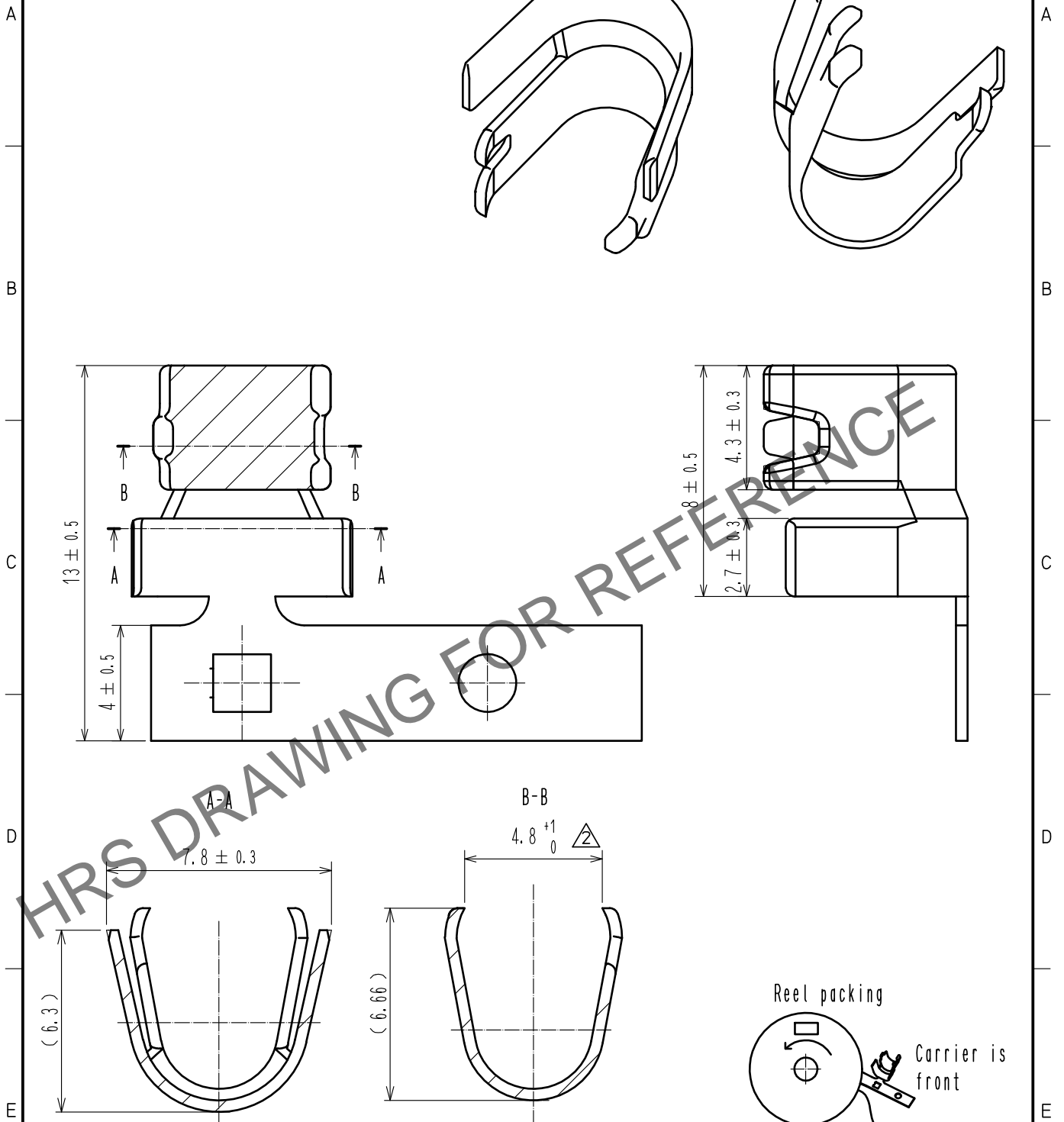

Note 1. 1400PCS/RL . A box of 4RL.
 2. Assembly procedure refer to ETAD-T0574-00

1	BRASS	SURFACE:TIN PLATING 1μm MIN UNDER PLATING:NICKEL 0.5μm MIN	2	-	-		
NO.	MATERIAL	FINISH . REMARKS	NO.	MATERIAL	FINISH . REMARKS		
UNITS mm		SCALE 5 : 1	COUNT 1	DESCRIPTION OF REVISIONS DIS-T-00003652	DESIGNED KO. NAKAMURA	CHECKED AH. EDASHIGE	DATE 18. 08. 02
HRS HIROSE ELECTRIC CO., LTD.	APPROVED	:HK. UMEHARA	16. 11. 28	DRAWING NO.	EDC-368757-00-00		
	CHECKED	:HK. UMEHARA	16. 11. 28	PART NO.	HVH-280-4. 2CF		
	DESIGNED	:KO. NAKAMURA	16. 11. 28	CODE NO.	CL778-0503-0-00		1/1
	DRAWN	:KO. NAKAMURA	16. 11. 28				