

# 1mm Pitch Connectors for Vertical Connection

## FX5 Series

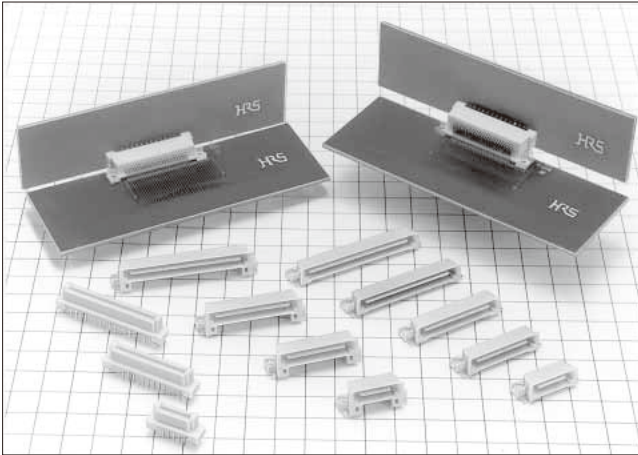

### Connecting Height: Low profile

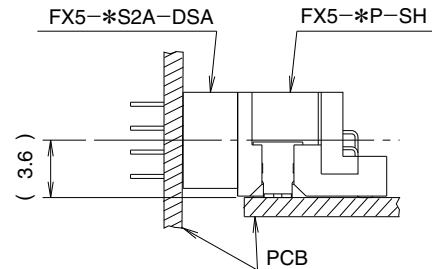

Fig.1

## ■ Features

### 1. Header Side : 2 Types Available

Two header types are available, low and high profiles. Combined with various contact positions, the FX5 is versatile to work in many application. (See Fig.1 and 2)

### 2. Two-step, Sequential Mating

The mating sequence features a 2-step, "first mate-last break" condition that helps to protect the circuit.

### 3. Mating Guide

A guide rib is provided along with a self-alignment range of  $\pm 1$ mm to allow for easy mating operations.

### 4. SMT Coplanarity

The coplanarity of SMT soldered area has a high accuracy of 0.1mm.

### 5. Miniaturization

The FX5 uses about 30% less mounting area on the board compared with a 1.27mm pitch connector.

### Connecting Height: High profile

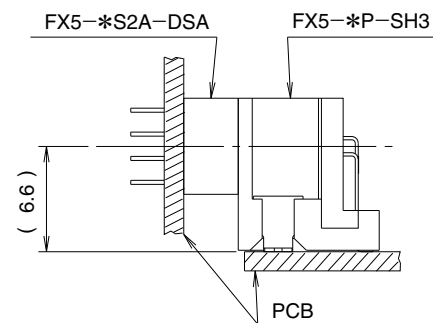

Fig.2

## Product Specifications

Ratings	Current rating 0.5A	Operating Temperature Range -55°C to +85°C (Note 1)	Storage Temperature Range -10°C to +60°C (Note 2)
	Voltage rating 100V AC	Operating Humidity Range 40% to 80%	Storage Humidity Range 40% to 70%

Items	Specifications	Conditions
1. Insulation Resistance	100M ohms min.	250V DC
2. Withstanding voltage	No flashover or insulation breakdown.	300V AC/1 minute
3. Contact Resistance	50m ohms max.	100mA
4. Vibration Resistance	No electrical discontinuity of 1μs or more	Frequency: 10 to 55 Hz, single amplitude of 0.75 mm, 2 hours in each of the 3 directions.
5. Moisture Resistance	Contact resistance: 60m ohms max. Insulation resistance: 100M ohms min.	96 hours at temperature of 40°C and humidity of 90% to 95%
6. Temperature Cycle	Contact resistance: 60m ohms max. Insulation resistance: 100M ohms min.	(-55°C: 30 minutes, 15 to 35°C: 2 to 3 minutes 85°C: 30 minutes, 15 to 35°C: 2 to 3minutes) 5 cycles
7. Mating Cycles	Contact resistance: 60m ohms max.	500 cycles
8. Resistance to Soldering heat	No deformation of components affecting performance.	SMT Reflow: At the recommended temperature profile Manual soldering: 360°C for 5 seconds
		DIP Solder Bath: 260°C for 10 seconds Manual soldering: 360°C for 5 seconds

Note 1: Includes temperature rise caused by current flow.

Note 2: The term "storage" refers to products stored for a long time prior to use. Operating temperature and humidity range includes a non-conducting state of installed connectors in storage, shipment, or during transportation.

## Material

Part	Material	Finish	Remarks
Insulator	Polyamide	Beige	UL94V-0
Header Contact	Brass	Contact area : Gold plated	———
Receptacle Contact	Phosphor bronze	Lead area : Tin plated	———

Note : The black dots on the insulator will not affect performance

## Product Number Structure

### Header

**FX5** - **\*** **P** - **SH** **3**

①                    ②   ③                    ④   ⑤

① Series Name : FX5	⑤ Connector Height
② Number of Contacts : 20, 40, 52, 56, 68, 80	Blank : 6.5mm
③ Connector Type P: Header	3 : 9.5mm
④ Contact type SH : Right angle SMT type	

Note: The 56 contact header is for SH 3 type only.

### Receptacle

**FX5** - **\*** **S** **2** **A** - **DSA** **L**

①                    ②   ③   ④   ⑤                    ⑥   ⑦

① Series Name : FX5	⑥ Contact type
② Number of Contacts : 20, 40, 52, 56, 68, 80	DSA : Straight through hole type
③ Connector Type S: Receptacle	⑦ Board prefixed pin
④ Contact Sequence 2 : 2 Stages Sequence	Blank : Without board prefixed pin L : With board Prefixed pin
⑤ Serial No. : A	

## Header

### Low profile



### High profile

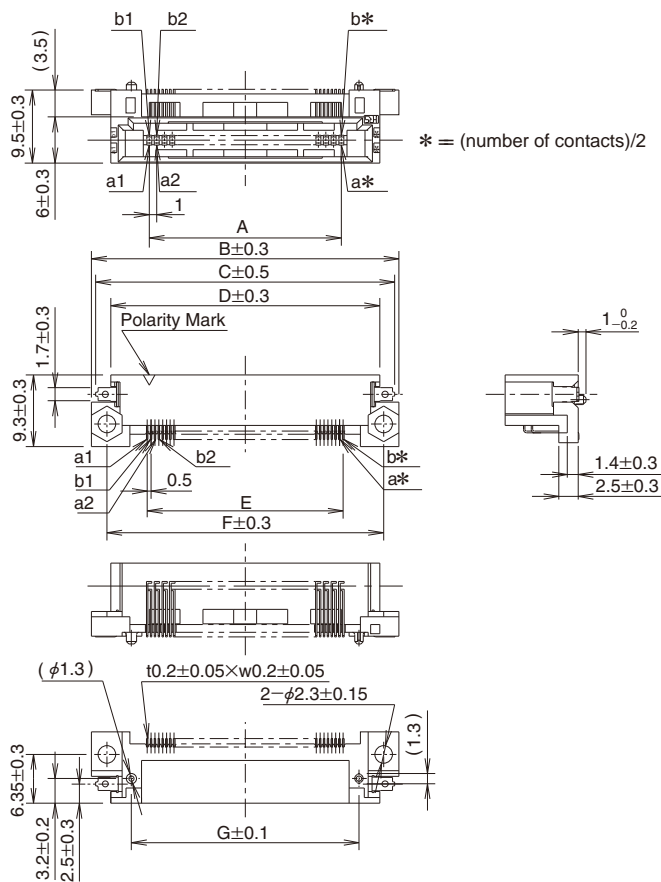
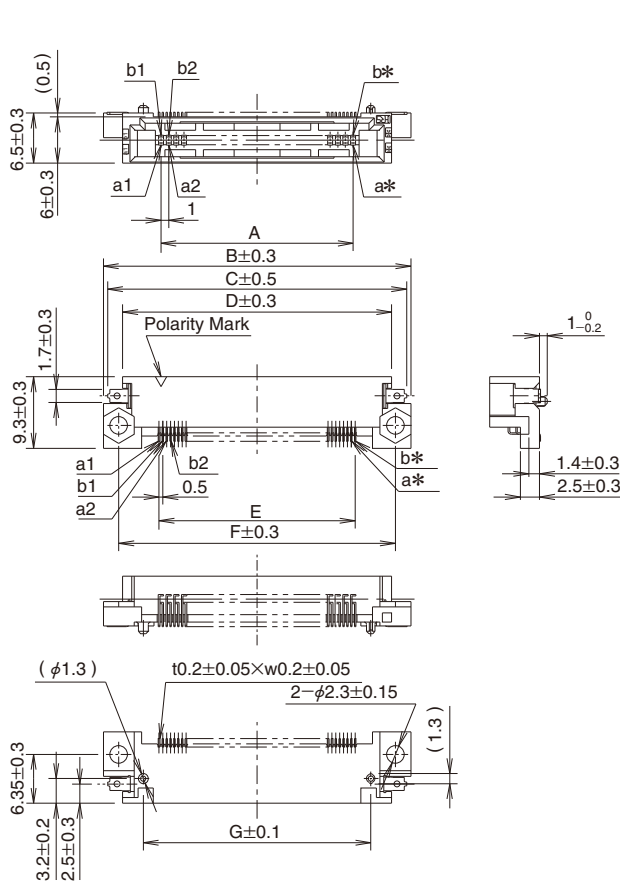

Unit: mm

Part No.	HRS No.	No. of contacts	A	B	C	D	E	F	G	RoHS
FX5-20P-SH(71)	575-0001-7 71	20	9	24	22.9	19	9.5	20	13.6	Yes
FX5-20P-SH3(71)	575-0041-1 71									
FX5-40P-SH(71)	575-0005-8 71	40	19	34	32.9	29	19.5	30	23.6	
FX5-40P-SH3(71)	575-0045-2 71									
FX5-52P-SH(71)	575-0006-0 71	52	25	40	38.9	35	25.5	36	29.6	
FX5-52P-SH3(71)	575-0046-5 71									
FX5-56P-SH3(71)	575-1001-2 71	56	27	42	40.9	37	27.5	38	31.6	
FX5-68P-SH(71)	575-0008-6 71	68	33	48	46.9	43	33.5	44	37.6	
FX5-68P-SH3(71)	575-0048-0 71									
FX5-80P-SH(71)	575-0009-9 71	80	39	54	52.9	49	39.5	50	43.6	
FX5-80P-SH3(71)	575-0049-3 71									

## Receptacle

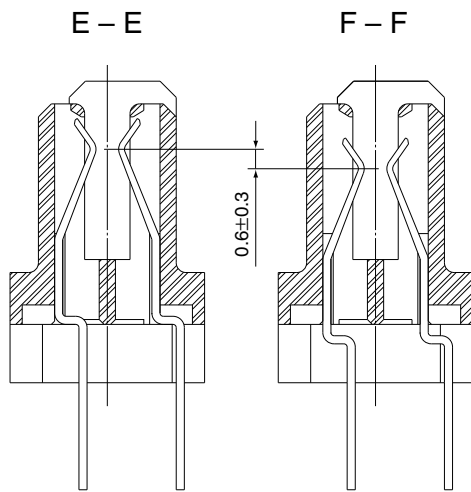
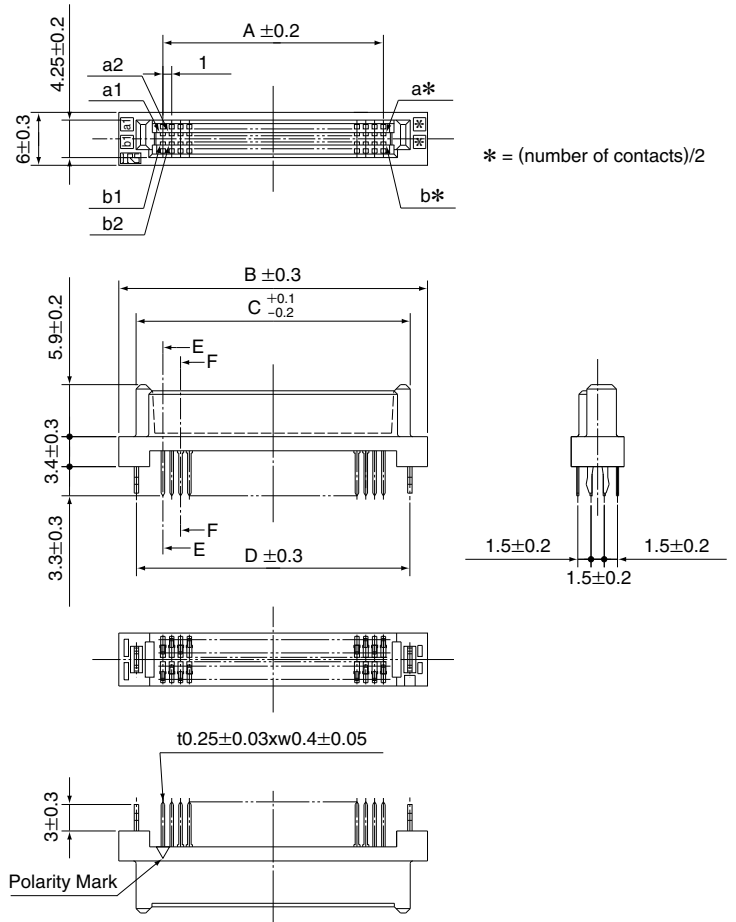
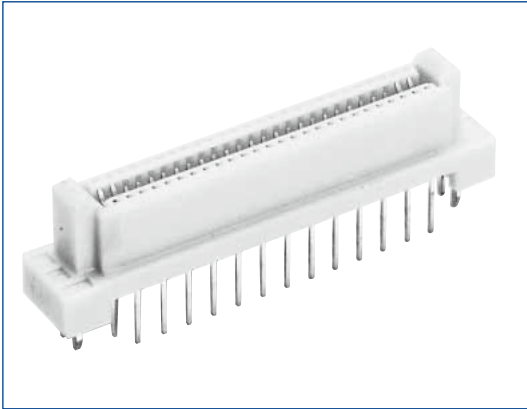

Unit: mm

Part No.	HRS No.	No. of contacts	A	B	C	D	Order of Contact Sequence(Contact No.)		RoHS
							1	2	
FX5-20S2A-DSA(71)	575-0101-1 71	20	9	19	15.08	—	a1,a2,a9,a10	a3 to a8	Yes
FX5-20S2A-DSAL(71)	575-0121-9 71					15	b1,b2,b9,b10	b3 to b8	
FX5-40S2A-DSA(71)	575-0105-2 71	40	19	29	25.08	—	a1,a2,a19,a20	a3 to a18	
FX5-40S2A-DSAL(71)	575-0125-0 71					25	b1,b2,b19,b20	b3 to b18	
FX5-52S2A-DSA(71)	575-0106-5 71	52	25	35	31.08	—	a1,a2,a25,a26	a3 to a24	
FX5-52S2A-DSAL(71)	575-0126-2 71					31	b1,b2,b25,b26	b3 to b24	
FX5-56S2A-DSA(71)	575-0107-8 71	56	27	37	33.08	—	a1,a2,a27,a28	a3 to a26	
FX5-56S2A-DSAL(71)	575-0127-5 71					33	b1,b2,b27,b28	b3 to b26	
FX5-68S2A-DSA(71)	575-0108-0 71	68	33	43	39.08	—	a1,a2,a33,a34	a3 to a32	
FX5-68S2A-DSAL(71)	575-0128-8 71					39	b1,b2,b33,b34	b3 to b32	
FX5-80S2A-DSA(71)	575-0109-3 71	80	39	49	45.08	—	a1,a2,a39,a40	a3 to a38	
FX5-80S2A-DSAL(71)	575-0129-0 71					45	b1,b2,b39,b40	b3 to b38	

### PCB mounting pattern

#### Header

##### FX5-\*SH, FX5-\*SH3

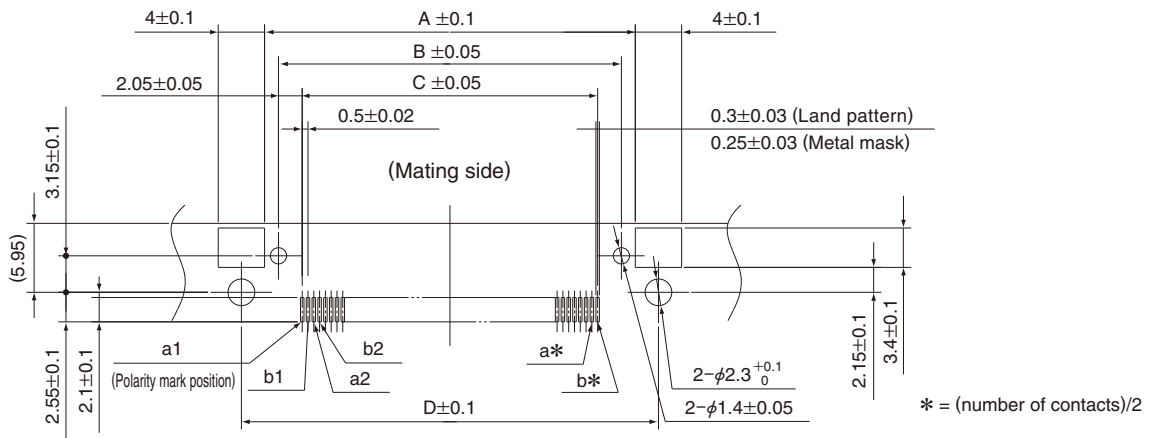

#### Receptacle

##### FX5-\*S2A-DSA

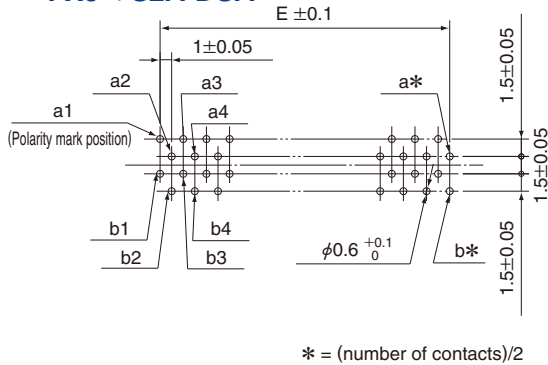

##### FX5-\*S2A-DSAL

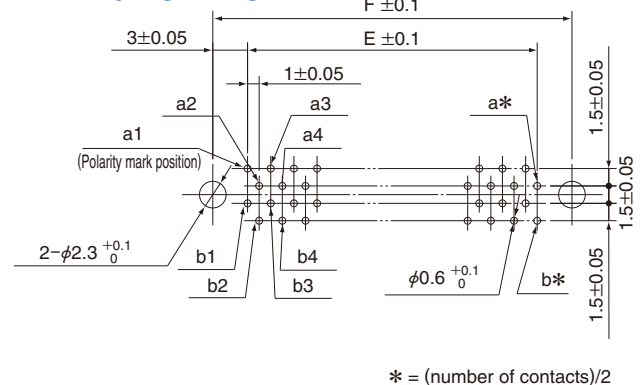

Unit: mm

No. of contacts	A	B	C	D	E	F
20	16	13.6	9.5	20	9	15
40	26	23.6	19.5	30	19	25
52	32	29.6	25.5	36	25	31
56	34	31.6	27.5	38	27	33
68	40	37.6	33.5	44	33	39
80	46	43.6	39.5	50	39	45

Note: If the connector uses a mounting area over the recommended size, it could cause defects in mounting and soldering. For best results, mount the connector using the recommended PCB mounting pattern.

### Recommended Temperature Profile

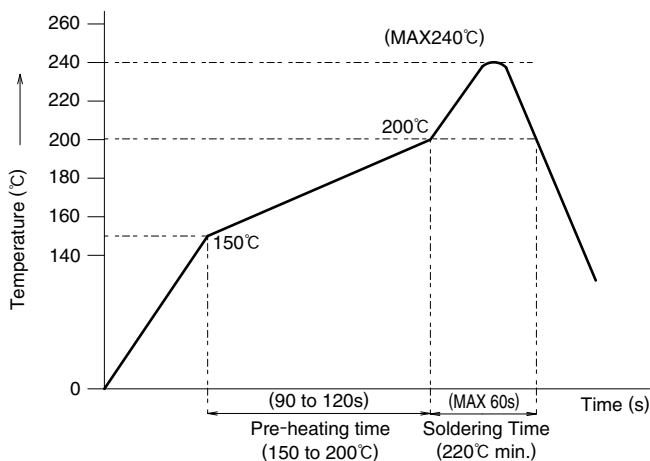

#### HRS test conditions

Test board Glass epoxy 110mm×40mm×1.6mm thick

Solder method : Reflow

Solder composition : Paste, 96.5%Sn/3%Ag/0.5%Cu

Metal mask : 0.15mm thick

Reflow cycles : 1 cycles

The temperature profile is based on the above conditions.

In individual applications the actual temperature may vary, depending on solder paste type, volume/thickness and board size/thickness. Consult your solder paste and equipment manufacturer for specific recommendations.

## ◆ Cleaning Conditions

### 1. Organic Solvent Cleaning

Solvent	Cold Cleaning	
IPA (Isopropyl alcohol)	Yes	Yes

\*Methylene chloride is not suitable for this product.

### 2. Liquid Cleaning

2. When cleaning with liquid detergents (e.g. terpene, alkali saponifiers), consult the manufacturer's specifications and make sure that the cleaner is suitable for use with the metal and resin components of this connector. Also, do not leave the connector outside where it moisture could infiltrate the product.

### 3. Cautions for Cleaning

3. If any organic solvent or other liquid cleaner or flux remains in the connector, it can cause electrical performance degradation. Please make sure that the connector is completely free of any cleaner or flux before use.

## ◆ Connector Precautions

### 1. Tolerance Clearance on Mating Side

The effective clearance of this product is 1.6mm. Please make sure that your design accounts for 1mm mating clearance between the header and receptacle.

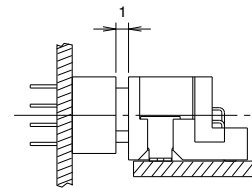

### 2. Header Connector Height

Because the SMT height specification for the header does not account for the thickness of the solder paste, please remember to account for the extra height in the total stacking height.

#### Mating Height: Low profile

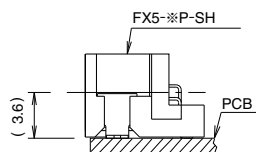

#### Mating Height: High profile

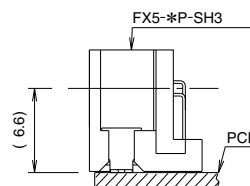

### 3. Screw Fastening Torque (SMT Type)

When the screw is fastened, please use the M2 screw. The recommended fastening torque is 0.15(N.m) max.

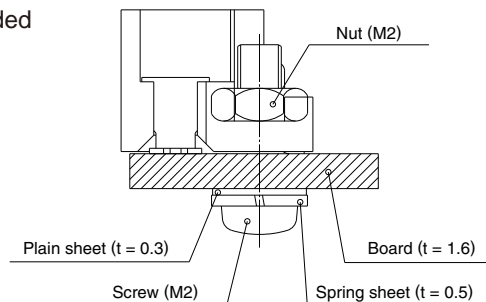

### 4. Prefixed Process to Board (Through hole Type)

If the prefixed process is required for board mounting, please use the prefixed pin type. (Applicable Thickness  $t = 1.6 \pm 0.1$ )

**Note:**

When the connector is mounted on the board, the dip post is guided into the through-hole first. To prevent dip post damage, make sure that the connector is parallel to the board during this process.

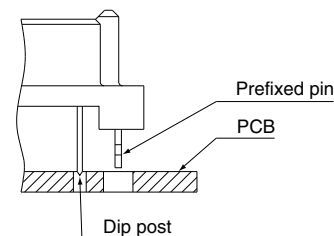

### 5. Plug and Play

Please consult your Hirose representative if you will be mating/unmating the connector while the circuit is energized.

### 6. Others

- Excessive force during mating/unmating will damage the connector.
- Avoid using the mated connectors as a means of holding the PCB together.  
The PCBs need to be secured together with screws, spacers or other means which do not rely on the connectors as the primary support mechanism.
- The resin color of the product may vary slightly with different production lots.  
This does not effect the performance.

**USA:**

**HIROSE ELECTRIC (U.S.A.), INC. HEADQUARTERS**  
 2688 Westhills Court, Simi Valley, CA 93065-6235  
 Phone : +1-805-522-7958  
 Fax : +1-805-522-3217  
<http://www.hirose.com/us/>

**USA:**

**HIROSE ELECTRIC (U.S.A.), INC. SAN JOSE OFFICE**  
 3255 Scott Boulevard, Building 7, Suite 101  
 Santa Clara, CA 95054  
 Phone : +1-408-253-9640  
 Fax : +1-408-253-9641  
<http://www.hirose.com/us/>

**USA:**

**HIROSE ELECTRIC (U.S.A.), INC. CHICAGO OFFICE**  
 580 Waters Edge Lane, Suite 205 Lombard IL  
 60148  
 Phone : +1-630-282-6701  
 Mail : [inquiries@hirose.com](mailto:inquiries@hirose.com)  
<http://www.hirose.com/us/>

**USA:**

**HIROSE ELECTRIC (U.S.A.), INC. DETROIT OFFICE (AUTOMOTIVE)**  
 17197 N. Laurel Park Drive, Suite 253, Livonia,  
 MI 48152  
 Phone : +1-734-542-9963  
 Fax : +1-734-542-9964  
<http://www.hirose.com/us/>

**THE NETHERLANDS:**

**HIROSE ELECTRIC EUROPE B.V.**  
 Hogehillweg #8 1101 CC Amsterdam Z-0  
 Phone : +31-20-6557460  
 Fax : +31-20-6557469  
<http://www.hirose.com/eu/>

**GERMANY:**

**HIROSE ELECTRIC EUROPE B.V. GERMAN BRANCH**  
 Herzog-Carl-Strasse 4 D-73760 Ostfildern  
 (Scharnhäuser Park)  
 Phone : +49-711-4560-02-1  
 Fax : +49-711-4560-02-299  
<http://www.hirose.com/eu/>

**GERMANY:**

**HIROSE ELECTRIC EUROPE B.V. NUERNBERG OFFICE**  
 Muggenhofer Str. 136 90429 Nuernberg  
 Phone : +49-911 32 68 89 63  
 Fax : +49-911 32 68 89 69  
<http://www.hirose.com/eu/>

**GERMANY:**

**HIROSE ELECTRIC EUROPE B.V. HANOVER OFFICE**  
 Bayernstr. 3, Haus C 30855 Langenhagen, Germany  
 Phone : +49-511 97 82 61 30  
 Fax : +49-511 97 82 61 35  
<http://www.hirose.com/eu/>

**FRANCE:**

**HIROSE ELECTRIC EUROPE B.V. PARIS OFFICE**  
 Regus La Garenne Colombes, Place de La Belgique,  
 71 Boulevard National La Garenne Colombes, 92250, France  
 Phone : +33 (0) 1 7082 3170  
 Fax : +33 (1) 7082 3101  
<http://www.hirose.com/eu/>

**UNITED KINGDOM:**

**HIROSE ELECTRIC EUROPE BV (UK BRANCH)**  
 4 Newton Court, Kelvin Drive, Knowlhill,  
 Milton Keynes, MK5 8NH  
 Phone : +44-1908 202050  
 Fax : +44-1908 202058  
<http://www.hirose.com/eu/>

**CHINA:**

**HIROSE ELECTRIC (SHANGHAI) CO., LTD.**  
 1601, Henderson Metropolitan, NO.300, East Nanjing  
 Road, Huangpu District, Shanghai, China 200001  
 Phone : +86-21-6391-3355  
 Fax : +86-21-6391-3335  
<http://www.hirose.com/cn/>

**CHINA:**

**HIROSE ELECTRIC (SHANGHAI) CO.,LTD. BEIJING BRANCH**  
 A1001, Ocean International Center, Building 56# East 4th  
 Ring Middle Road, ChaoYang District, Beijing, 100025  
 Phone : +86-10-5165-9332  
 Fax : +86-10-5908-1381  
<http://www.hirose.com/cn/>

**CHINA:**

**HIROSE ELECTRIC TECHNOLOGIES (SHENZHEN) CO., LTD.**  
 Room 09-13, 19/F, Office Tower Shun Hing Square, Di Wang Commercial Centre,  
 5002 Shen Nan Dong Road, Shenzhen City, Guangdong Province, 518008  
 Phone : +86-755-8207-0851  
 Fax : +86-755-8207-0873  
<http://www.hirose.com/cn/>

**HONG KONG:**

**HIROSE ELECTRIC HONGKONG TRADING CO., LTD.**  
 Room 1001, West Wing, Tsim Sha Tsui Centre, 66  
 Mody Road, Tsim Sha Tsui East, Kowloon, Hong Kong  
 Phone : +852-2803-5338  
 Fax : +852-2591-6560  
<http://www.hirose.com/hk/>

**TAIWAN:**

**HIROSE ELECTRIC TAIWAN CO., LTD.**  
 103 8F, No.87, Zhengzhou Rd., Taipei  
 Phone : +886-2-2555-7377  
 Fax : +886-2-2555-7350  
<http://www.hirose.com/tw/>

**KOREA:**

**HIROSE KOREA CO., LTD.**  
 250, Huimanggongwon-ro, Siheung-si,  
 Gyeonggi-do, Korea, 429-849  
 Phone : +82-31-496-7000,7124  
 Fax : +82-31-496-7100  
<http://www.hirose.co.kr/>

**SINGAPORE:**

**HIROSE ELECTRIC SINGAPORE PTE. LTD.**  
 10 Anson Road #26-16, International Plaza  
 079903, Singapore  
 Phone : +65-6324-6113  
 Fax : +65-6324-6123  
<http://www.hirose.com/sg/>

**INDIA:**

**HIROSE ELECTRIC SINGAPORE PTE. LTD. DELHI LIAISON OFFICE**  
 Office NO.519, Regus-Green Boulevard, Level5, Tower C,  
 Sec62, Plot B-9A, Block B, Noida, 201301, Uttar Pradesh, India  
 Phone : +91-12-660-8018  
 Fax : +91-120-4804949  
<http://www.hirose.com/sg/>

**INDIA:**

**HIROSE ELECTRIC SINGAPORE PTE. LTD. BANGALORE LIAISON OFFICE**  
 Unit No-403, 4th Floor, No-84, Barton Centre, Mahatma  
 Gandhi (MG) Road, Bangalore 560 001, Karnataka, India  
 Phone : +91-80-4120 1907  
 Fax : +91-80-4120 9908  
<http://www.hirose.com/sg/>

**MALAYSIA:**

**HIROSE ELECTRIC SINGAPORE PTE. LTD.**  
 1-10-07, Suntech @ Penang Cybercity (1164),Lintang  
 Mayang Pasir 3,11950, Bayan Baru, Penang, Malaysia.  
 Phone : +604-619-2564  
 Fax : +604-619-2574  
<http://www.hirose.com/sg/>

**THAILAND:**

**HIROSE ELECTRIC SINGAPORE PTE. LTD. BANGKOK OFFICE (REPRESENTATIVE OFFICE)**  
 Unit 4703, 47th FL., 1 Empire Tower, South Sathorn  
 Road, Yannawa, Sathorn, Bangkok 10120 Thailand  
 Phone : +66-2-686-1255  
 Fax : +66-2-686-3433  
<http://www.hirose.com/sg/>



**HIROSE ELECTRIC CO.,LTD.**

2-6-3,Nakagawa Chuoh,Tsuzuki-Ku,Yokohama-Shi 224-8540,JAPAN  
 TEL: +81-45-620-3526 Fax: +81-45-591-3726  
<http://www.hirose.com>  
<http://www.hirose-connectors.com>