

Sep.1.2024 Copyright 2024 HIROSE ELECTRIC CO., LTD. All Rights Reserved.
In case of consideration for using Automotive equipment / device which demand high reliability, kindly contact our sales window correspondents.

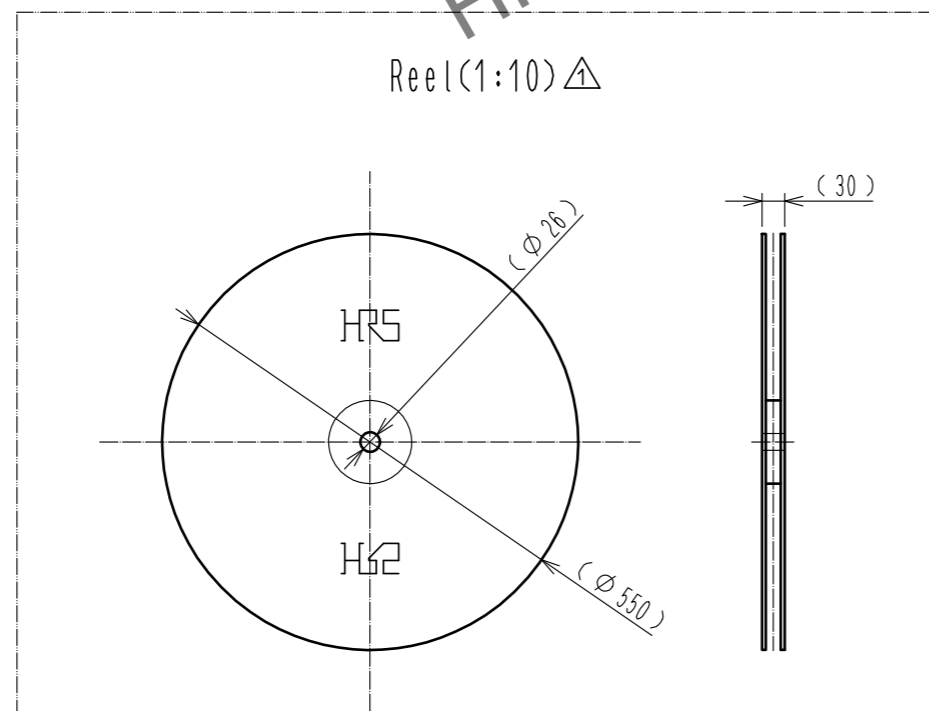
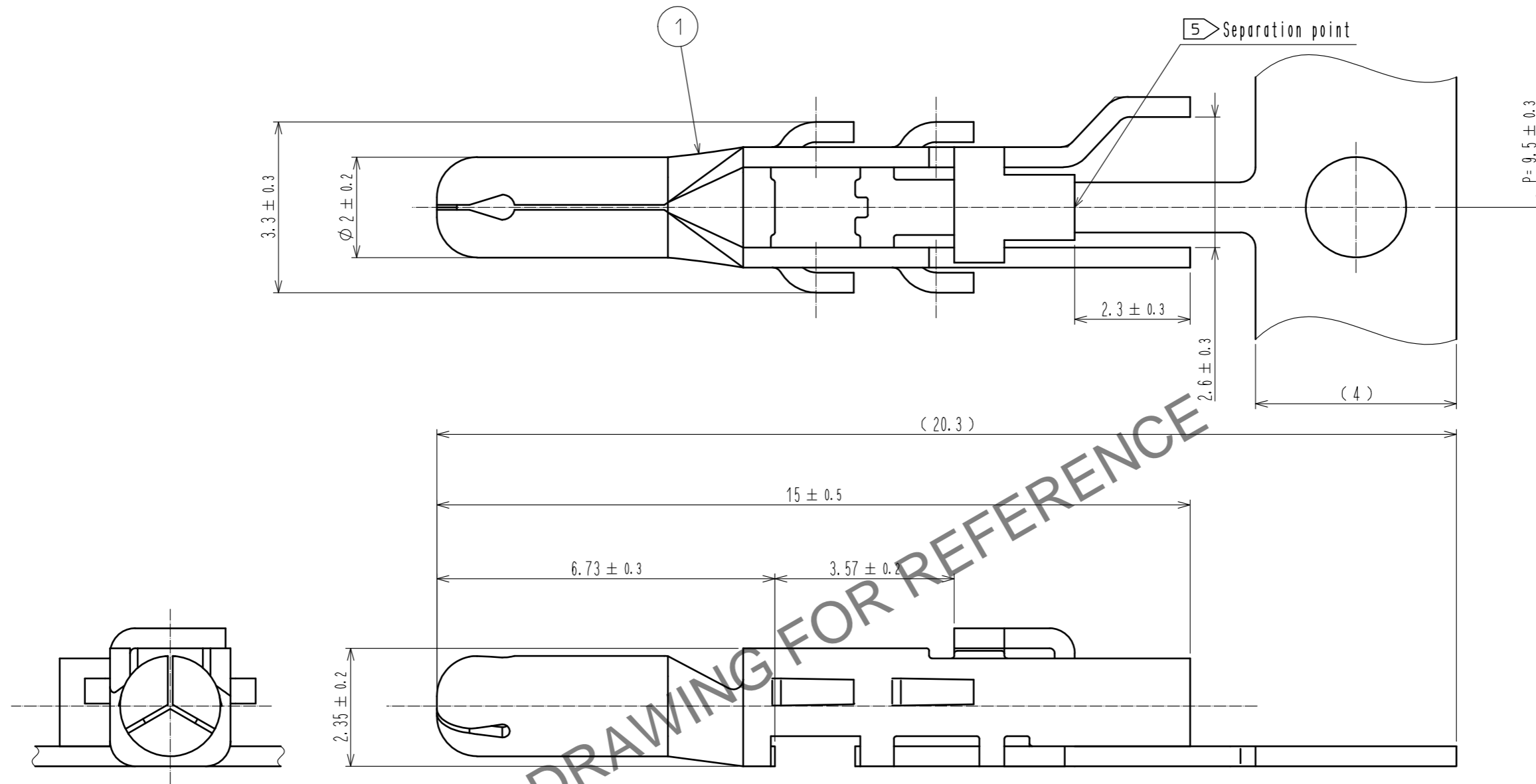

- Notes
- 1 The product is apply to the wire AWG#14 to 16(Wire jacket diameter: $\phi 2.6$ to 3.0)
 - 2 Per reel : 5,000 contacts.
 - 3 Surface plating : Tin plating $1\mu\text{m}$ min.
Under plating : Nickel plating $1\mu\text{m}$ min.
 - 4 The assembly of this product applies to the manual ETAD-C0454-00.
 - 5 Bend the terminal and carrier up and down in the axial direction of the pilot hole to separate them.
 - 6 This product is coated with lubricant on the surface.
Oil residues may be confirmed, but there is no problem with performance.
In addition, if dust etc. adhere, remove it with an air blow or the like before using.

1	Copper alloy	3					
NO.	MATERIAL	FINISH .	REMARKS	NO.	MATERIAL	FINISH .	REMARKS
UNITS		SCALE	COUNT	DESCRIPTION OF REVISIONS			DESIGNED
mm		10: 1	1	DIS-C-00009701			SH. KOYAMA
APPROVED : YH. YAMADA				20200128	DRAWING NO. EDC-390466-00-00		
CHECKED : HN. TANAKA				20200128	PART NO. BH12-P-213		
DESIGNED : SH. KOYAMA				20200128	CODE NO. CL0140-0016-0-00		
DRAWN : SH. KOYAMA				20200128	1/1		