

Sep.1.2024 Copyright 2024 HIROSE ELECTRIC CO., LTD. All Rights Reserved.
In case of consideration for using Automotive equipment / device which demand high reliability, kindly contact our sales window correspondents.

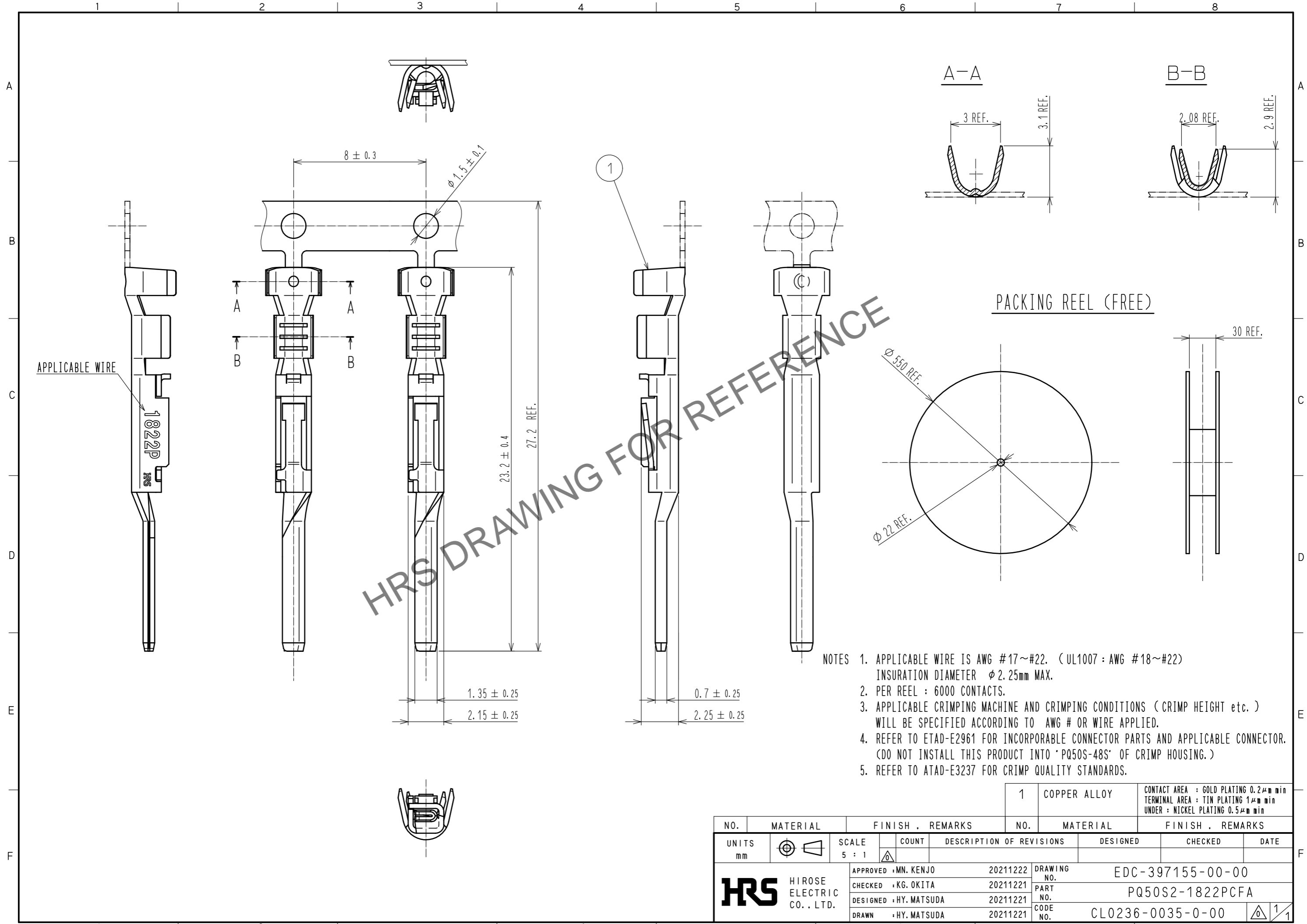

- NOTES
1. APPLICABLE WIRE IS AWG #17~#22. (UL1007 : AWG #18~#22)
INSURATION DIAMETER φ 2.25mm MAX.
 2. PER REEL : 6000 CONTACTS.
 3. APPLICABLE CRIMPING MACHINE AND CRIMPING CONDITIONS (CRIMP HEIGHT etc.)
WILL BE SPECIFIED ACCORDING TO AWG # OR WIRE APPLIED.
 4. REFER TO ETAD-E2961 FOR INCORPORABLE CONNECTOR PARTS AND APPLICABLE CONNECTOR.
(DO NOT INSTALL THIS PRODUCT INTO "PQ50S-48S" OF CRIMP HOUSING.)
 5. REFER TO ATAD-E3237 FOR CRIMP QUALITY STANDARDS.

PACKING REEL (FREE)

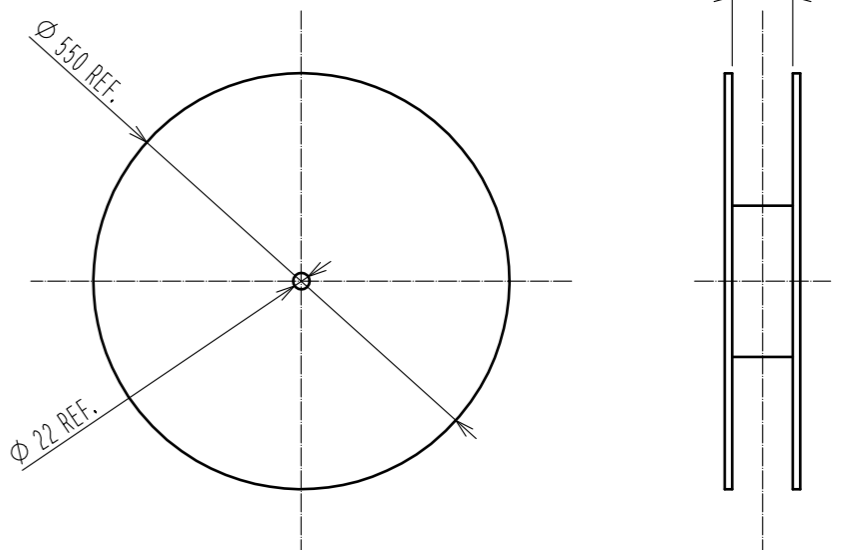

NO.		MATERIAL		FINISH . REMARKS		NO.		MATERIAL		FINISH . REMARKS	
		1		COPPER ALLOY				CONTACT AREA : GOLD PLATING 0.2μm min		TERMINAL AREA : TIN PLATING 1μm min	
								UNDER : NICKEL PLATING 0.5μm min			
UNITS		SCALE		COUNT		DESCRIPTION OF REVISIONS		DESIGNED		CHECKED	
mm		5 : 1		△						DATE	
HRS HIROSE ELECTRIC CO., LTD.		APPROVED : MN. KENJO		20211222		DRAWING NO.		EDC-397155-00-00			
		CHECKED : KG. OKITA		20211221		PART NO.		PQ50S2-1822PCFA			
		DESIGNED : HY. MATSUDA		20211221		CODE NO.		CL0236-0035-0-00			
		DRAWN : HY. MATSUDA		20211221							