

Oct.1.2024 Copyright 2024 HIROSE ELECTRIC CO., LTD. All Rights Reserved.  
In case of consideration for using Automotive equipment / device which demand high reliability, kindly contact our sales window correspondents.

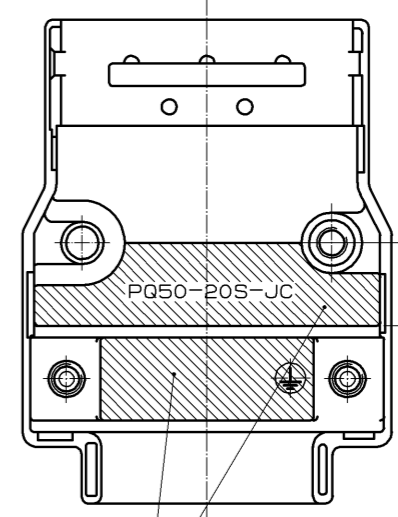

2 ATTACHMENT

JIS B 1188 : CROSS RECESSED NEED SCREWS WITH CAPTIVE WASHER  
M4×0.7×16

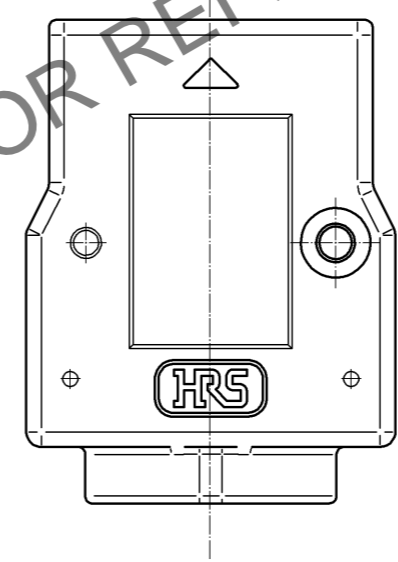
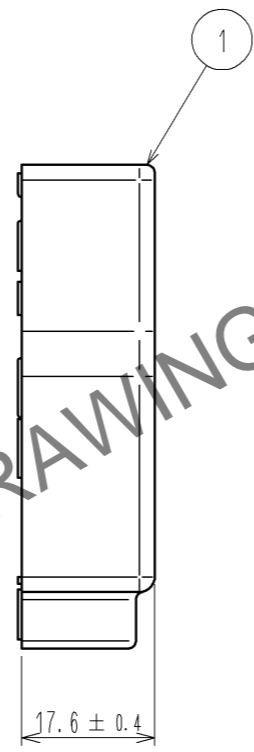
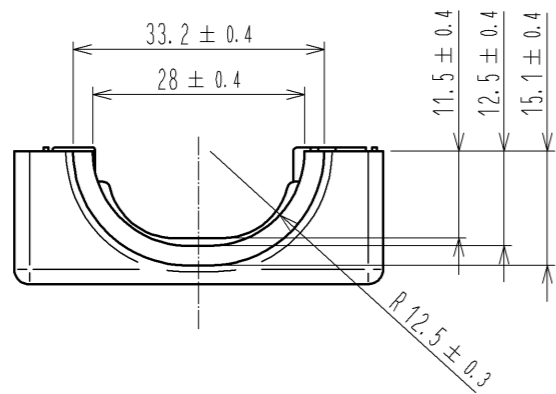
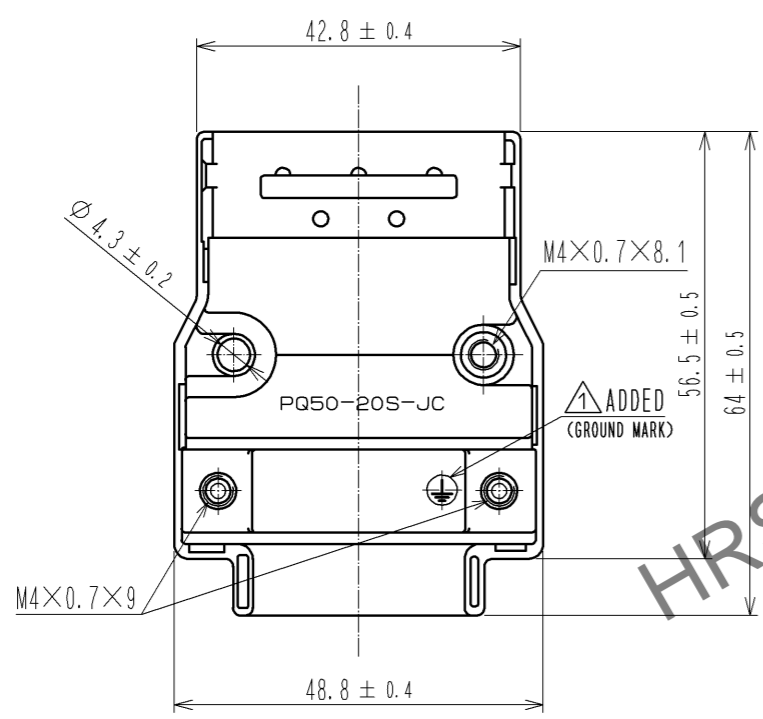
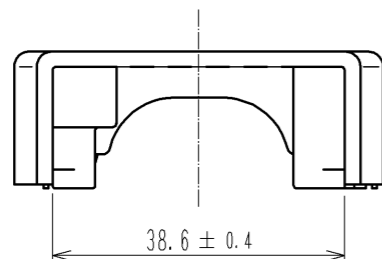
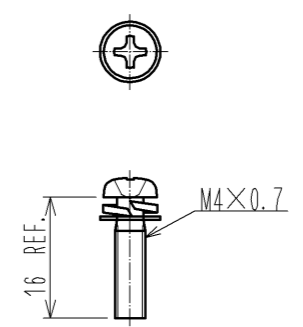

3 ELECTRODE TOUCHED AREA FOR RACK PLATING

HATCHED BOTTOM AREAS AND THE SIDE WALL UP TO 10 MAX. HIGH FROM THE BOTTOM SURFACE.

- NOTE 1. REFER TO ETAD-E 2925 FOR THE APPLICABLE COMPONENTS ASSEMBLED WITH THIS PRODUCT.  
2. SWELLING MAX 1.2mm DIA. AND 0.15mm HEIGHT COULD APPEAR ON THE SURFACE DUE TO DIE-CASTING, BUT IT DOESN'T AFFECT THE PERFORMANCE.  
3 THE COLOR OF HATCHED AREA COULD BE DIFFERENT DUE TO THE RACK PLATING PROCESS, TOUCHING THE ELECTRODES TO THE SPECIFIED AREA, BUT IT DOESN'T AFFECT THE PERFORMANCE.  
4. THIS PRODUCT IS AVAILABLE BY 100 pcs./box UNIT.

1	ZDC2	SURFACE PLATING : NICKEL UNDER PLATING : COPPER	2	STEEL	SURFACE PLATING : NICKEL UNDER PLATING : COPPER
NO.	MATERIAL	FINISH . REMARKS	NO.	MATERIAL	FINISH . REMARKS
UNITS mm		SCALE 1 : 1	COUNT 1	DESCRIPTION OF REVISIONS DIS-E-004870	DESIGNED TY. MIURA
		APPROVED : KN. ICHIKAWA 10. 09. 29	DRAWING NO. EDC3-126916-00		
HIROSE ELECTRIC CO., LTD.		CHECKED : KN. ICHIKAWA 10. 09. 29	PART NO. PQ50-20S-JC		
		DESIGNED : TY. MIURA 10. 09. 29	CODE NO. CL236-2002-3-00		
		DRAWN : TF. HIGASHIYAMA 10. 09. 25	DATE 13. 12. 09		