

1. Scope of application:

This specification document describes the cable assembly process for the PQ50W series plug connector.

2. Applicable connector:

	Product name	Product code	Remarks
Plug connector	PQ50W-50-PCA	CL236-2133-0-00	
Clamp connector	i) PQW-CM(15.0)	CL236-2104-0-00	Applicable for outer diameter ϕ 15.0 mm
	ii) PQW-CM(17.5)	CL236-2019-6-00	Applicable for outer diameter ϕ 17.5 mm
Housing	PQ50WS-25P-UNIT	CL236-2021-8-00	2 pieces
 PQ50S2 crimping contact	Refer to "Crimping contact list" on the next page.		

For a proper and satisfactory assembly result, only an applicator or a hand tool should be used. Regarding the handling of the hand tool, please refer to the corresponding instruction manual.

3. Applicable cable:

Final diameter : 15.0 mm

Recommended cable : —



Final diameter : 17.5 mm

Recommended cable : DAIDEN Co., Ltd. HRZEV-ESLAB(2464)

4. Commercial items:

The following commercial items are necessary to assembly the ground connection and should be prepared in advance:

- cross recessed head screw with captive washer M3x4
- ring crimping contact R1.25-3

COUNT	DESCRIPTION OF REVISIONS	DESIGNED	CHECKED	DATE
 5	DIS-E-00014667	KIM JAEHYEON	KG. OKITA	20230913
TITLE		HRS HIROSE ELECTRIC CO., LTD.		
PQ50W plug connector assembly instruction manual		APPROVED	RI. TAKAYASU	20140709
		CHECKED	NM. NISHIMATSU	20140709
		DESIGNED	KG. OKITA	20140708
		WRITTEN	KG. OKITA	20140708
TECHNICAL SPECIFICATION		ETAD-E3011-00		1 / 8

Crimping contact list



Type	Packing form	Component	Required quantity	Part No.	CL No.	Remarks
Male side (P Side)	Reel packaging (6000 pcs/reel)	Male crimp contact (standard contact)	① Required number *	PQ50S2-1618PCFA	CL236-0032-0	Applicable wire : UL1007 AWG#16~18
			② Required number *	PQ50S2-1822PCFA	CL236-0035-0	Applicable wire : UL1007 AWG#18~22
			③ Required number *	PQ50S2-2428PCFA	CL236-0038-0	Applicable wire : UL1007 AWG#24~28
		Male crimp contact (sequence contact)	④ Required number *	PQ50SA2-1618PCFA	CL236-0033-0	Applicable wire : UL1007 AWG#16~18
			⑤ Required number *	PQ50SA2-1822PCFA	CL236-0034-0	Applicable wire : UL1007 AWG#18~22
			⑥ Required number *	PQ50SA2-2428PCFA	CL236-0037-0	Applicable wire : UL1007 AWG#24~28
	Plastic bag packaging (100 pcs/bag)	Male crimp contact (standard contact)	⑦ Required number *	PQ50S2-1822PCA	CL236-0046-0	Applicable wire : UL1007 AWG#18~22
			⑧ Required number *	PQ50S2-2428PCA	CL236-0047-0	Applicable wire : UL1007 AWG#24~28
		Male crimp contact (sequence contact)	⑨ Required number *	PQ50SA2-1822PCA	CL236-0048-0	Applicable wire : UL1007 AWG#18~22
			⑩ Required number *	PQ50SA2-2428PCA	CL236-0049-0	Applicable wire : UL1007 AWG#24~28
Type	Packing form	Component	Required quantity	Part No.	CL No.	Remarks
Female side (S Side)	Reel packaging (6000 pcs/reel)	Female crimp contact (standard contact)	① Required number *	PQ50S2-1618SCFA	CL236-0042-0	Applicable wire : UL1007 AWG#16~18
			② Required number *	PQ50S2-1822SCFA	CL236-0036-0	Applicable wire : UL1007 AWG#18~22
			③ Required number *	PQ50S2-2428SCFA	CL236-0039-0	Applicable wire : UL1007 AWG#24~28
	Plastic bag packaging (100 pcs/bag)	Female crimp contact (standard contact)	④ Required number *	PQ50S2-1822SCA	CL236-0050-0	Applicable wire : UL1007 AWG#18~22
			⑤ Required number *	PQ50S2-2428SCA	CL236-0051-0	Applicable wire : UL1007 AWG#24~28

*Prepare as to your application

Apr.1.2026 Copyright 2026 HIROSE ELECTRIC CO., LTD. All Rights Reserved.

5. Assemble procedure:

5-1. Cutting the cable:

Please cut the cable at the required length L plus an additional length of 80 mm for assembly purpose.

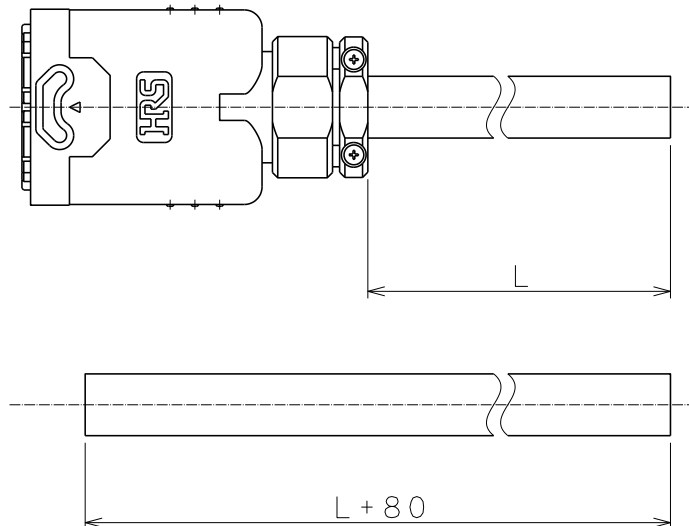

5-2. Handling of the cable contact:

Assembly the following parts in the right order starting by the clamp A, resuming with the gasket, and lastly by putting on the cover.

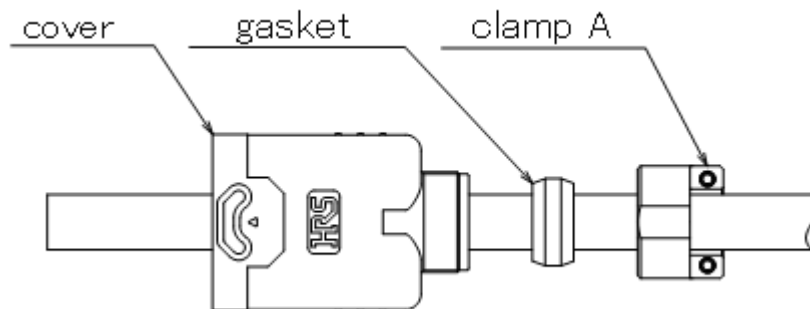

Remove 50 ± 5 mm of the cable jacket at the cable end.

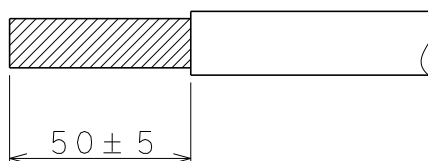

Cut off the cable shield foil, STP shield foil, the STP drain line and the filling material such as threads to the same point as the cable jacket before. Trim the exposed drain wire to 40 mm length.

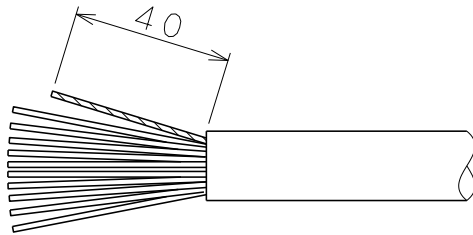

If the drain wire differs from the figure above, please braid the separated wires together and solder them like in the following figure.

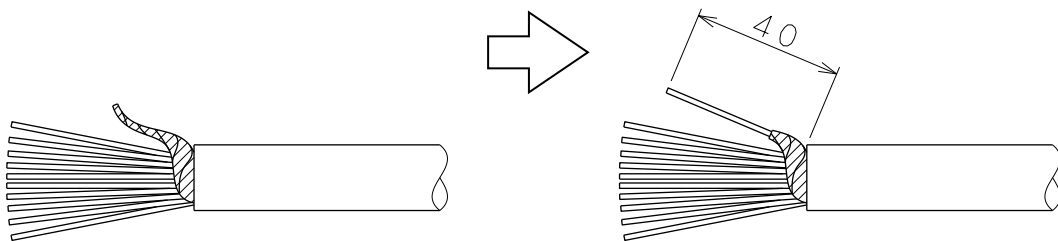

Strip the insulation of the inner wires to a length between 3 and 3.5 mm.

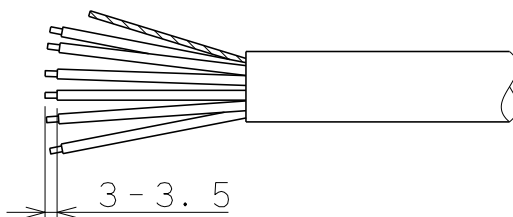

3 5-3. Contact crimping:

Use only an applicator or a corresponding hand tool for the crimping of the PQ50S2 contact. Please refer to the crimp quality standards shown in the ATAD-E3237 and ATAD-E3238. Assemble the already prepared commercial ring contact with the remaining drain wire by using a commercial crimping tool.

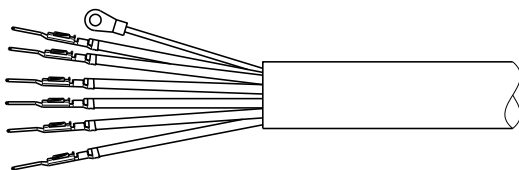

5-4. Insertion of the contacts:

Insert the just crimped wires into the P-housing. During the insertion process a Click feeling should be confirmed. The identification numbers of the insertion holes of the P-housing case is shown below.

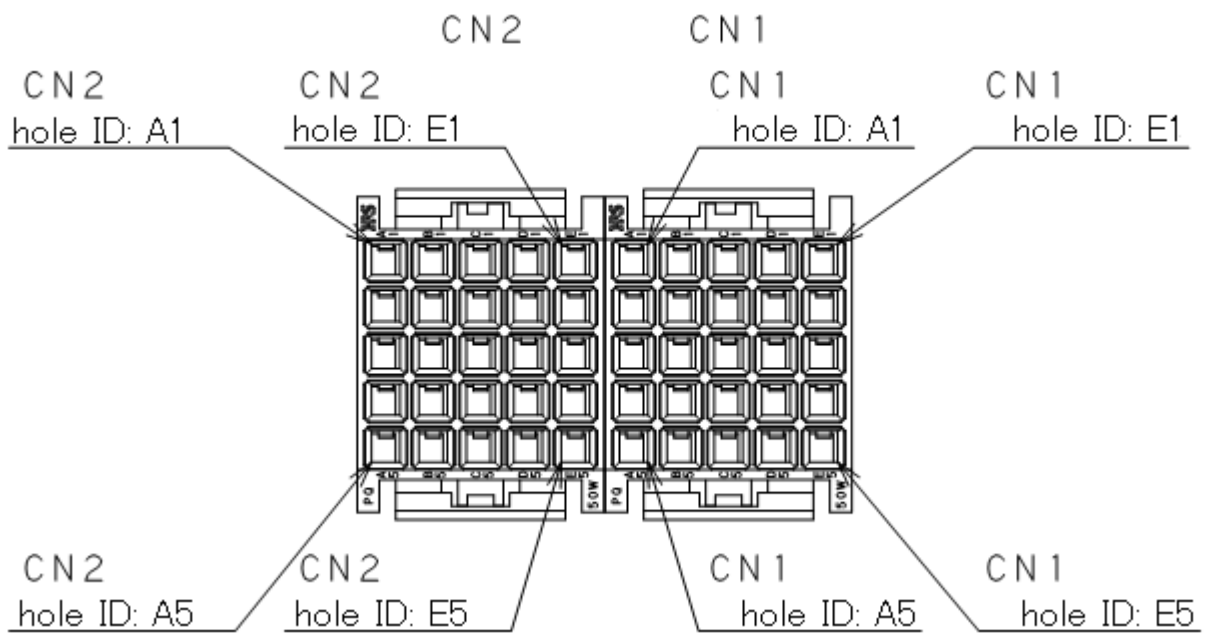
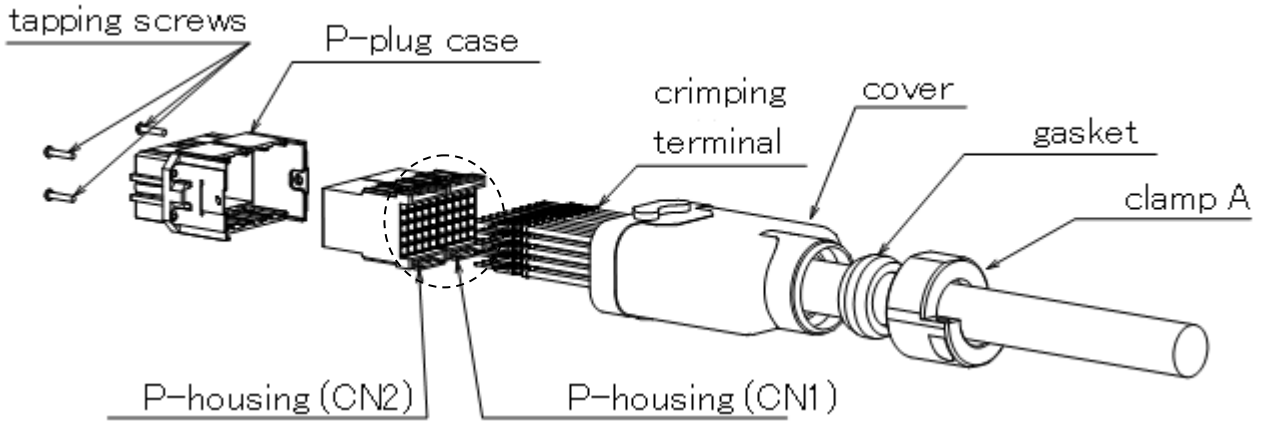

5-5. Insertion of the P-housing:

Insert the P-housing into the P-plug case. Be sure to perceive a click feeling by doing so. By inserting it properly you will realize that the upper and bottom plastic spring of the P-housing will engage into the P-Plug case.

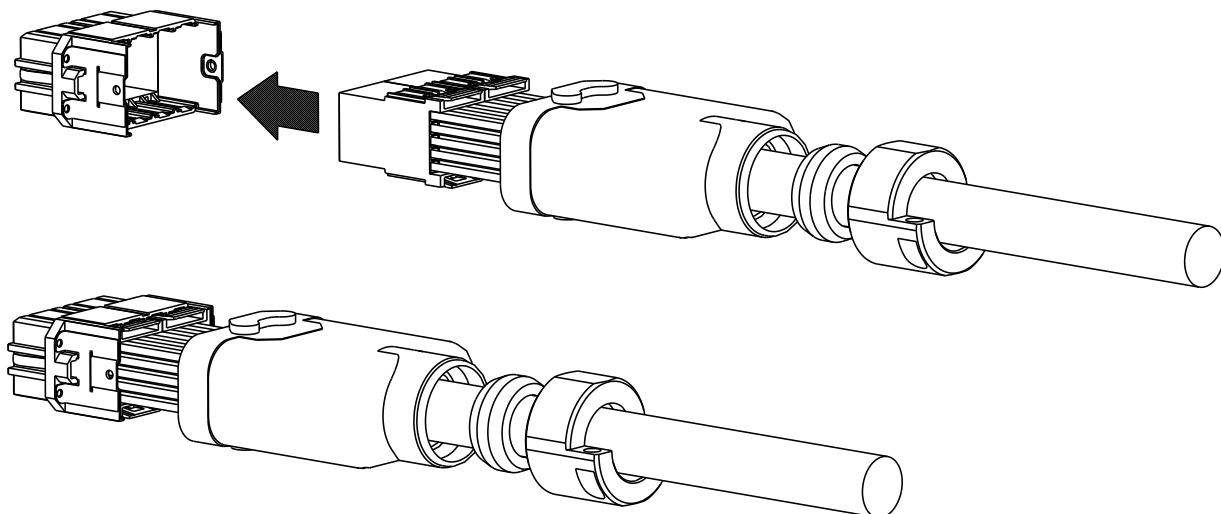

5-6. Fastening the drain wire:

Please tighten the drain wire to one of the grounding plates of the P-plug case. Feel free to choose either the left or the right grounding plate.

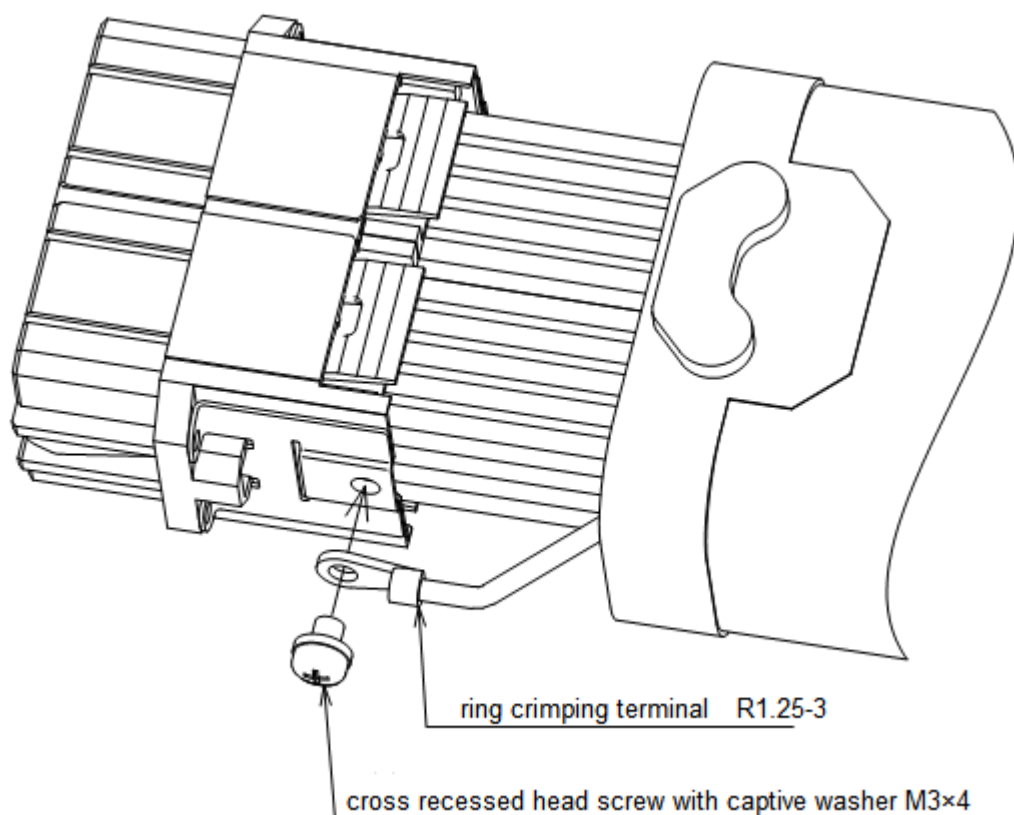

Screw tightening torque : 0.6 ± 0.1 [Nm]

5-7. Assembly of the cover:

Please adjust the tension of the cables so that the length between the P-plug case and the end of the striped cable jacket is 25 mm MAX.

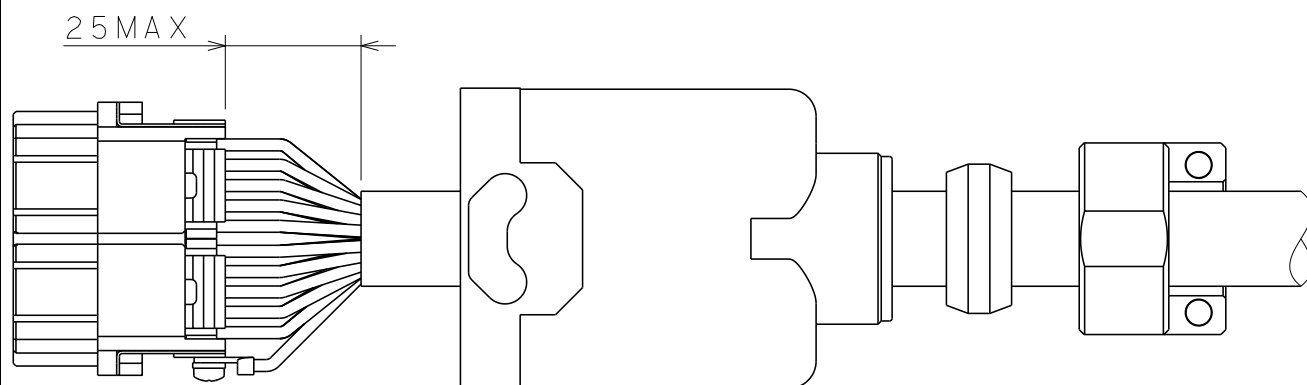

After sliding the cover over the P-plug case, screw it together with the self-tapping screws at the 4 corresponding places.

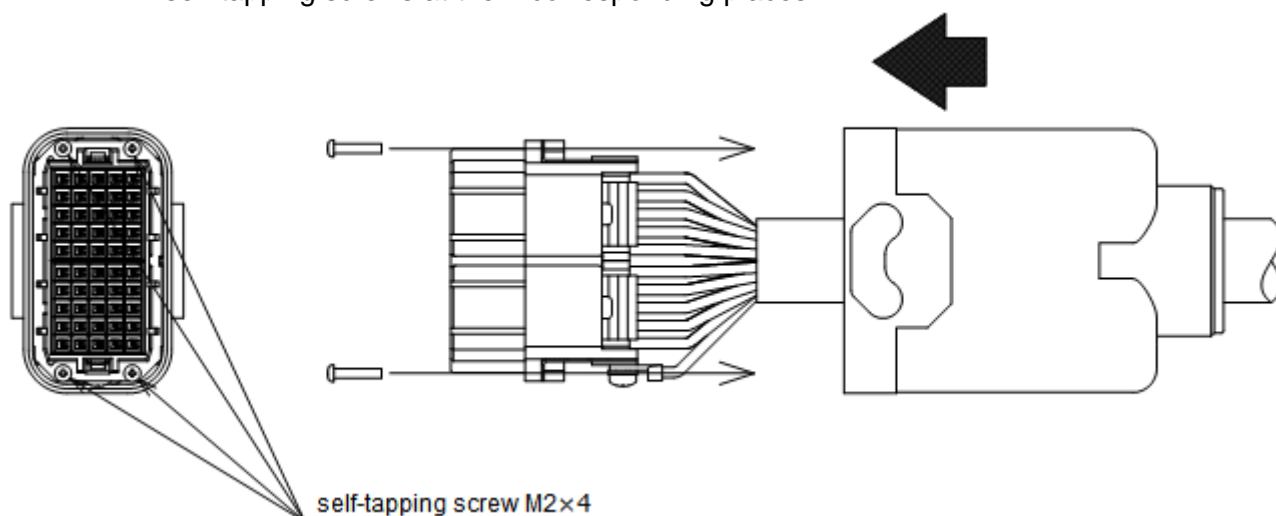

Screw tightening torque : 0.2 ± 0.1 [Nm]

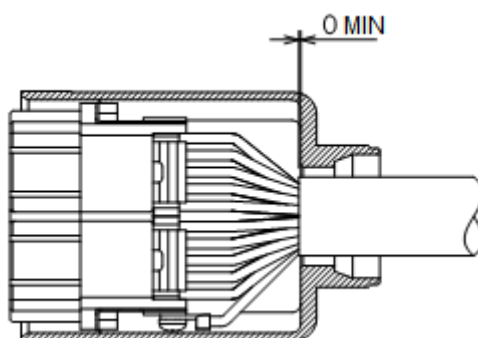

Confirm that the cable jacket has been inserted within the interior of the cover as shown in the figure above. If that is not the case, continue pushing the cable until the jacket has reached it. At the same time, please be sure to not overstrain the connector and the contacts with excessive force.

5-8. Tightening clamp A:

After pushing the gasket till it reaches the cover, screw the clamp A over the gasket.

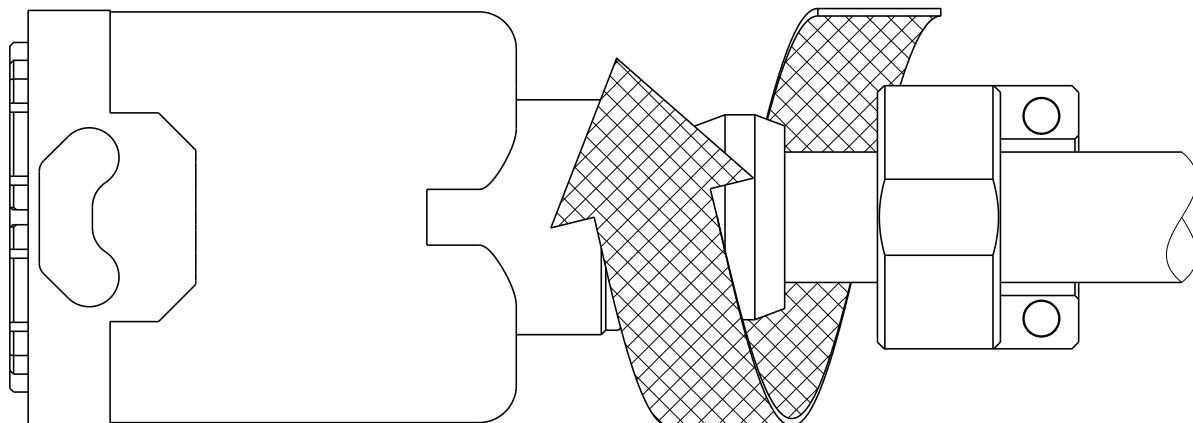

Screw tightening torque : 9 ± 0.5 [Nm]

5-9. Tightening clamp B:

To finish the assembly, mount clamp B onto clamp A.

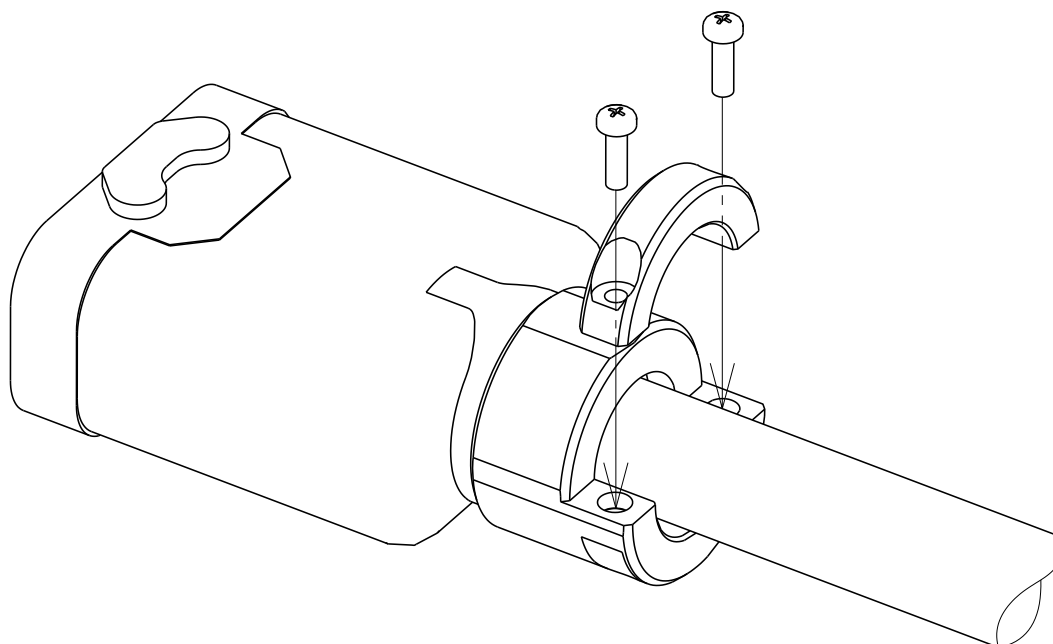

Screw tightening torque : 0.6 ± 0.1