

Oct.1.2024 Copyright 2024 HIROSE ELECTRIC CO., LTD. All Rights Reserved.
 In case of consideration for using Automotive equipment / device which demand high reliability, kindly contact our sales window correspondents.

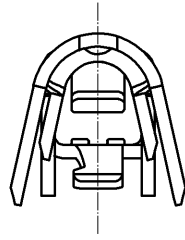
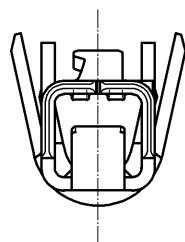
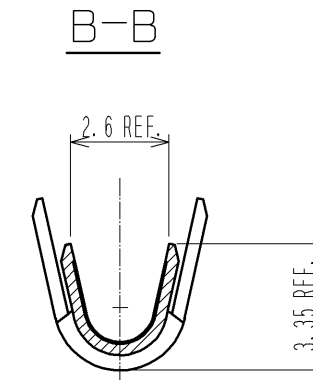
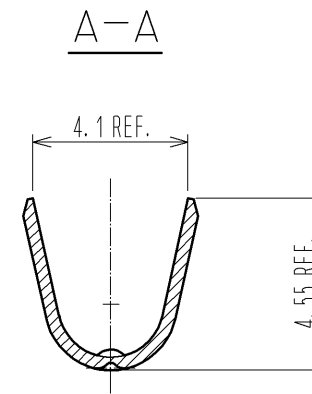
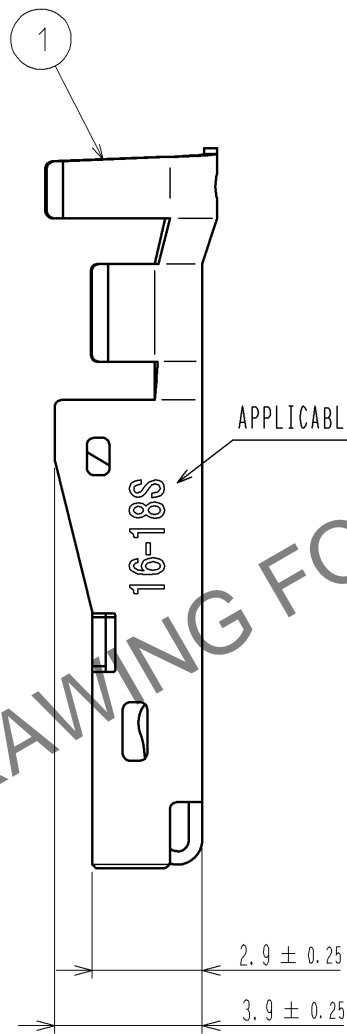
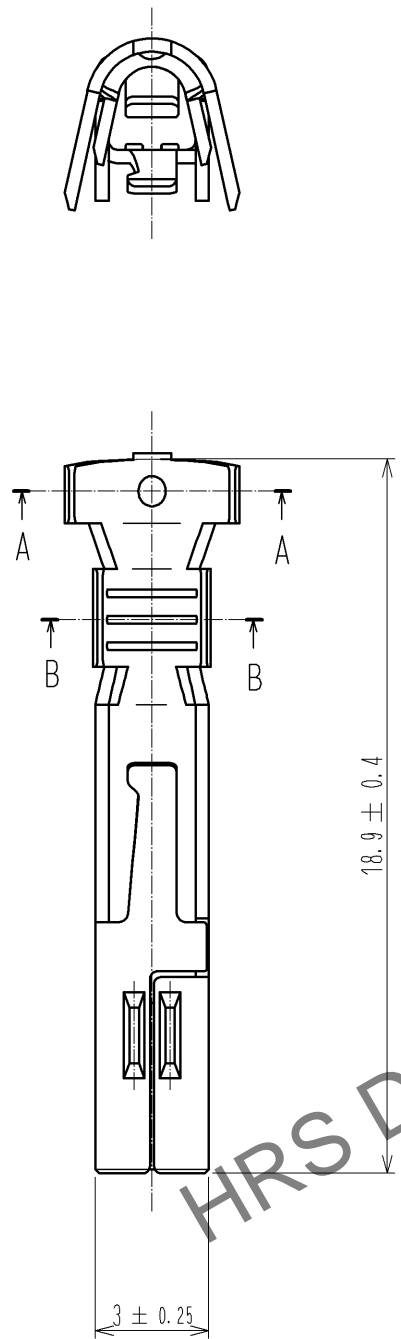
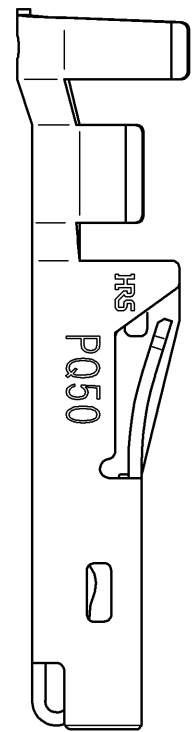

HRS DRAWING FOR REFERENCE

- NOTES
1. APPLICABLE WIRE IS AWG #16~#18. (UL1007, UL1015) INSULATION DIAMETER ϕ 3.30mm MAX.
 2. APPLICABLE CRIMPING MACHINE AND CRIMPING CONDITIONS (CRIMP HEIGHT etc.) WILL BE SPECIFIED ACCORDING TO AWG # OR WIRE APPLIED.
 3. ONE PACKAGE CONSISTS OF 100 PCS.
 4. REFER TO ATAI-E3038 FOR CRIMP QUALITY STANDARDS.

NO.		MATERIAL		FINISH . REMARKS		NO.		MATERIAL		FINISH . REMARKS	
		1		COPPER ALLOY				CONTACT AREA : GOLD PLATING 0.2 μ m MIN.		TERMINAL AREA : TIN PLATING 1 μ m MIN.	
								UNDER PLATING : NICKEL PLATING 0.5 μ m MIN.			
UNITS		SCALE		COUNT		DESCRIPTION OF REVISIONS		DESIGNED		CHECKED	
mm		5 : 1		1		DIS-E-004910		TY. MIURA		NM. NISHIMATSU	
						APPROVED : RI. TAKAYASU 12.12.11		DRAWING NO.		EDC3-128191-00	
						CHECKED : AH. KODAMA 12.12.11		PART NO.		PQ50-1618SCA	
						DESIGNED : TY. MIURA 12.12.10		CODE NO.		CL236-2044-3-00	
						DRAWN : TY. MIURA 12.12.10				1/1	