

Apr.1.2026 Copyright 2026 HIROSE ELECTRIC CO., LTD. All Rights Reserved.
 In case of consideration for using Automotive equipment / device which demand high reliability, kindly contact our sales window correspondents.

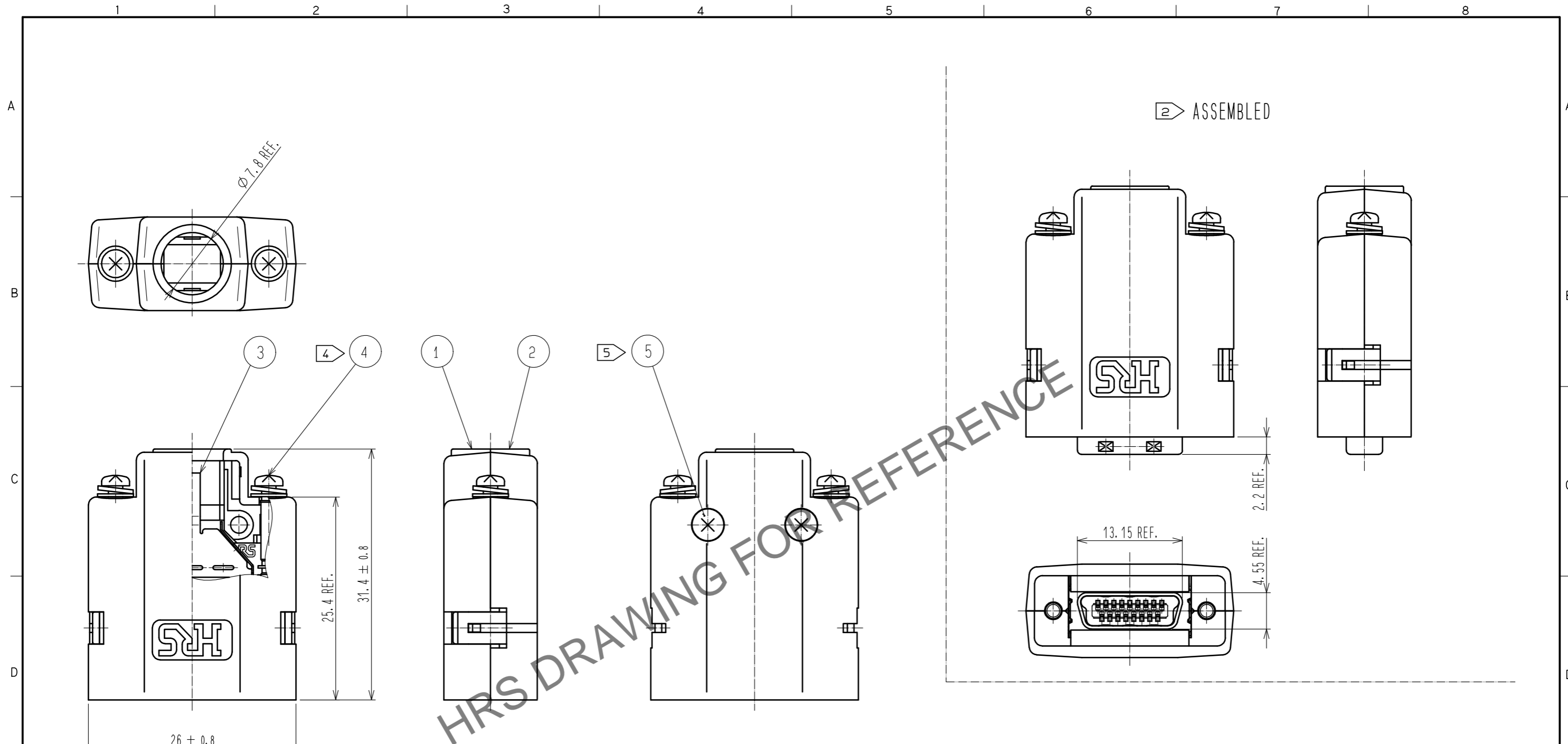

- NOTE 1. THIS PRODUCT IS DELIVERED SEPARATELY.
 2 AS SHOWN IN THE FIGURE, THIS PRODUCT SHALL BE USED ASSEMBLED TO A CONNECTOR UNIT 'DH40-17S' or 'DH3+B-17S'. A CLAMP 'DH-17-CMB(6.3)' IS NEEDED WHEN ASSEMBLING THE UNIT.
 3. THIS PRODUCT SHALL BE MATED WITH A RECEPTACLE 'DH60-17P*' WHICH ASSEMBLED LOCK SCREWS 'DH-LNA***'.
 4 A RECOMMENDED SCREW TIGHTENING TORQUE TO THE LOCK SCREWS TO BE FROM 0.06 TO 0.07 N · m.
 5 A RECOMMENDED SCREW TIGHTENING TORQUE FOR COVERS TO BE FROM 0.1 TO 0.15 N · m.

NO.	MATERIAL	FINISH . REMARKS	NO.	MATERIAL	FINISH . REMARKS
3	STAINLESS STEEL	PLATING : NICKEL 0.1 μm MIN	5	STEEL	TRIVALENT BLACK CHROMATE
2	PC	UL94V-0 (BLACK)	4	STEEL	OVER PLATING : NICKEL 2 μm MIN UNDER PLATING : COPPER 1 μm MIN M2×0.4
1					

UNITS	SCALE	COUNT	DESCRIPTION OF REVISIONS	DESIGNED	CHECKED	DATE
mm	2 : 1	1	DIS-E-00002570	TS. ITO	TU. TANIGUCHI	20191007

APPROVED : A0. SUZUKI	20090416	DRAWING NO.	EDC-126586-00-00
CHECKED : MO. SHIMOYAMA	20090416	PART NO.	DH-17-CV1B
DESIGNED : TS. ITO	20090416	CODE NO.	CL244-0009-6-00
DRAWN : TS. ITO	20090416		

Apr.1.2026 Copyright 2026 HIROSE ELECTRIC CO., LTD. All Rights Reserved.
In case of consideration for using Automotive equipment / device which demand high reliability, kindly contact our sales window correspondents.

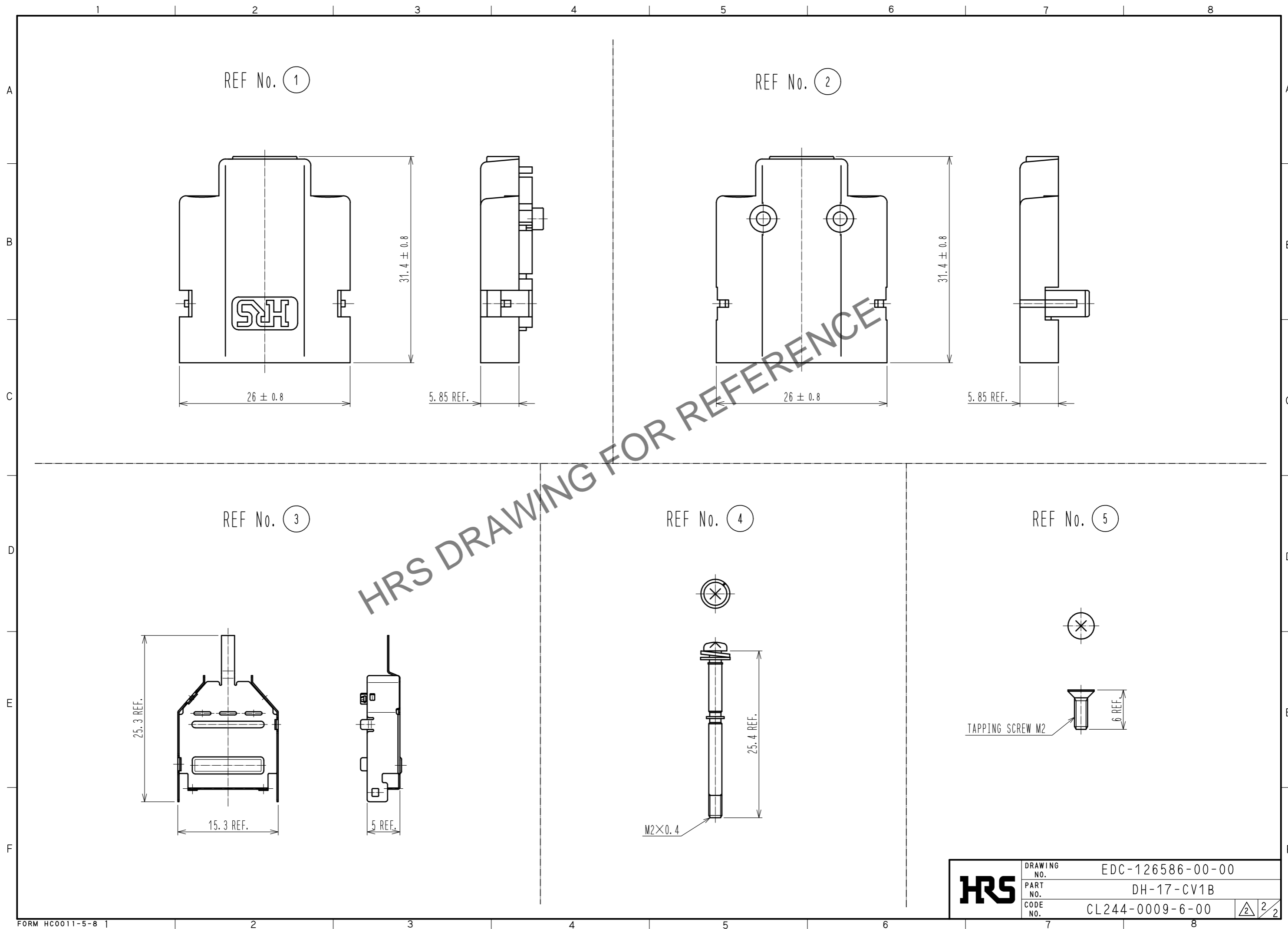

HRS	DRAWING NO.	EDC-126586-00-00
	PART NO.	DH-17-CV1B
	CODE NO.	CL244-0009-6-00
		2/2