

Aug.1.2024 Copyright 2024 HIROSE ELECTRIC CO., LTD. All Rights Reserved.
In case of consideration for using Automotive equipment / device which demand high reliability, kindly contact our sales window correspondents.

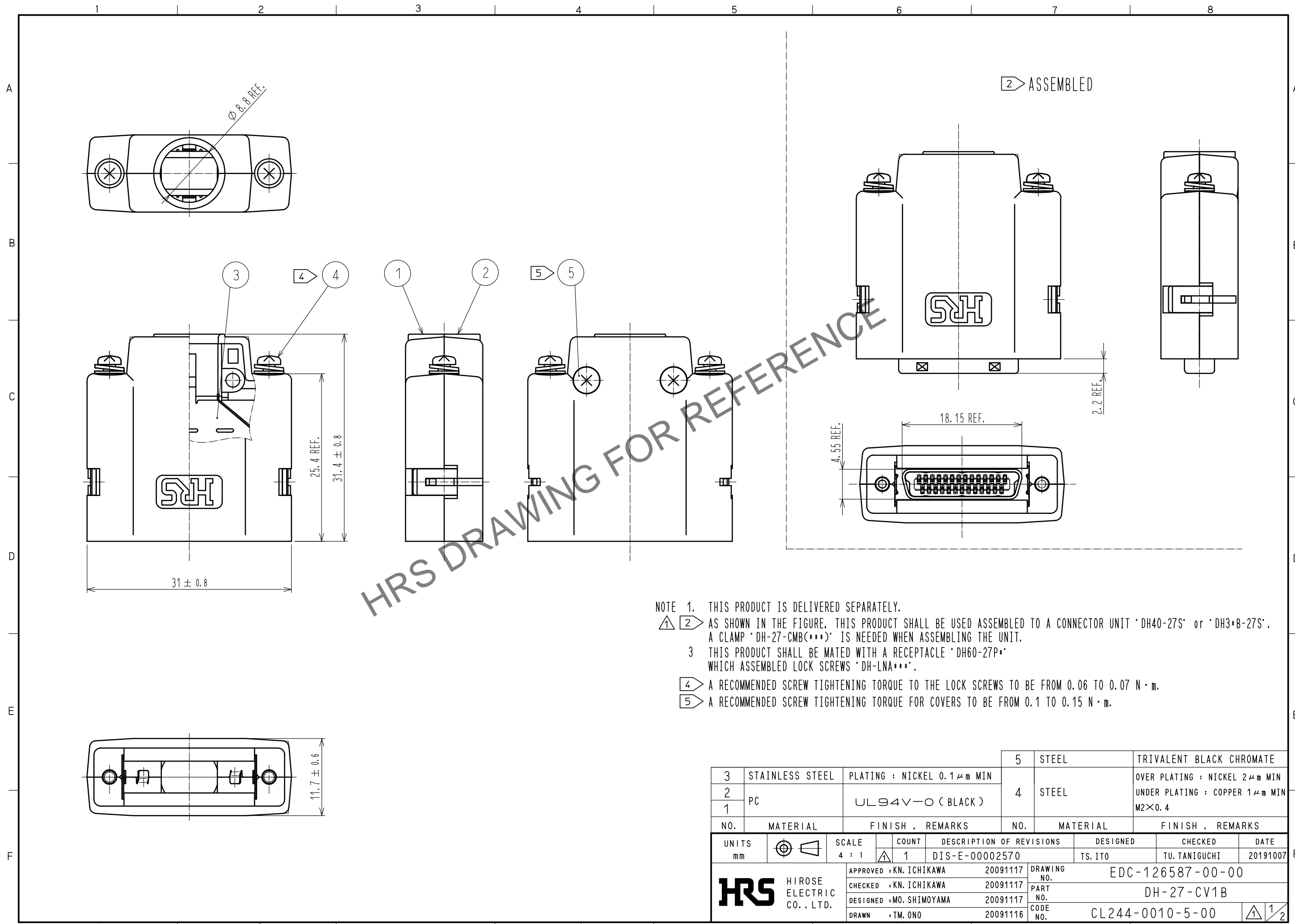

- NOTE 1. THIS PRODUCT IS DELIVERED SEPARATELY.
 1 2 AS SHOWN IN THE FIGURE, THIS PRODUCT SHALL BE USED ASSEMBLED TO A CONNECTOR UNIT 'DH40-27S' or 'DH3+B-27S'. A CLAMP 'DH-27-CMB(***)' IS NEEDED WHEN ASSEMBLING THE UNIT.
 3 THIS PRODUCT SHALL BE MATED WITH A RECEPTACLE 'DH60-27P*' WHICH ASSEMBLED LOCK SCREWS 'DH-LNA***'.
 4 A RECOMMENDED SCREW TIGHTENING TORQUE TO THE LOCK SCREWS TO BE FROM 0.06 TO 0.07 N · m.
 5 A RECOMMENDED SCREW TIGHTENING TORQUE FOR COVERS TO BE FROM 0.1 TO 0.15 N · m.

3	STAINLESS STEEL	PLATING : NICKEL 0.1 μm MIN	5	STEEL	TRIVALENT BLACK CHROMATE
2	PC	UL94V-O (BLACK)	4	STEEL	OVER PLATING : NICKEL 2 μm MIN
1					UNDER PLATING : COPPER 1 μm MIN
NO.	MATERIAL	FINISH . REMARKS	NO.	MATERIAL	FINISH . REMARKS
UNITS mm		SCALE 4 : 1	COUNT 1	DESCRIPTION OF REVISIONS DIS-E-00002570	
APPROVED : KN. ICHIKAWA 20091117			DESIGNED TS. ITO	CHECKED TU. TANIGUCHI	
CHECKED : KN. ICHIKAWA 20091117			DATE 20191007		
DESIGNED : MO. SHIMOYAMA 20091117			DRAWING NO. EDC-126587-00-00		
DRAWN : TM. ONO 20091116			PART NO. DH-27-CV1B		
HRS HIROSE ELECTRIC CO., LTD.			CODE NO. CL244-0010-5-00		

Aug.1.2024 Copyright 2024 HIROSE ELECTRIC CO., LTD. All Rights Reserved.
In case of consideration for using Automotive equipment / device which demand high reliability, kindly contact our sales window correspondents.

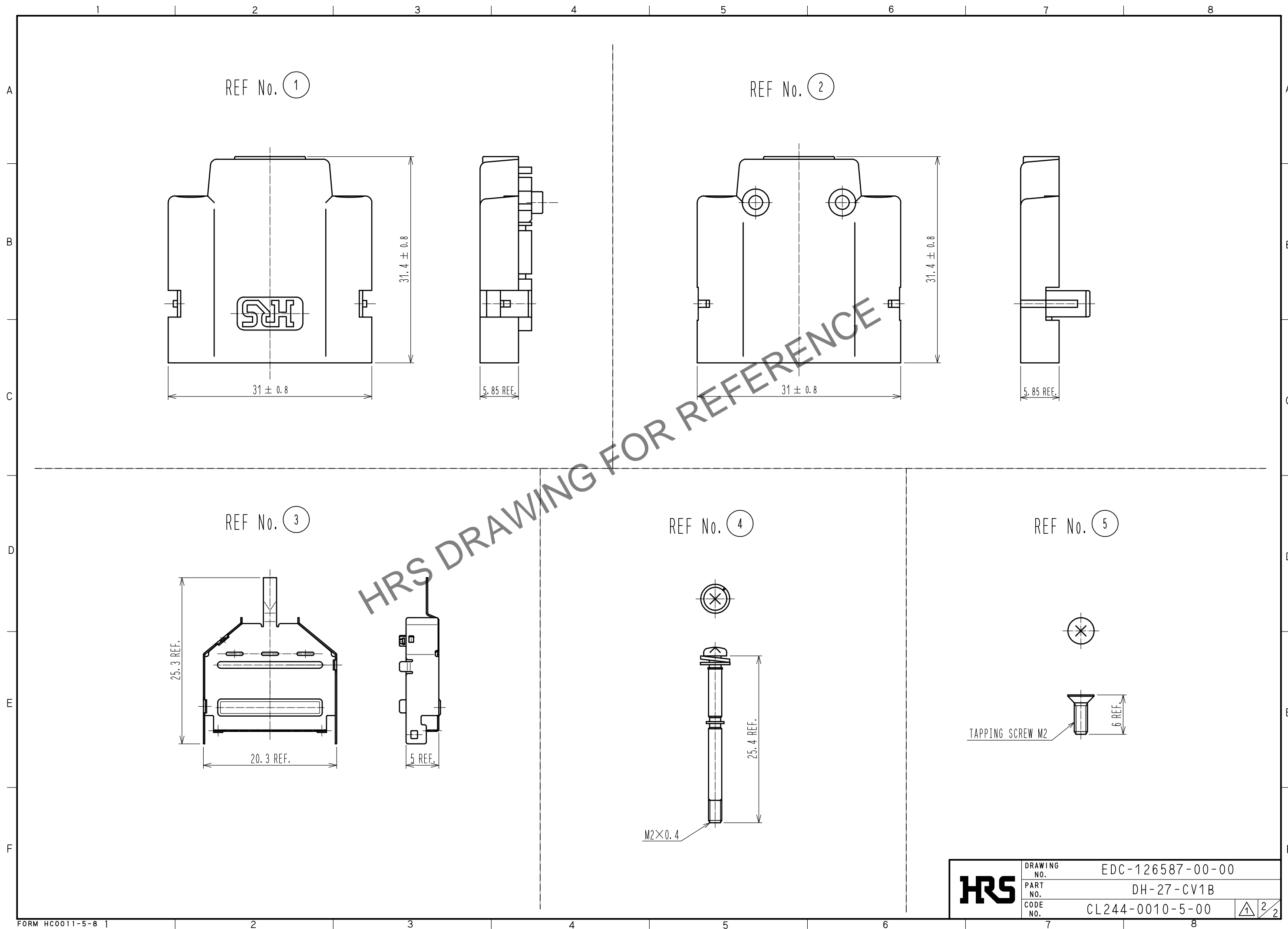

HRS	DRAWING NO.	EDC-126587-00-00
	PART NO.	DH-27-CV1B
	CODE NO.	CL244-0010-5-00
		2/2