

May.1.2026 Copyright 2026 HIROSE ELECTRIC CO., LTD. All Rights Reserved.
In case of consideration for using Automotive equipment / device which demand high reliability, kindly contact our sales window correspondents.

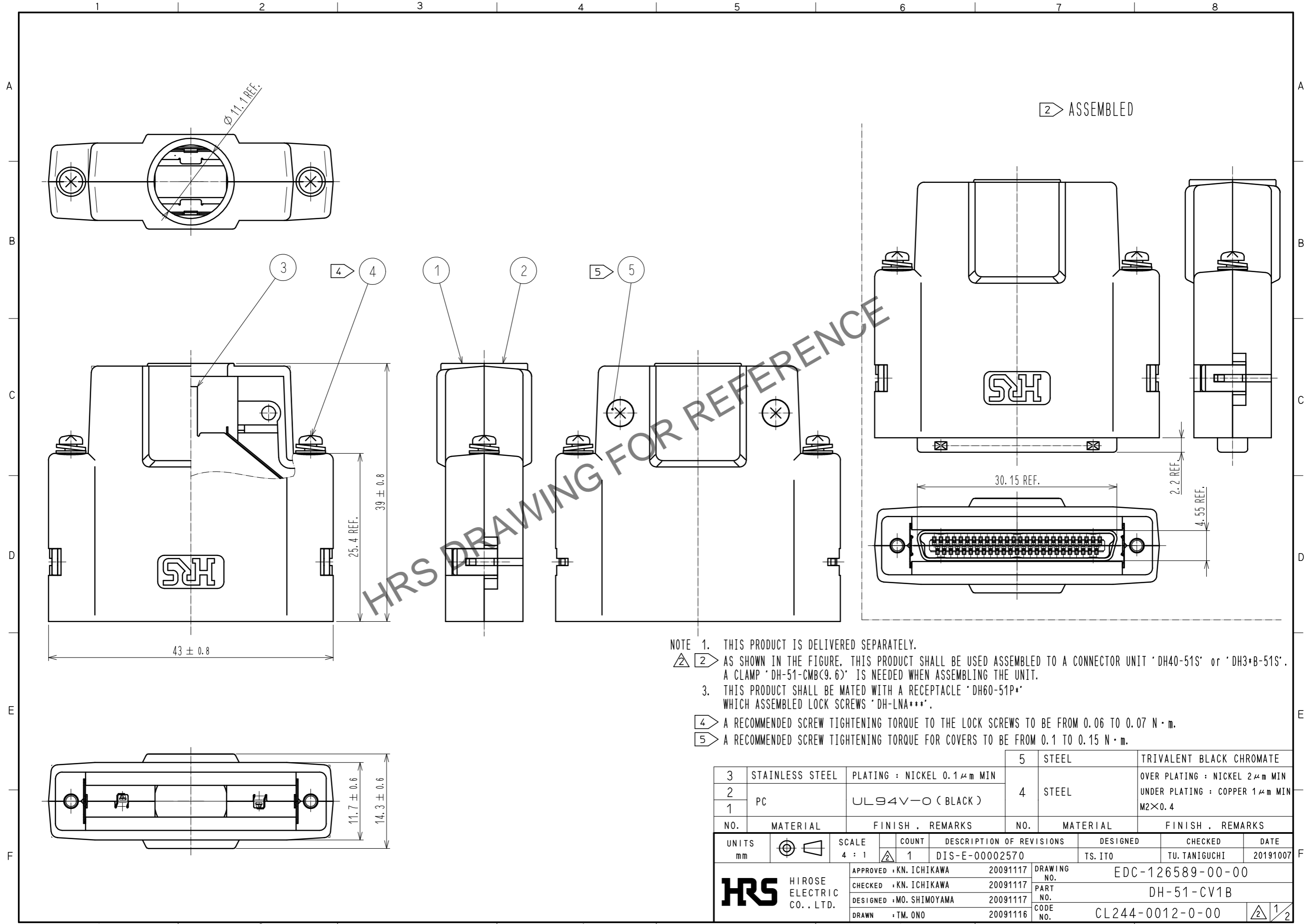

- NOTE 1. THIS PRODUCT IS DELIVERED SEPARATELY.
 2 AS SHOWN IN THE FIGURE, THIS PRODUCT SHALL BE USED ASSEMBLED TO A CONNECTOR UNIT 'DH40-51S' or 'DH3+B-51S'. A CLAMP 'DH-51-CMB(9.6)' IS NEEDED WHEN ASSEMBLING THE UNIT.
 3. THIS PRODUCT SHALL BE MATED WITH A RECEPTACLE 'DH60-51P*' WHICH ASSEMBLED LOCK SCREWS 'DH-LNA***'.
 4 A RECOMMENDED SCREW TIGHTENING TORQUE TO THE LOCK SCREWS TO BE FROM 0.06 TO 0.07 N · m.
 5 A RECOMMENDED SCREW TIGHTENING TORQUE FOR COVERS TO BE FROM 0.1 TO 0.15 N · m.

3	STAINLESS STEEL	PLATING : NICKEL 0.1 μm MIN	5	STEEL	TRIVALENT BLACK CHROMATE
2	PC	UL94V-0 (BLACK)	4	STEEL	OVER PLATING : NICKEL 2 μm MIN
1					UNDER PLATING : COPPER 1 μm MIN
NO.	MATERIAL	FINISH . REMARKS	NO.	MATERIAL	FINISH . REMARKS
UNITS	mm	SCALE	4 : 1	COUNT	1
		DESCRIPTION OF REVISIONS	DESIGNED	CHECKED	DATE
		DIS-E-00002570	TS. ITO	TU. TANIGUCHI	20191007
APPROVED : KN. ICHIKAWA		20091117	DRAWING NO. EDC-126589-00-00		
CHECKED : KN. ICHIKAWA		20091117	PART NO. DH-51-CV1B		
DESIGNED : MO. SHIMOYAMA		20091117	CODE NO. CL244-0012-0-00		
DRAWN : TM. ONO		20091116	1/2		

May.1.2026 Copyright 2026 HIROSE ELECTRIC CO., LTD. All Rights Reserved.
In case of consideration for using Automotive equipment / device which demand high reliability, kindly contact our sales window correspondents.

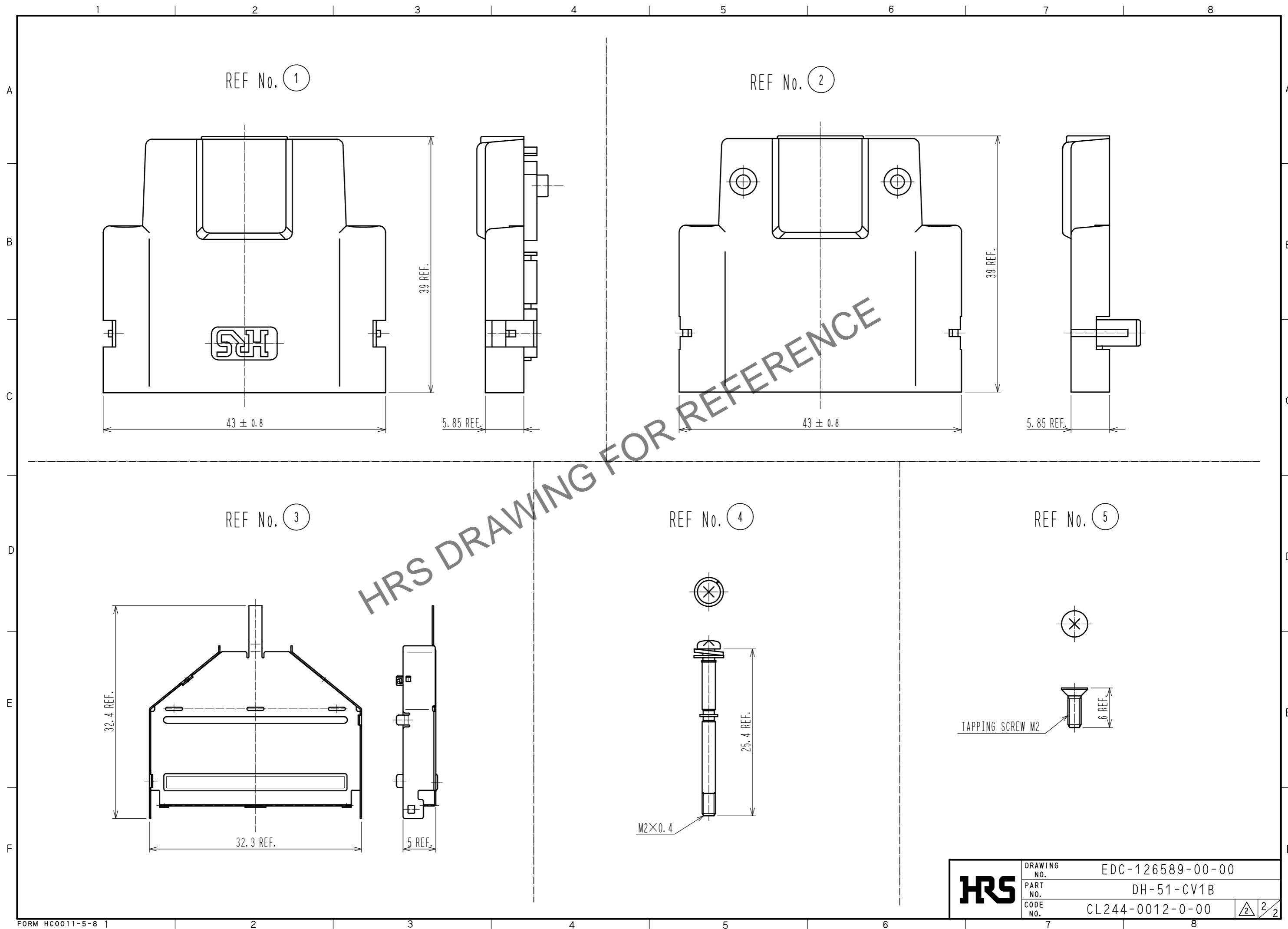

HRS	DRAWING NO.	EDC-126589-00-00
	PART NO.	DH-51-CV1B
	CODE NO.	CL244-0012-0-00
		2/2