

Aug.1.2024 Copyright 2024 HIROSE ELECTRIC CO., LTD. All Rights Reserved.
 In case of consideration for using Automotive equipment / device which demand high reliability, kindly contact our sales window correspondents.

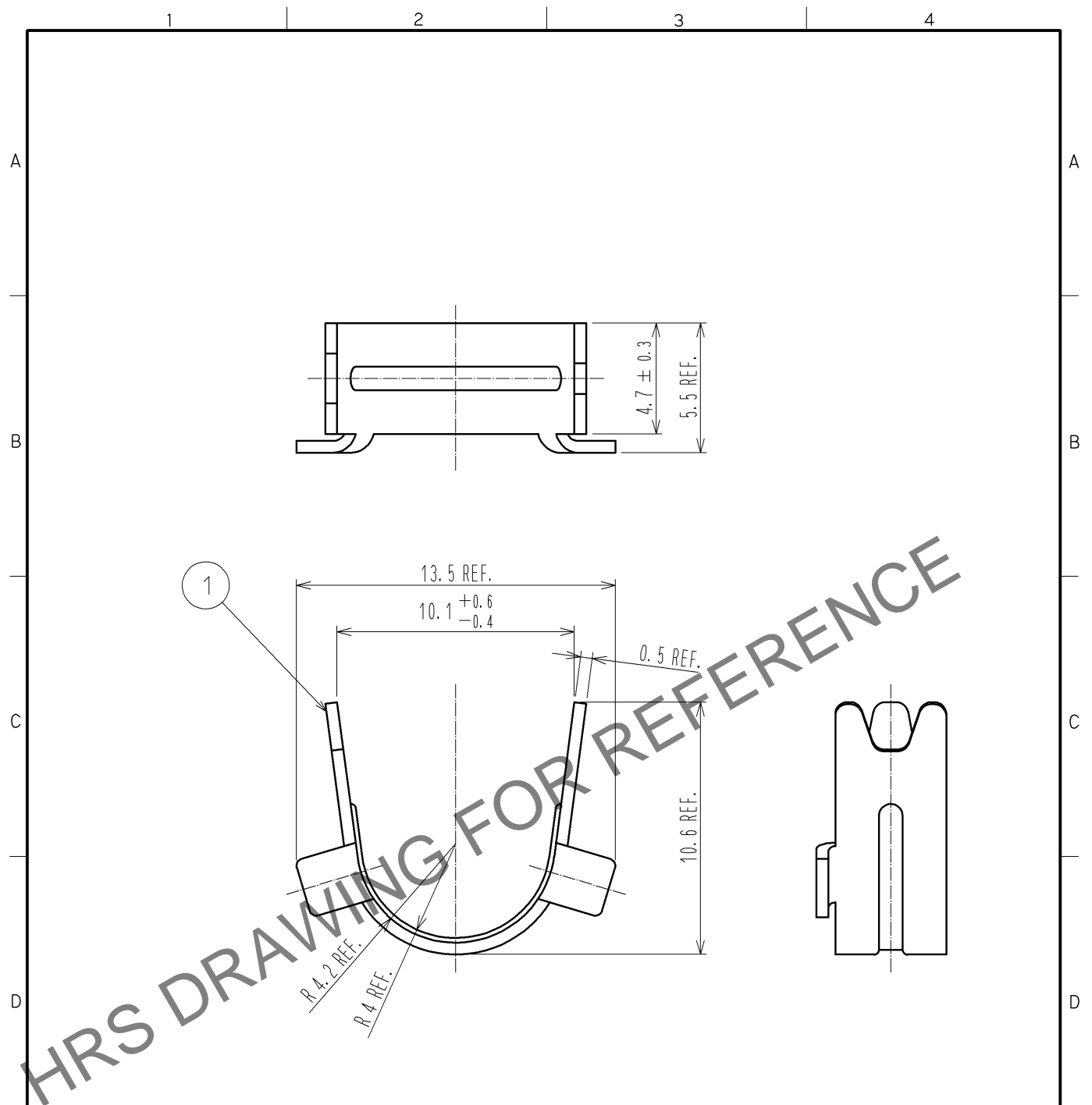

HRS DRAWING FOR REFERENCE

NOTE 1. THIS PRODUCT IS A CLAMP FOR A COVER CASE 'DH-27-C**B'.
 2. THE APPLICABLE CABLE DIAMETER IS $\phi 6.9$.
 △ 3. THIS PRODUCT IS PACKED IN A BAG.
 (QUANTITY PER BAG MAY VARY DUE TO THE AMOUNT OF EACH ORDER.)

NO.		MATERIAL		FINISH . REMARKS		1		BRASS		FINISH . REMARKS			
UNITS mm		SCALE 4 : 1		COUNT △ 1		DESCRIPTION OF REVISIONS DIS-E-003059		DESIGNED MO. SHIMOYAMA		CHECKED KN. ICHIKAWA		DATE 09.12.07	
HIROSE ELECTRIC CO., LTD.		APPROVED : AO. SUZUKI		09.05.07		DRAWING NO.		EDC4-126674-00					
		CHECKED : KN. ICHIKAWA		09.05.07		PART NO.		DH-27-CMB(6.9)					
		DESIGNED : MO. SHIMOYAMA		09.05.07		CODE NO.		CL244-0036-9-00					
		DRAWN : MO. SHIMOYAMA		09.05.07						△ 1		1	