

Mar.1.2026 Copyright 2026 HIROSE ELECTRIC CO., LTD. All Rights Reserved.
In case of consideration for using Automotive equipment / device which demand high reliability, kindly contact our sales window correspondents.

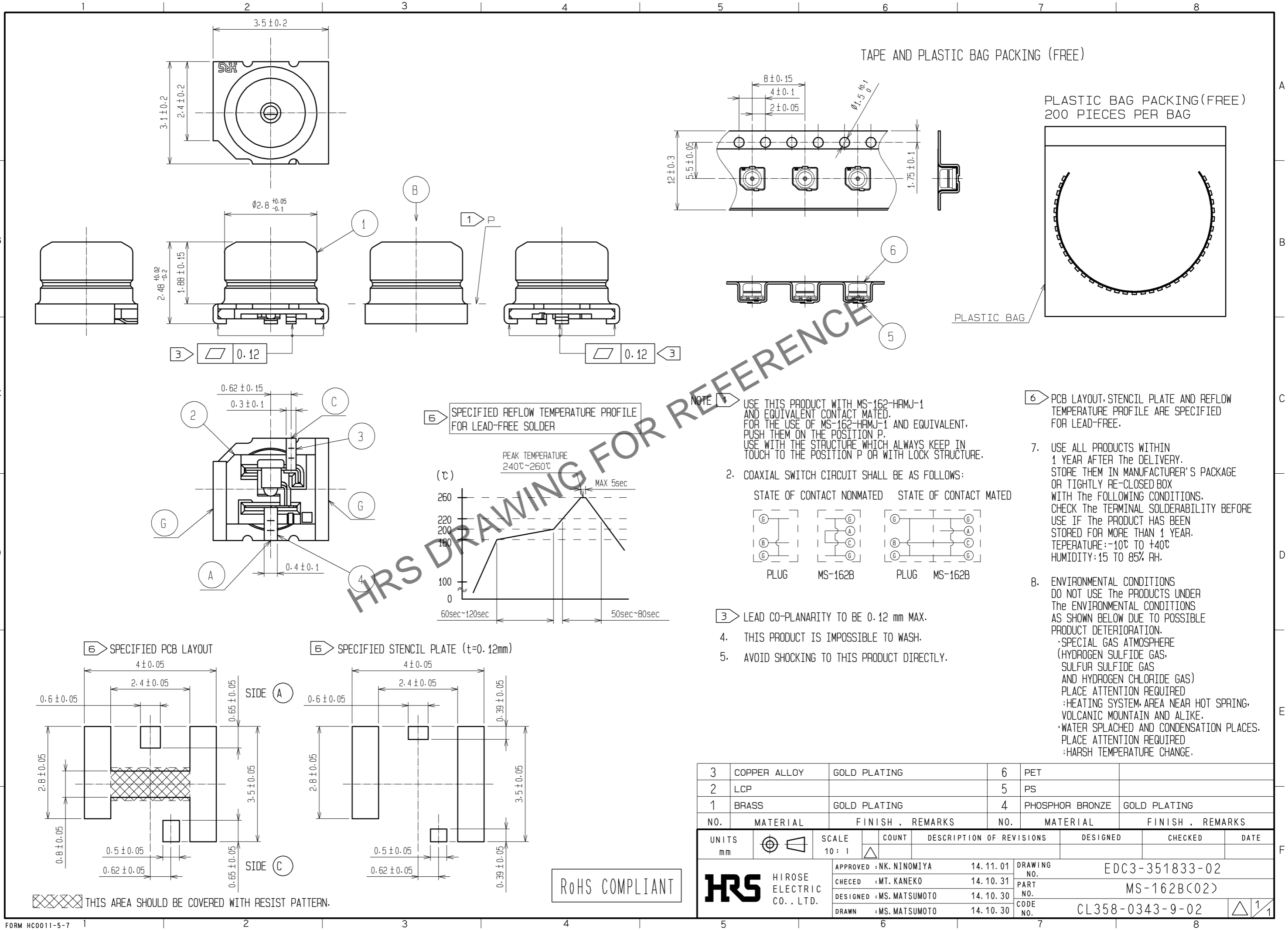

TAPE AND PLASTIC BAG PACKING (FREE)

PLASTIC BAG PACKING(FREE)
200 PIECES PER BAG

6 SPECIFIED REFLOW TEMPERATURE PROFILE FOR LEAD-FREE SOLDER

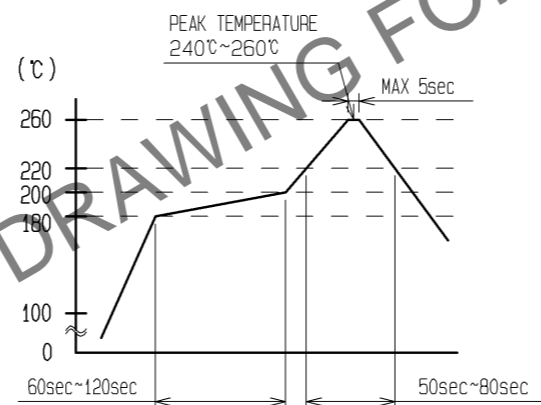

NOTE USE THIS PRODUCT WITH MS-162-HRMJ-1 AND EQUIVALENT CONTACT MATED. FOR THE USE OF MS-162-HRMJ-1 AND EQUIVALENT, PUSH THEM ON THE POSITION P. USE WITH THE STRUCTURE WHICH ALWAYS KEEP IN TOUCH TO THE POSITION P OR WITH LOCK STRUCTURE.

2. COAXIAL SWITCH CIRCUIT SHALL BE AS FOLLOWS:

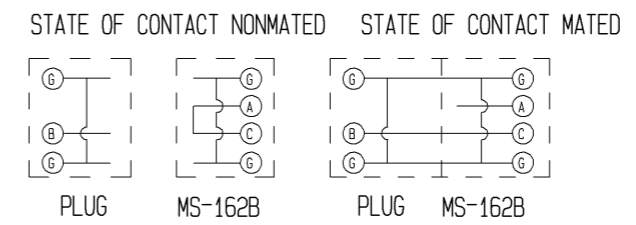

- 3 LEAD CO-PLANARITY TO BE 0.12 mm MAX.
- 4 THIS PRODUCT IS IMPOSSIBLE TO WASH.
- 5 AVOID SHOCKING TO THIS PRODUCT DIRECTLY.

6 PCB LAYOUT, STENCIL PLATE AND REFLOW TEMPERATURE PROFILE ARE SPECIFIED FOR LEAD-FREE.

7. USE ALL PRODUCTS WITHIN 1 YEAR AFTER THE DELIVERY. STORE THEM IN MANUFACTURER'S PACKAGE OR TIGHTLY RE-CLOSED BOX WITH THE FOLLOWING CONDITIONS. CHECK THE TERMINAL SOLDERABILITY BEFORE USE IF THE PRODUCT HAS BEEN STORED FOR MORE THAN 1 YEAR. TEMPERATURE: -10°C TO +40°C HUMIDITY: 15 TO 85% RH.

8. ENVIRONMENTAL CONDITIONS DO NOT USE THE PRODUCTS UNDER THE ENVIRONMENTAL CONDITIONS AS SHOWN BELOW DUE TO POSSIBLE PRODUCT DETERIORATION.
·SPECIAL GAS ATMOSPHERE (HYDROGEN SULFIDE GAS, SULFUR SULFIDE GAS AND HYDROGEN CHLORIDE GAS) PLACE ATTENTION REQUIRED
·HEATING SYSTEM, AREA NEAR HOT SPRING, VOLCANIC MOUNTAIN AND ALIKE.
·WATER SPLASHED AND CONDENSATION PLACES. PLACE ATTENTION REQUIRED
·HARSH TEMPERATURE CHANGE.

3	COPPER ALLOY	GOLD PLATING	6	PET	
2	LCP		5	PS	
1	BRASS	GOLD PLATING	4	PHOSPHOR BRONZE	GOLD PLATING
NO.	MATERIAL	FINISH . REMARKS	NO.	MATERIAL	FINISH . REMARKS
UNITS mm		SCALE 10:1	COUNT		DESCRIPTION OF REVISIONS
					DESIGNED
					CHECKED
					DATE
APPROVED : NK. NINOMIYA			14. 11. 01		
CHECED : MT. KANEKO			14. 10. 31		
DESIGNED : MS. MATSUMOTO			14. 10. 30		
DRAWN : MS. MATSUMOTO			14. 10. 30		
DRAWING NO.				EDC3-351833-02	
PART NO.				MS-162B(02)	
CODE NO.				CL358-0343-9-02	

RoHS COMPLIANT

THIS AREA SHOULD BE COVERED WITH RESIST PATTERN.