

Mar.1.2026 Copyright 2026 HIROSE ELECTRIC CO., LTD. All Rights Reserved.  
In case of consideration for using Automotive equipment / device which demand high reliability, kindly contact our sales window correspondents.

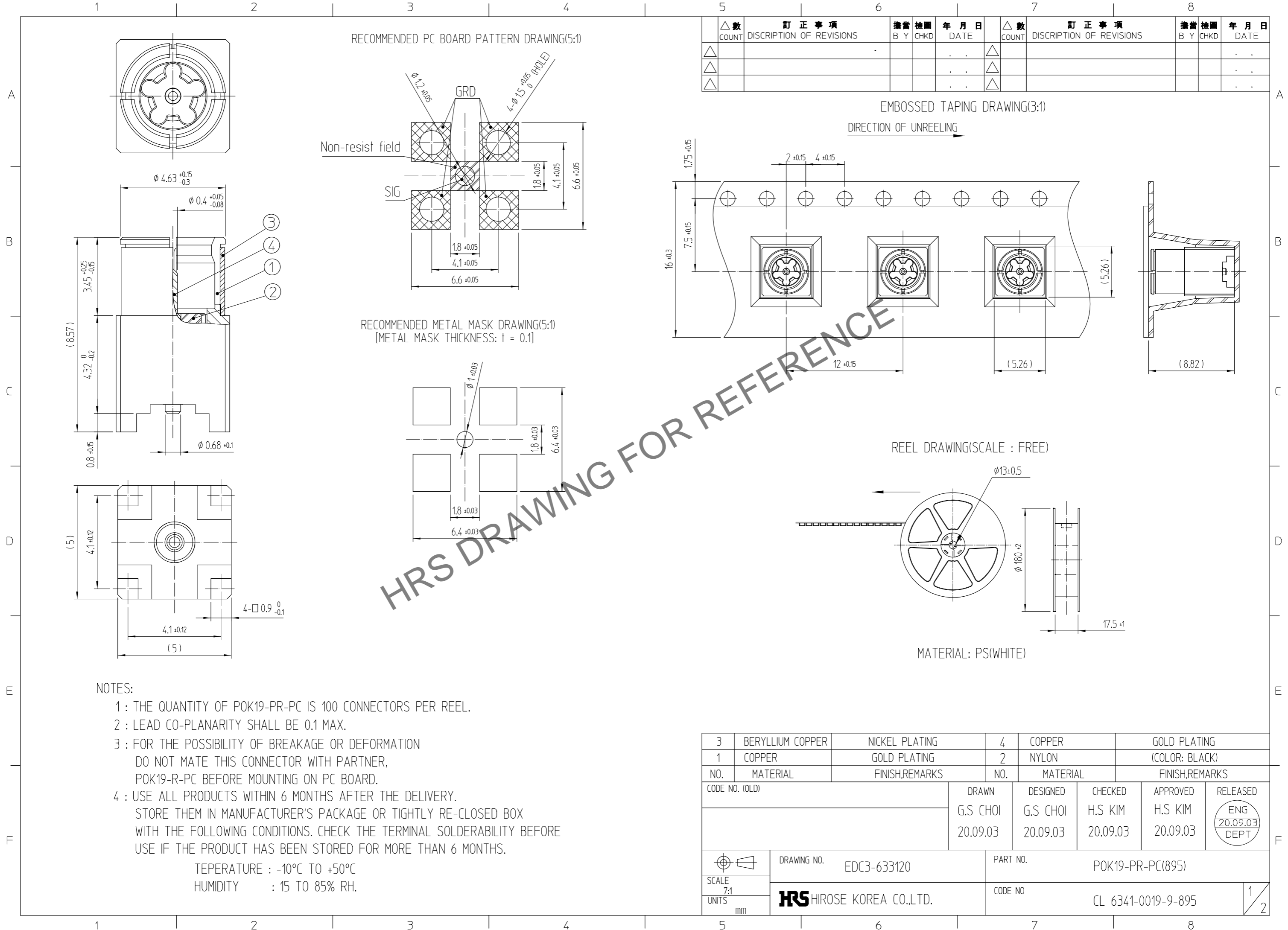

△數 COUNT	訂正事項 DISCRIPTION OF REVISIONS	擔當 B Y	檢圖 CHKD	年月日 DATE	△數 COUNT	訂正事項 DISCRIPTION OF REVISIONS	擔當 B Y	檢圖 CHKD	年月日 DATE
△					△				
△					△				
△					△				

NOTES:

- 1 : THE QUANTITY OF POK19-PR-PC IS 100 CONNECTORS PER REEL.
- 2 : LEAD CO-PLANARITY SHALL BE 0.1 MAX.
- 3 : FOR THE POSSIBILITY OF BREAKAGE OR DEFORMATION DO NOT MATE THIS CONNECTOR WITH PARTNER, POK19-R-PC BEFORE MOUNTING ON PC BOARD.
- 4 : USE ALL PRODUCTS WITHIN 6 MONTHS AFTER THE DELIVERY. STORE THEM IN MANUFACTURER'S PACKAGE OR TIGHTLY RE-CLOSED BOX WITH THE FOLLOWING CONDITIONS. CHECK THE TERMINAL SOLDERABILITY BEFORE USE IF THE PRODUCT HAS BEEN STORED FOR MORE THAN 6 MONTHS.

TEMPERATURE : -10°C TO +50°C  
HUMIDITY : 15 TO 85% RH.

3	BERYLLIUM COPPER	NICKEL PLATING	4	COPPER	GOLD PLATING
1	COPPER	GOLD PLATING	2	NYLON	(COLOR: BLACK)
NO.	MATERIAL	FINISH,REMARKS	NO.	MATERIAL	FINISH,REMARKS
CODE NO. (OLD)			DRAWN	DESIGNED	CHECKED
			G.S CHOI	G.S CHOI	H.S KIM
			20.09.03	20.09.03	20.09.03
			APPROVED	RELEASED	
			H.S KIM	H.S KIM	ENG
			20.09.03	20.09.03	20.09.03
			DEPT		
DRAWING NO. EDC3-633120			PART NO. POK19-PR-PC(895)		
SCALE 7:1			CODE NO. CL 6341-0019-9-895		
UNITS mm			HRS HIROSE KOREA CO.,LTD.		
					1/2

Mar.1.2026 Copyright 2026 HIROSE ELECTRIC CO., LTD. All Rights Reserved.  
In case of consideration for using Automotive equipment / device which demand high reliability, kindly contact our sales window correspondents.

※Handling notice

1. POK19-PR-PC

① Note the contact deformation of 'POK19-PR-PC' due to external objects.  
When contact is deformed and 'POK19-R-PC' is combined by contact deformation  
It can be a cause lose of function /not be combined/product damage  
(Including counterparties).

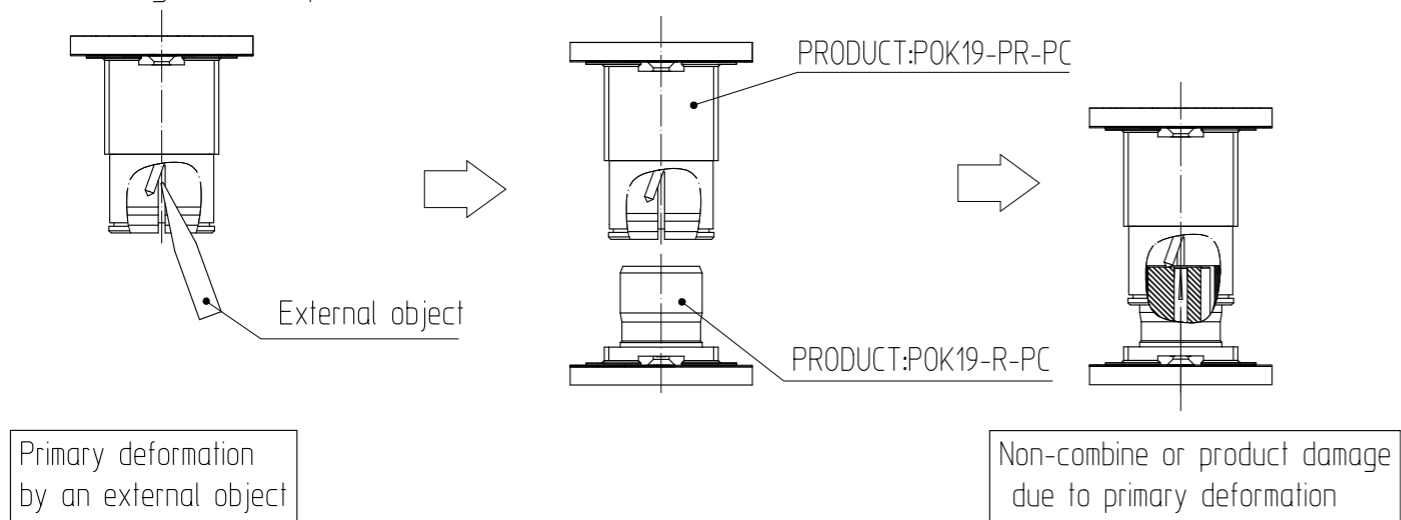

② When 'POK19-PR-PC' and 'POK19-R-PC' combine, there shall be no rotation.  
If the rotation of 'POK19-PR-PC' or 'POK19-R-PC' occurs in the process of coupling,  
contact is deformed. Contact deformation can be a cause lose of function/  
not be combined/product damage (Including counterparties).

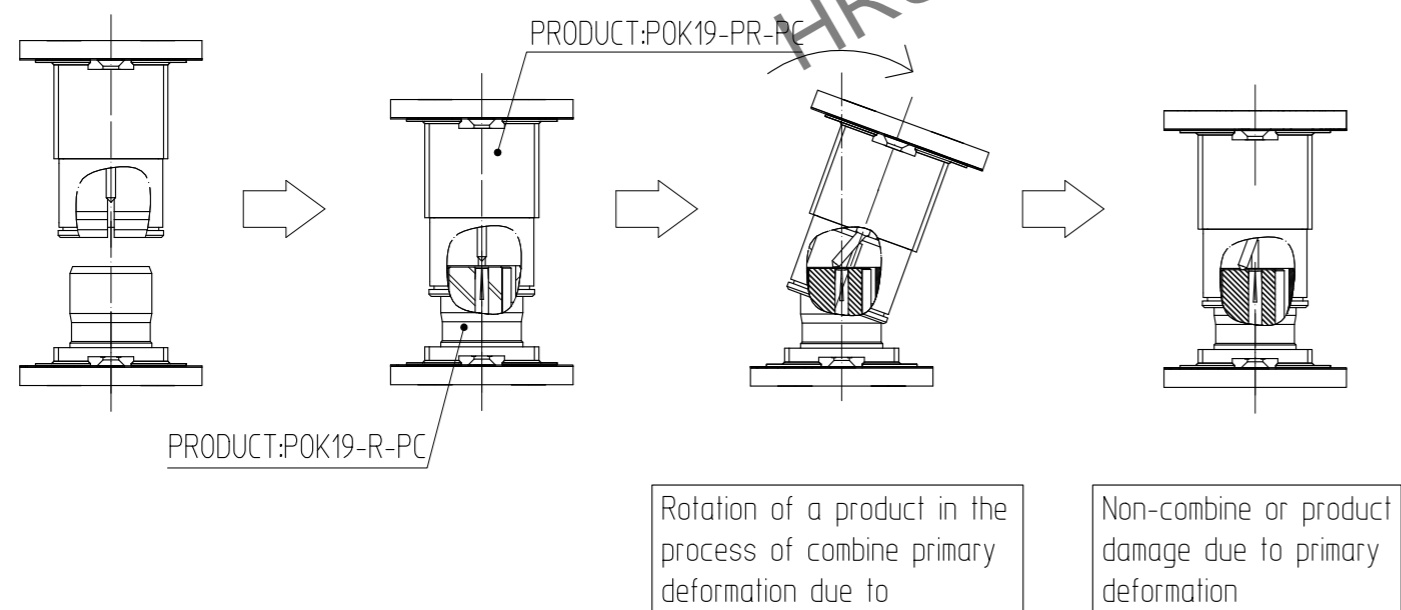

④ When using a combination of 'POK19-PR-PC' and 'POK19-R-PC',  
It is recommended to use JIG separately to maintain the coupling against  
external vibrations and shocks and to prevent move of the product.

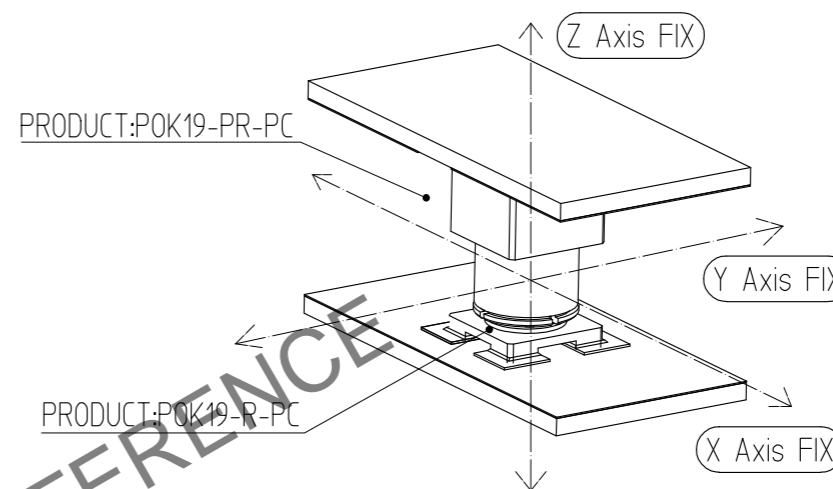

※Recommended method of coupling

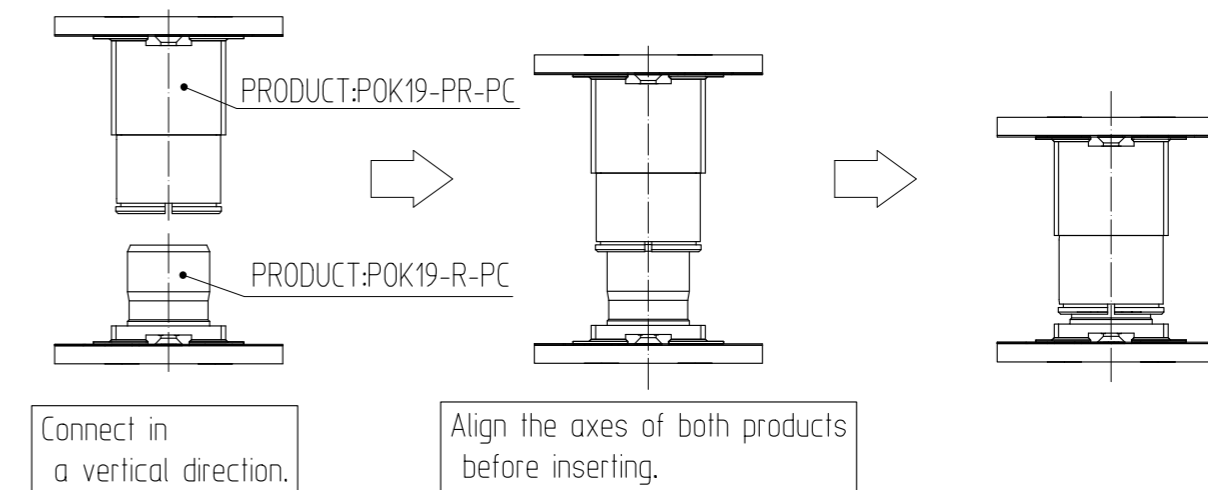

 SCALE 7:1 UNITS mm	DRAWING NO.	EDC3-633120	PART NO.	POK19-PR-PC(895)
	HIROSE KOREA CO.,LTD.		CODE NO.	CL 6341-0019-9-895
				2/2