

Feb.1.2026 Copyright 2026 HIROSE ELECTRIC CO., LTD. All Rights Reserved.
 In case of consideration for using Automotive equipment / device which demand high reliability, kindly contact our sales window correspondents.

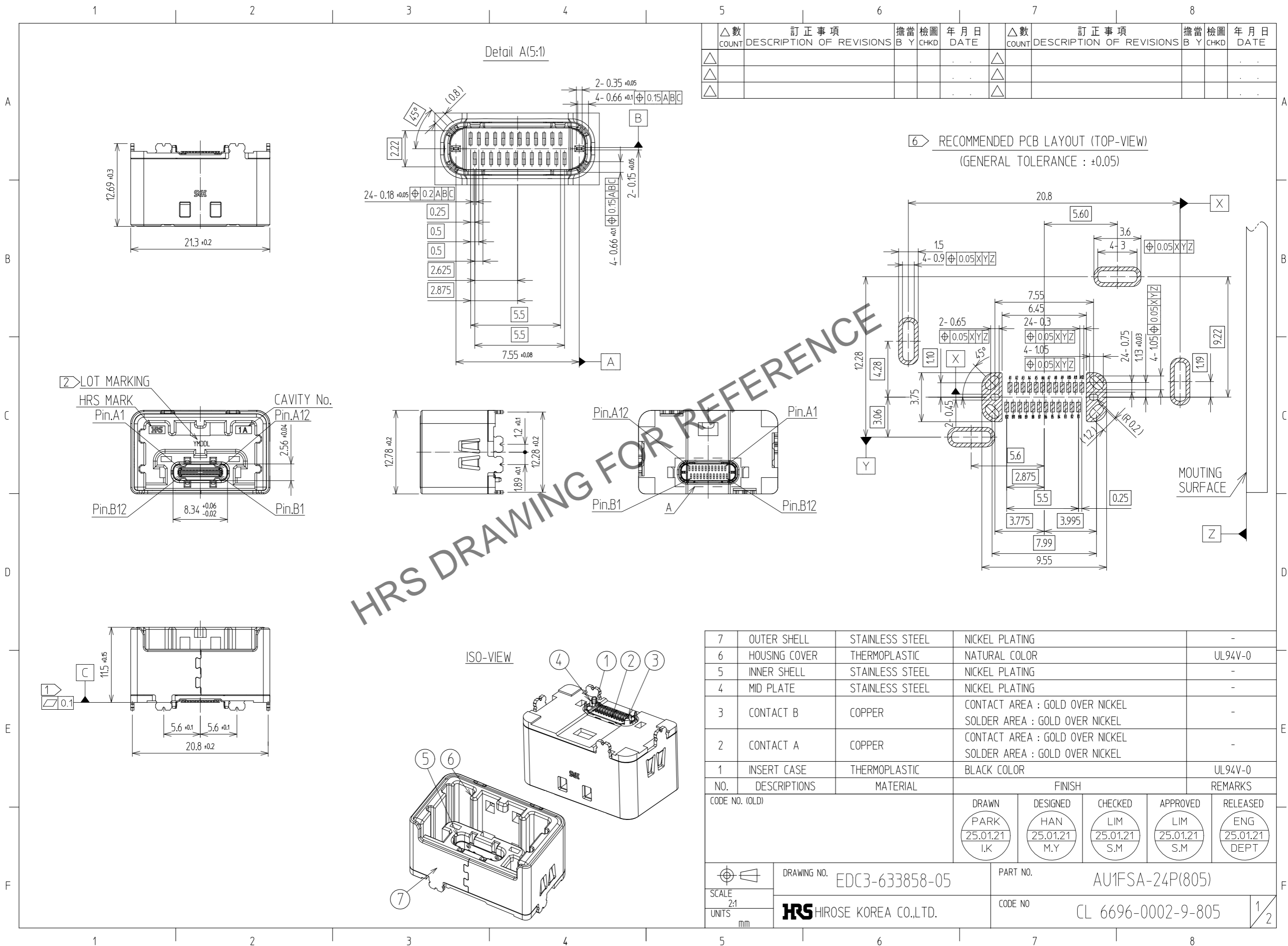

△數 COUNT	訂正事項 DESCRIPTION OF REVISIONS	擔當 B	檢圖 CHKD	年月日 DATE	△數 COUNT	訂正事項 DESCRIPTION OF REVISIONS	擔當 B	檢圖 CHKD	年月日 DATE

NO.	DESCRIPTIONS	MATERIAL	FINISH	REMARKS
7	OUTER SHELL	STAINLESS STEEL	NICKEL PLATING	-
6	HOUSING COVER	THERMOPLASTIC	NATURAL COLOR	UL94V-0
5	INNER SHELL	STAINLESS STEEL	NICKEL PLATING	-
4	MID PLATE	STAINLESS STEEL	NICKEL PLATING	-
3	CONTACT B	COPPER	CONTACT AREA : GOLD OVER NICKEL SOLDER AREA : GOLD OVER NICKEL	-
2	CONTACT A	COPPER	CONTACT AREA : GOLD OVER NICKEL SOLDER AREA : GOLD OVER NICKEL	-
1	INSERT CASE	THERMOPLASTIC	BLACK COLOR	UL94V-0

CODE NO. (OLD)	DRAWN PARK 25.01.21 I.K	DESIGNED HAN 25.01.21 M.Y	CHECKED LIM 25.01.21 S.M	APPROVED LIM 25.01.21 S.M	RELEASED ENG 25.01.21 DEPT
----------------	----------------------------------	------------------------------------	-----------------------------------	------------------------------------	-------------------------------------

SCALE 2:1 UNITS mm	DRAWING NO. EDC3-633858-05	PART NO. AU1FSA-24P(805)	CODE NO CL 6696-0002-9-805	1/2
-----------------------------	-------------------------------	-----------------------------	-------------------------------	-----

Feb.1.2026 Copyright 2026 HIROSE ELECTRIC CO., LTD. All Rights Reserved.
In case of consideration for using Automotive equipment / device which demand high reliability, kindly contact our sales window correspondents.

DRAWING FOR PACKING

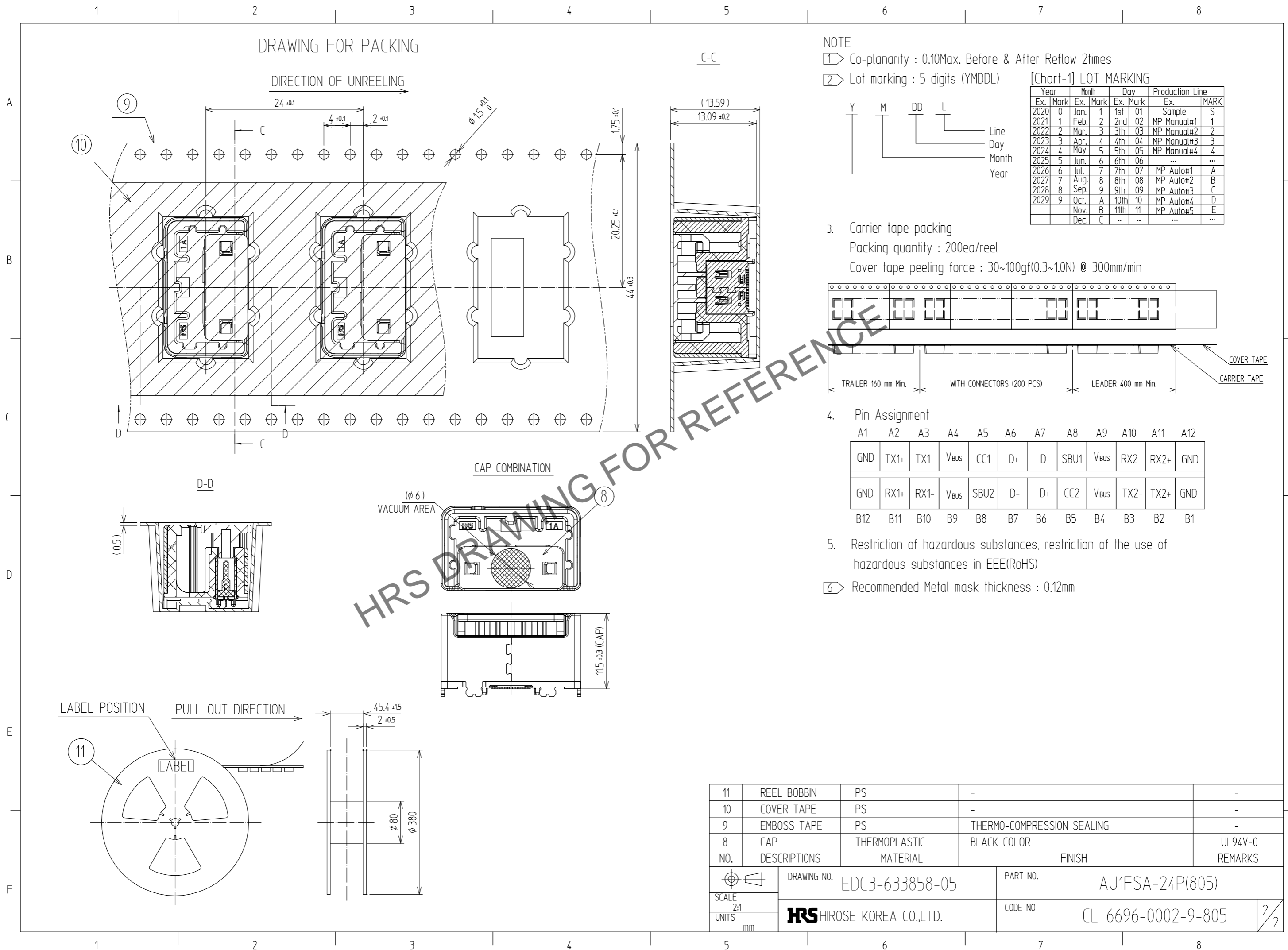

NOTE

- ① Co-planarity : 0.10Max. Before & After Reflow 2times
- ② Lot marking : 5 digits (YMDDL)

[Chart-1] LOT MARKING

Year	Month	Day	Production Line	Ex. Mark	MARK
2020	0	Jan. 1	1st 01	Sample	S
2021	1	Feb. 2	2nd 02	MP Manual#1	1
2022	2	Mar. 3	3th 03	MP Manual#2	2
2023	3	Apr. 4	4th 04	MP Manual#3	3
2024	4	May 5	5th 05	MP Manual#4	4
2025	5	Jun. 6	6th 06
2026	6	Jul. 7	7th 07	MP Auto#1	A
2027	7	Aug. 8	8th 08	MP Auto#2	B
2028	8	Sep. 9	9th 09	MP Auto#3	C
2029	9	Oct. A	10th 10	MP Auto#4	D
		Nov. B	11th 11	MP Auto#5	E
		Dec. C

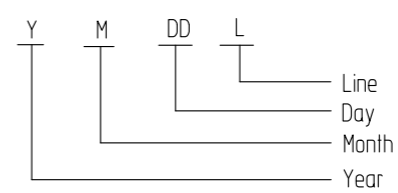

- 3. Carrier tape packing
Packing quantity : 200ea/reel
Cover tape peeling force : 30~100gf(0.3~1.0N) @ 300mm/min

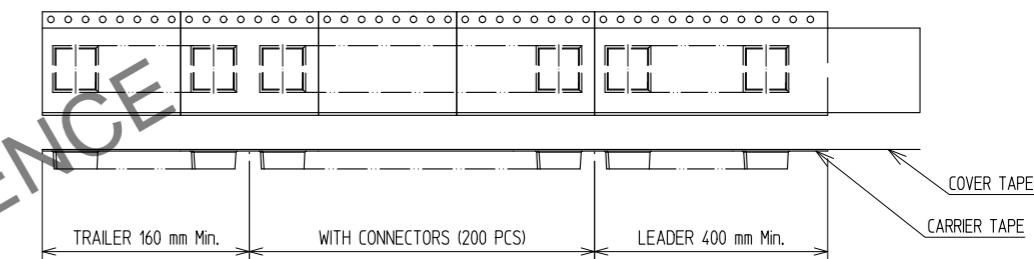

4. Pin Assignment

A1	A2	A3	A4	A5	A6	A7	A8	A9	A10	A11	A12
GND	TX1+	TX1-	V _{bus}	CC1	D+	D-	SBU1	V _{bus}	RX2-	RX2+	GND
GND	RX1+	RX1-	V _{bus}	SBU2	D-	D+	CC2	V _{bus}	TX2-	TX2+	GND
B12	B11	B10	B9	B8	B7	B6	B5	B4	B3	B2	B1

- 5. Restriction of hazardous substances, restriction of the use of hazardous substances in EEE(RoHS)

⑥ Recommended Metal mask thickness : 0.12mm

11	REEL BOBBIN	PS	-	-
10	COVER TAPE	PS	-	-
9	EMBOSS TAPE	PS	THERMO-COMPRESSION SEALING	-
8	CAP	THERMOPLASTIC	BLACK COLOR	UL94V-0
NO.	DESCRIPTIONS	MATERIAL	FINISH	REMARKS
DRAWING NO. EDC3-633858-05		PART NO. AU1FSA-24P(805)		
SCALE 2:1		CODE NO. CL 6696-0002-9-805		2/2
UNITS mm		HRS HIROSE KOREA CO.,LTD.		