

1.Scope

This document specifies the procedures of mating/unmating operation for DF51 series. It also includes the procedure for fixing In-line plug and In-line adapter to the panel.

This document contains general guidelines and operating suggestions to use this part safely. Unexpected troubles such as connector breakage could happen, if this product is used in other ways. Please read through this document and understand proper operation before use.

2.Connectors

Part No.	Description
DF51-*P(DP)-2DS(A)	Header
DF51-*EP(DEP)-2C	In-line plug
DF51B-*EP-2A	Branch adapter
DF51B-*/*EP-2A-#PRT	
DF51-*S(DS)-2C	Crimp socket
DF11-####SC(F)A	Crimp contact for socket
DF11-####PC(F)A	Crimp contact for relay connection plug

△3

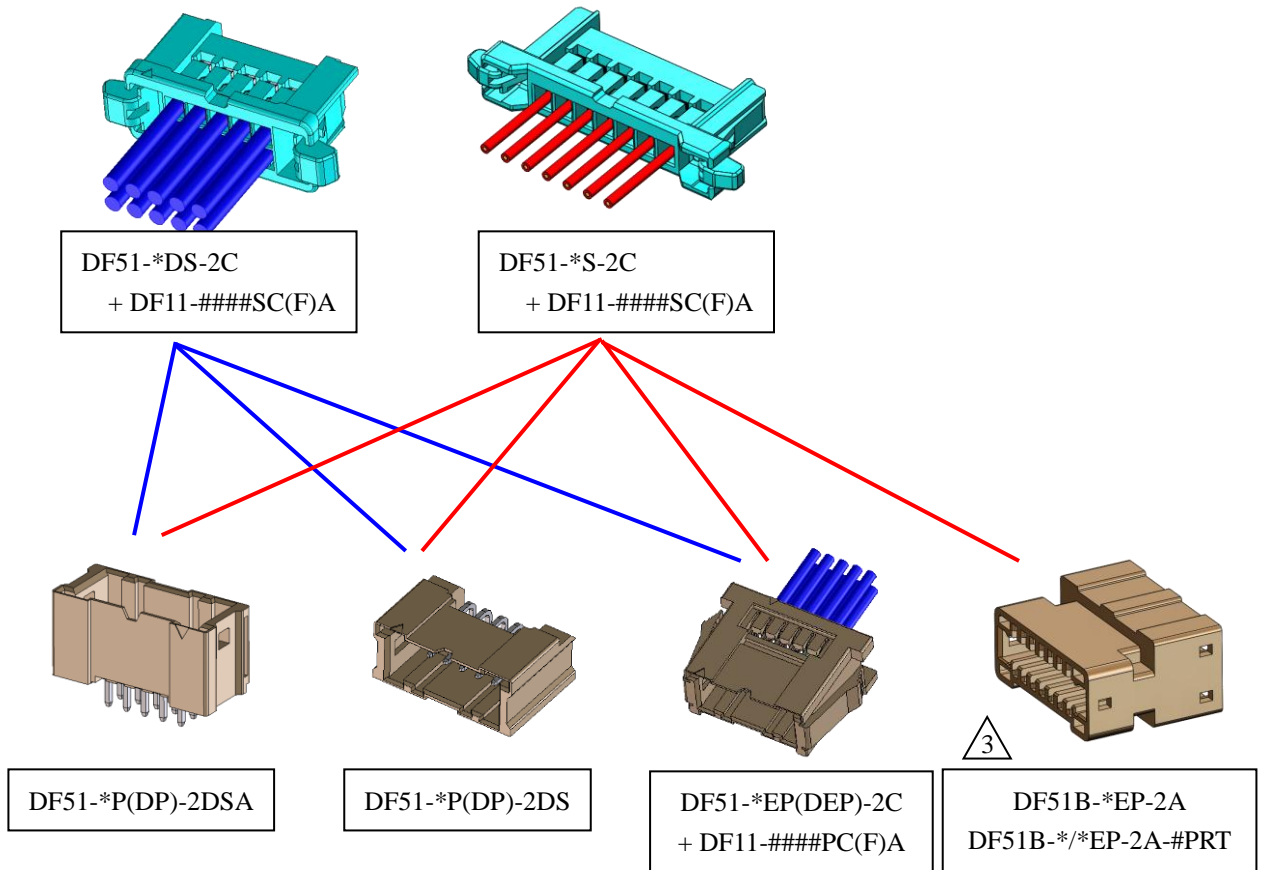



Fig. 1: DF51 series

COUNT	DESCRIPTION OF REVISIONS	DESIGNED	CHECKED	DATE
4	DIS-H-00021505	SN.MIWA	TT.OHSAKO	20241008
TITLE		 HIROSE ELECTRIC CO., LTD.		
DF51 Series Mating/Unmating Operation Instruction Manual		APPROVED	KI.AKIYAMA	20160113
		CHECKED	YN.TAKASHITA	20160113
		DESIGNED	TT.OHSAKO	20160113
		WRITTEN	TT.OHSAKO	20160113
TECHNICAL SPECIFICATION		ETAD-H0847-00		△3 1 / 8

3.Operation Procedure

3-1. Mating

3-1-a. Positioning for Insertion

: Position the crimp socket with the header or plug for relay connection according to the mating point mark.

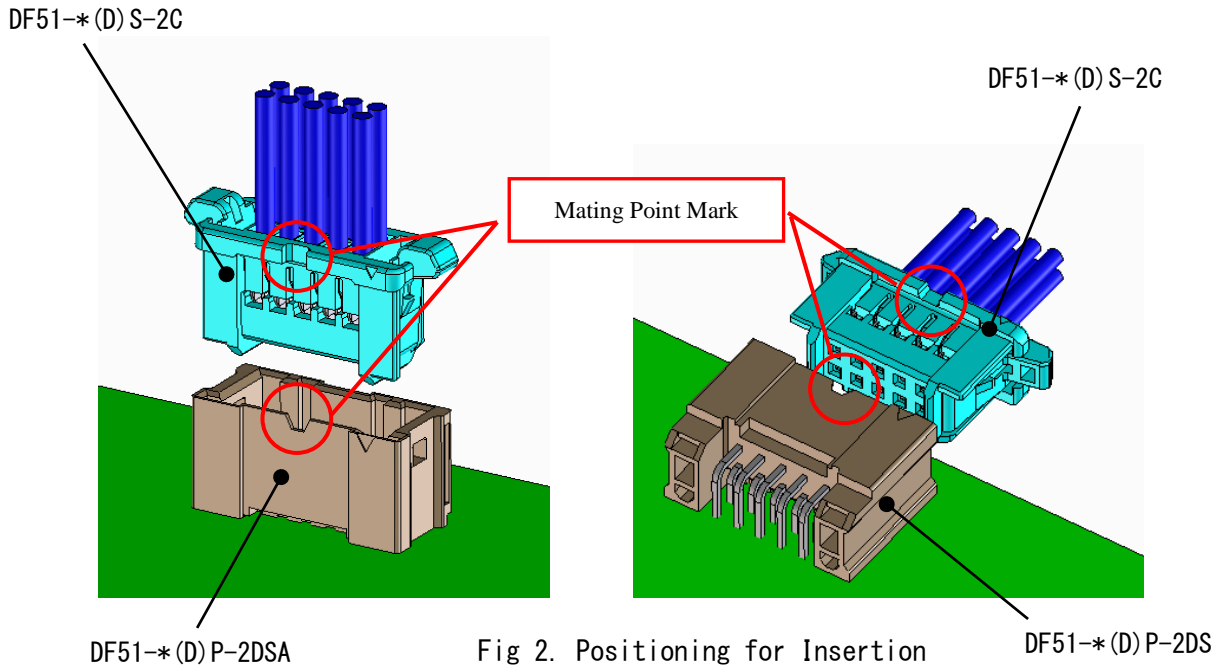

※Since DF51B series has no insertion direction mark, please align it in the direction shown in the figure below.

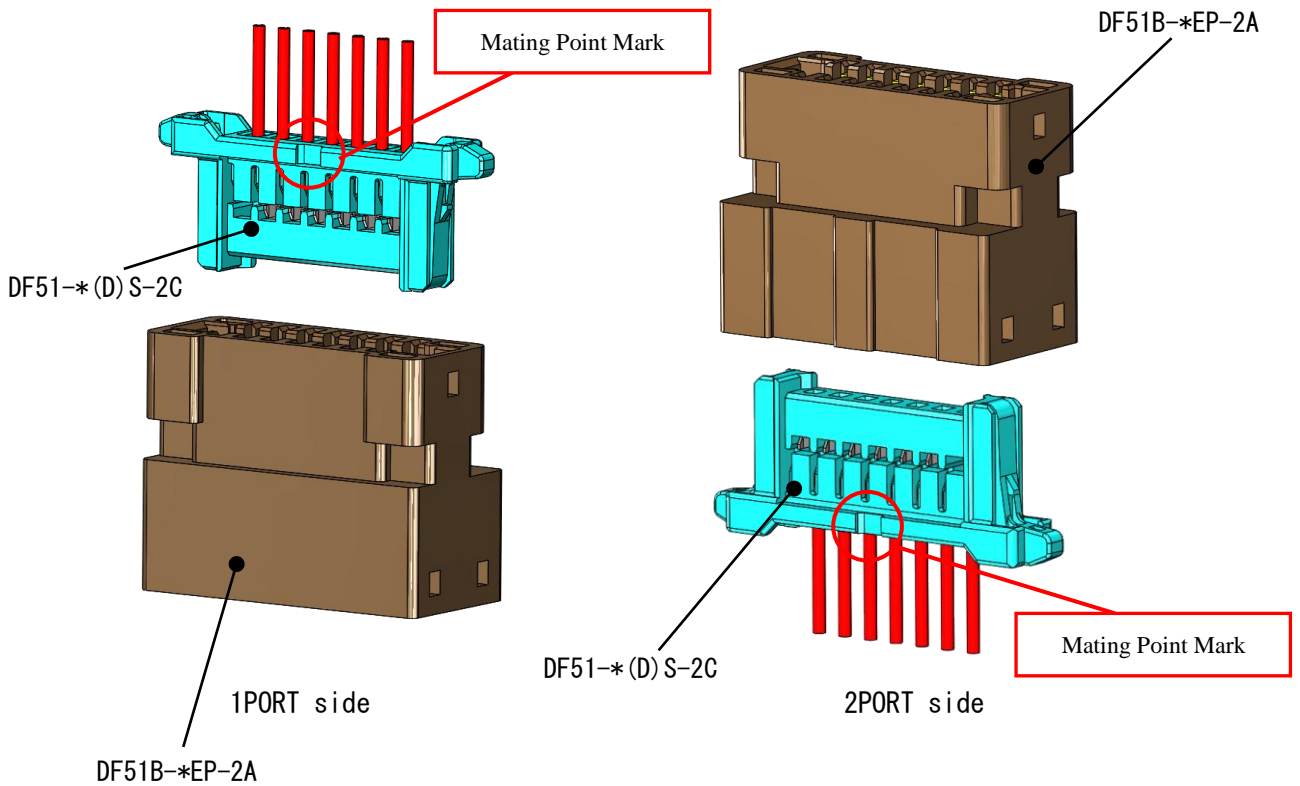

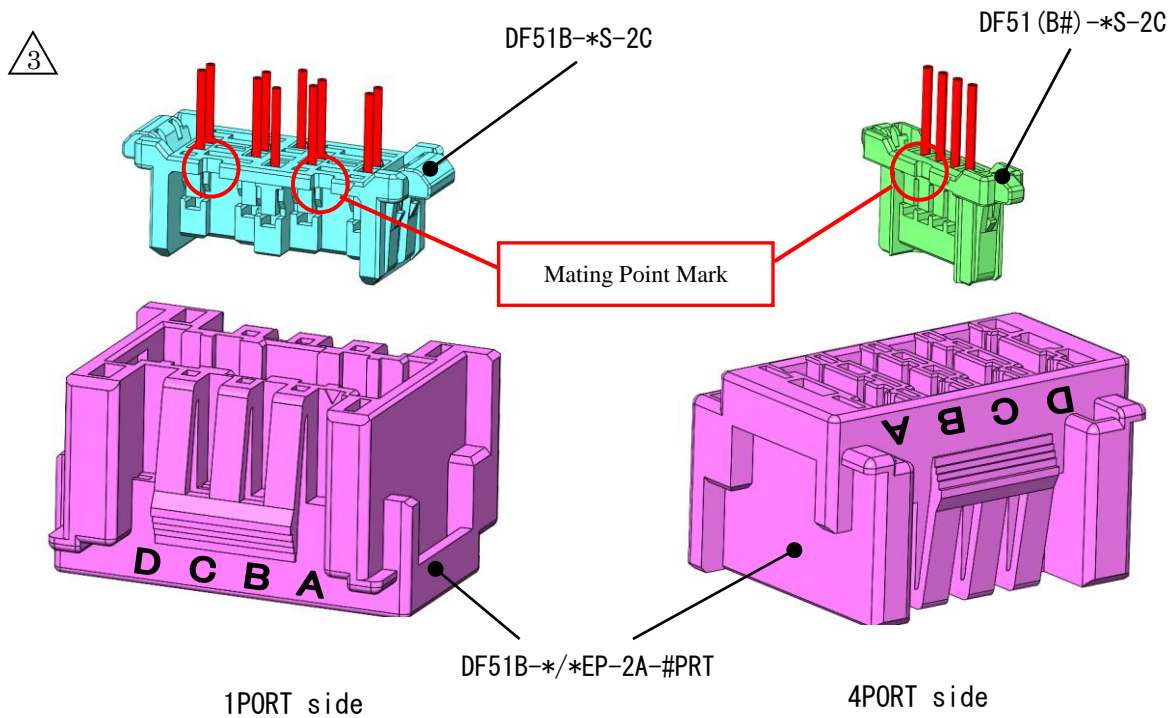

Fig 3. Positioning for Insertion(DF51B)

3-1-b. Insertion and Mating

: Insert the connector until it clicks.

* Please do not press the latches while insertion.

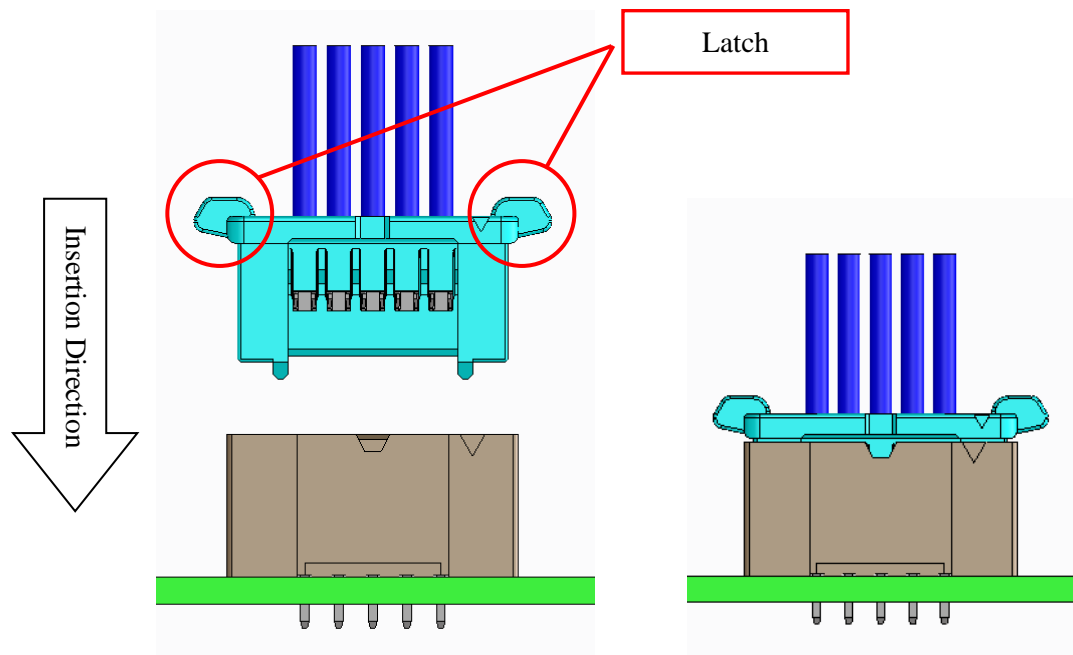

Fig 4. Insertion and Mating

Notice 1 : Do not tilt the socket in insertion as shown below in order to avoid negative influence on quality.

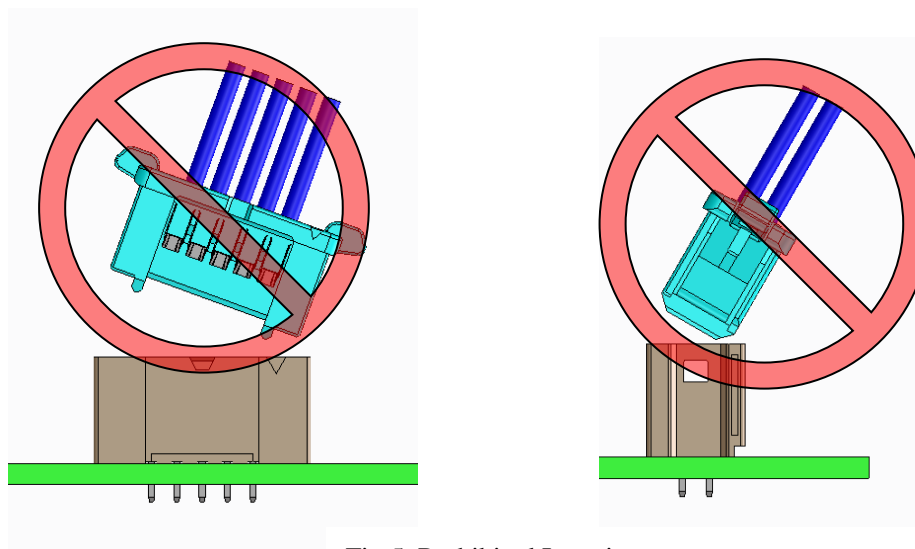

Fig 5. Prohibited Insertion

3-1-c. Confirmation of Mating

: Make sure that the crimp socket is completely mated.

(Make sure if the hooks are caught or not either by looking or by slightly pulling the cables by hand)

See 3-2. Unmating for removal

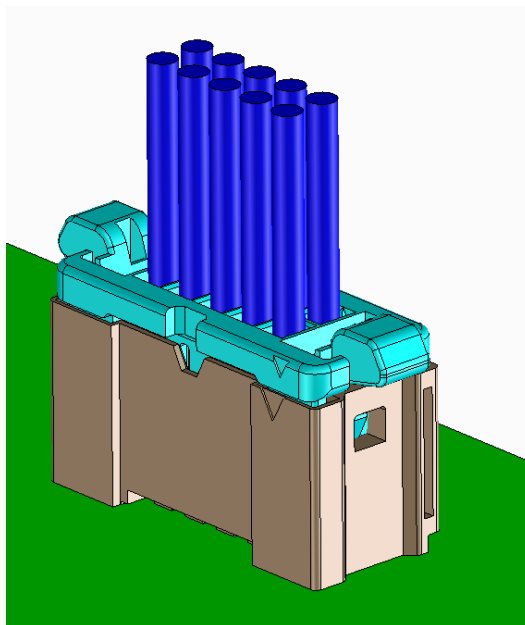

Fig 6. Mating Condition

3-2. Unmating

3-2-a. Grabbing cables

: Grab and hold all cables firmly



Fig 7. Grabbing Cables Condition

3-2-b. Removal

While having the cables, unlock the hooks by pressing the latches and pull the connector vertically

Note: the appropriate unmating cannot be done if the hooks are still stuck.

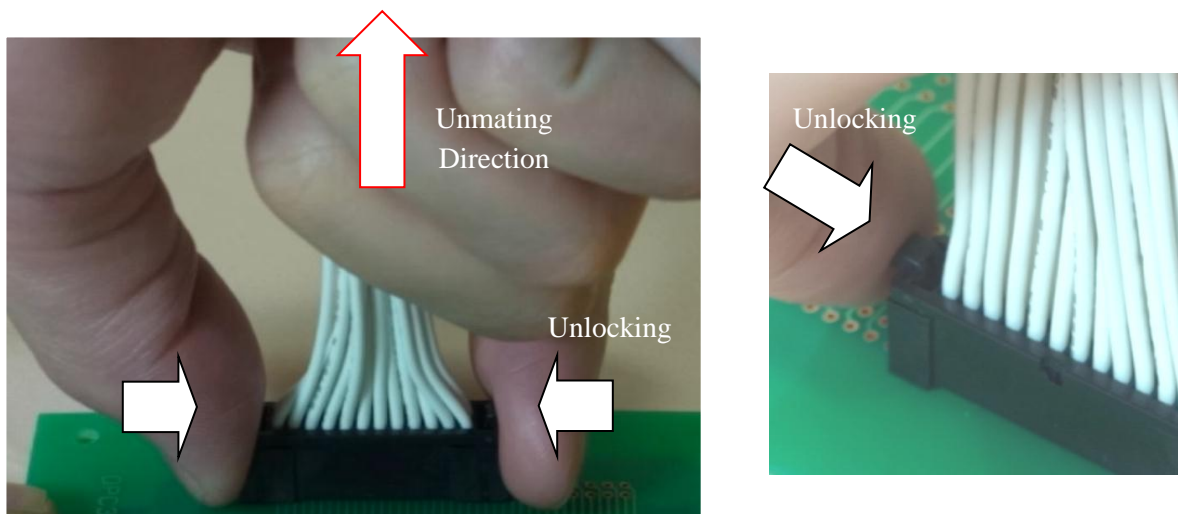

Fig 8. The way of Unmating

4.Precautions

- Do not insert or remove the socket while electrifying.
- Excessive external force to the connectors could cause fault and/or damage.
Therefore, avoid forced mating/unmating, impact given by dropping, or forced pulling the cables.

5. Other work procedures

5-1. Fixing of In-line plug and In-line adapter to the panel

5-1-a. Position for insertion

: Align the In-line plug or In-line adapter with the panel in the orientation shown below. Insert the In-line plug or In-line adapter into the panel in the direction shown in the figure below.

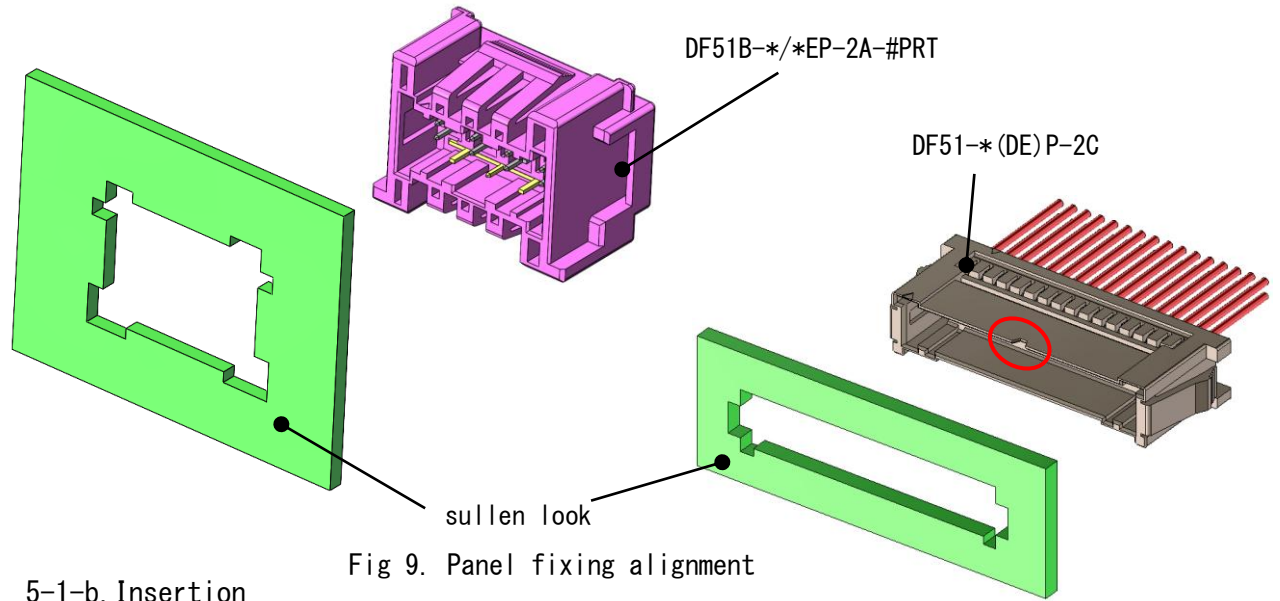

5-1-b. Insertion

: Insert the connector until it clicks.
 * Please do not press the latches while insertion.

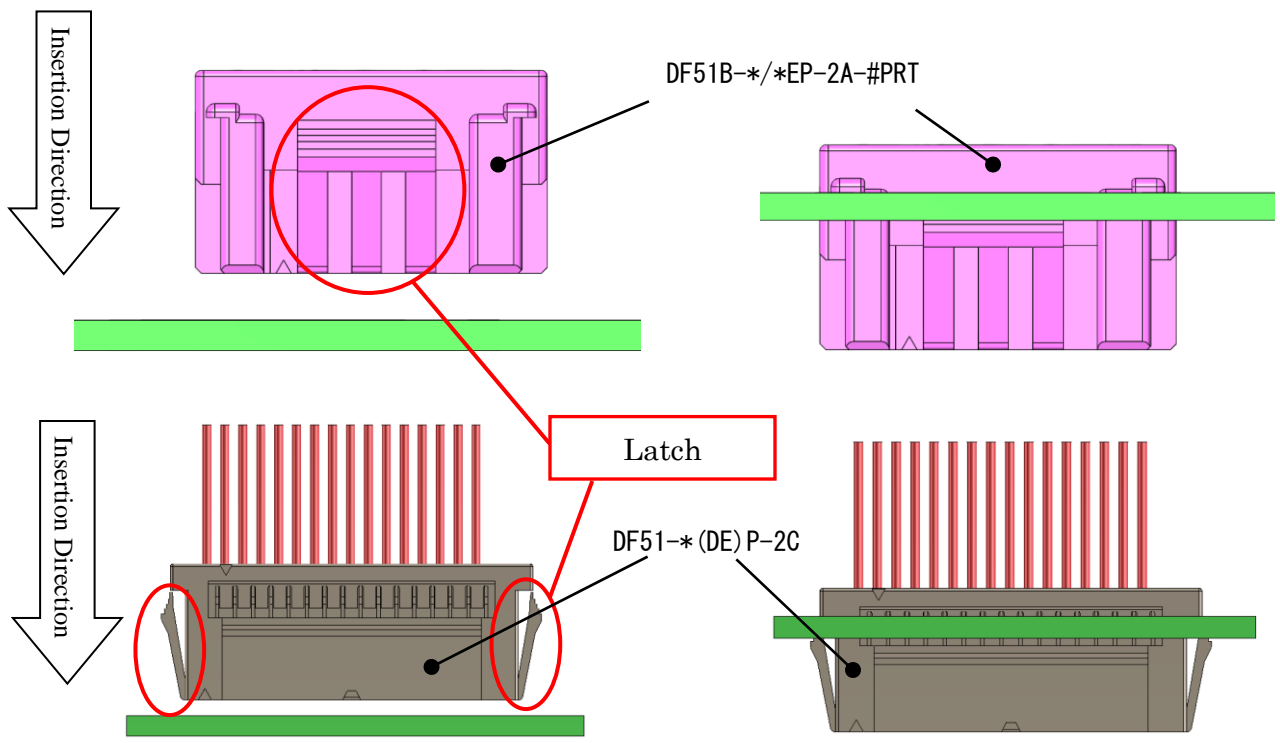

5-1-c. Fitting check

: Make sure that the In-line plug or In-line branch adapter is securely fixed to the panel.

(Check that the lock is caught on the panel visually or by grasping the cable or case and pulling lightly.)