

1. Scope

This document specifies the steps from crimping the DF62-series crimped terminals to cables (AWG22 ~ AWG30) to inserting the terminals to crimping sockets.

2. Connectors

■ Crimping cases

DF62 - * EP - 2.2 C

① ② ③ ④ ⑤

| | |
|---|---|
| ① | Name: DF62 |
| ② | No. of poles: 2 ~ 24 |
| ③ | Connector types S : Socket EP: In-line plug |
| ④ | Contact pitch: 2.2 mm |
| ⑤ | Shape of connection/terminal C: Crimping case |

■ Crimped terminals

DF62 - EP 2428 PCF A

① ② ③ ④

| | |
|---|---|
| ① | Application EP: In-line |
| ② | Compatible cables 22 : AWG22 2428: AWG24 ~ 28 30 : AWG30 |
| ③ | Shape/packing SCF : Socket terminal, reeled SC : Socket terminal, separate PCF : Plug terminal, reeled PC : Plug terminal, separate |
| ④ | Plating A : Gold plating Blank : Tin plating |

3. Steps for harnessing

3.1. Cable stripping

Strip cables in accordance with Crimping Quality Standards (ATAD-H0642/0643).
In so doing, make sure there is no scratch on cable cores.

| | COUNT | DESCRIPTION OF REVISIONS | DESIGNED | CHECKED | DATE | |
|--------------------------------------|-------|--------------------------|--|---------|----------|----------|
| △3 | 1 | DIS-H-00018280 | SS.YAMASAKI | SZ.ONO | 20230522 | |
| TITLE | | |  HIROSE ELECTRIC CO.,LTD. | | | |
| DF62 Series Cable Assembly Procedure | | | | | | |
| APPROVED | | KI.AKIYAMA | | | | 20130423 |
| CHECKED | | HK.UMEHARA | | | | 20130423 |
| DESIGNED | | TS.KUMAZAWA | | | | 20130423 |
| WRITTEN | | TS.KUMAZAWA | 20130423 | | | |
| TECHICAL SPECIFICATION | | | ETAD-H0593 | | △3 1 / 5 | |

3.2. Crimping

Crimp terminals to cables using an applicator (AP105-DF62- * *), and check the crimping height and shape in accordance with the Table of crimping conditions and Crimping Quality Standards (ATAD-H0642/0643).

(* * = 22, 2428 or 30)

3.3. Insertion to crimping terminal sockets

Hold the cable of a crimped terminal, and insert it to each terminal hole of crimping sockets. (Insert the terminal in the direction of arrows below.)

*The figures show insertion to DF62B-2EP-2.2C and DF62B-2S-2.2C.

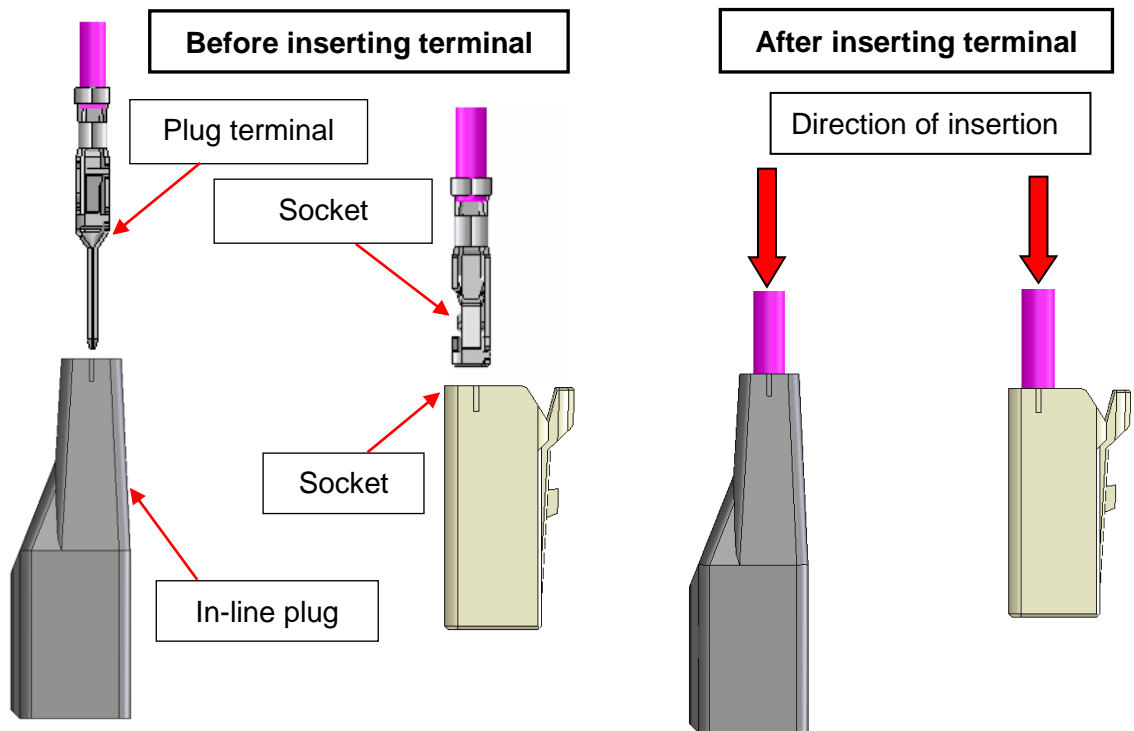

- For insertion, place the crimped terminal lance and crimping case lock in the following direction:

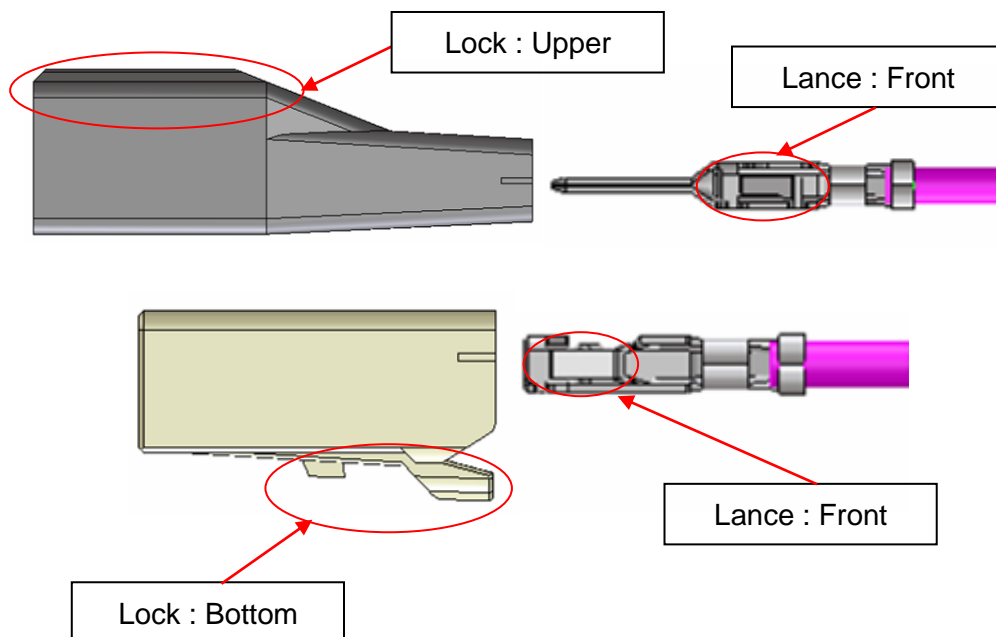

- See below for the terminal numbers of crimping cases:

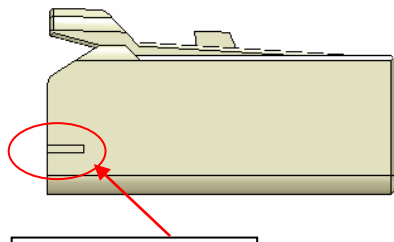

Terminal No.

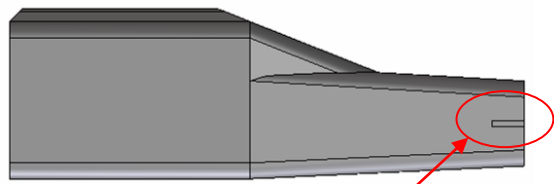

Terminal No.

terminal numbers (Common to socket and in-line plug)

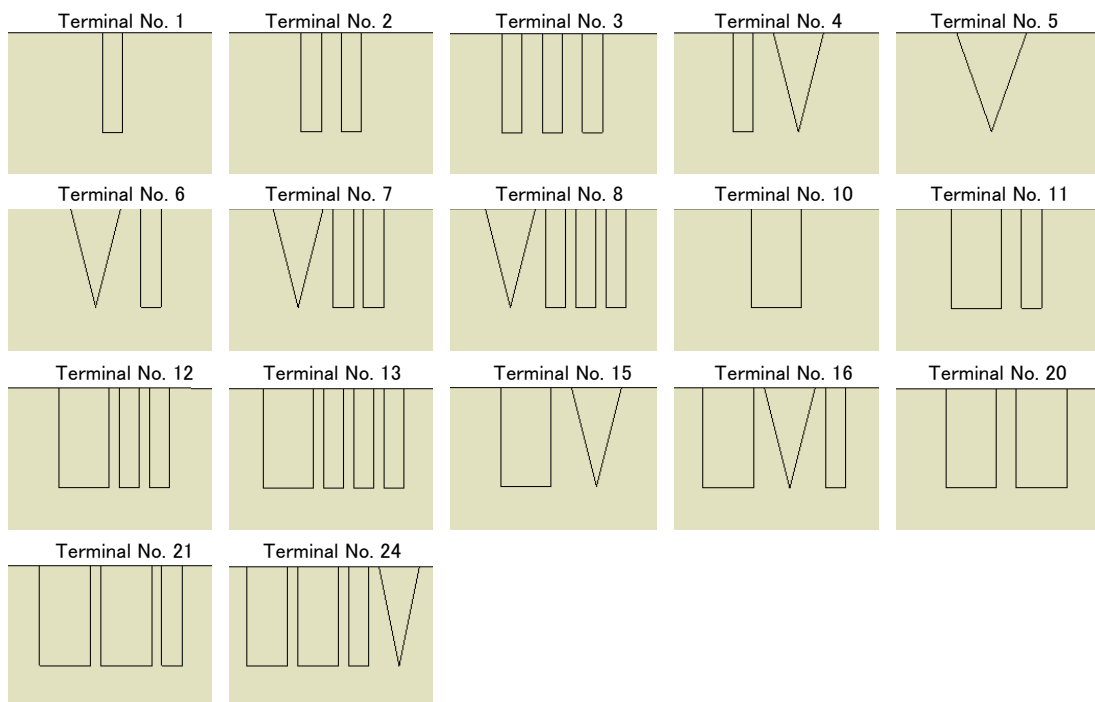

- To maintain performance reliability, do not tilt crimped terminals for insertion.

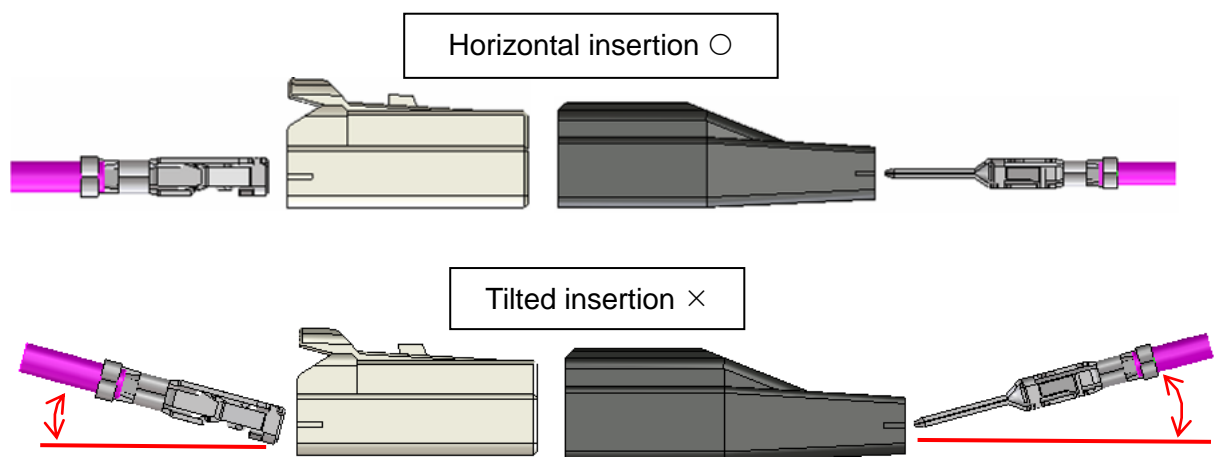

Horizontal insertion ○

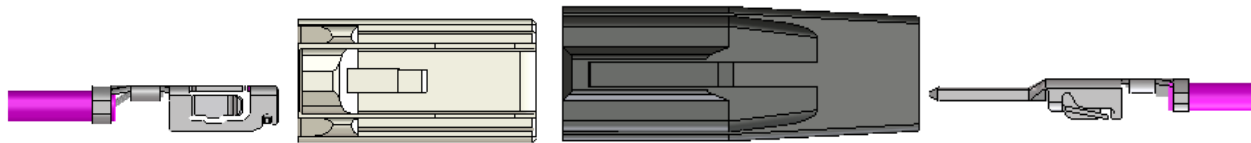

Tilted insertion ×



Check how terminals have been inserted

- Check that the lance of a crimped terminal has been caught at the lance holder of the crimping case.
(Slightly pull the terminal to check.)

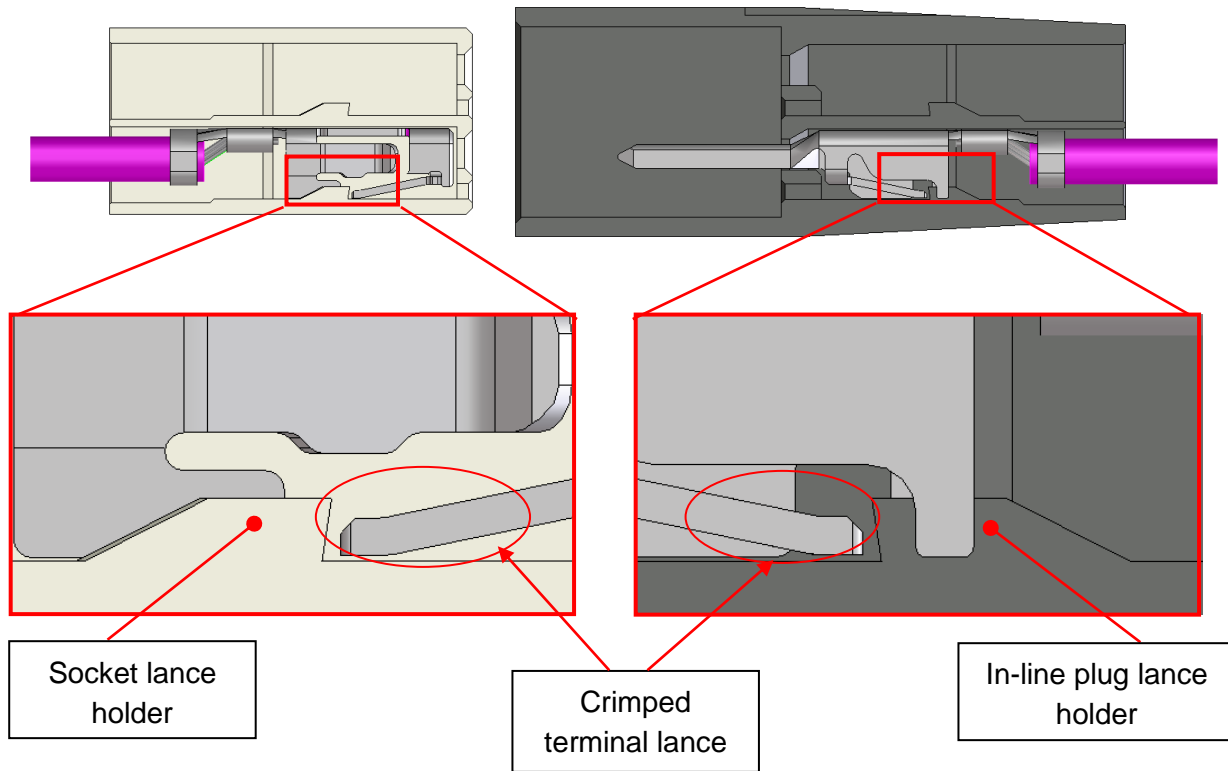

③ *Repair crimped terminals

To remove crimped terminals that have been inserted, pull the cable using the dedicated removing jig while pushing up the crimped terminal lance.

Repairing may have reduced the lance strength. Crimp terminals that have been repaired should not be reused, but new ones should be used. (The case can be reused.)

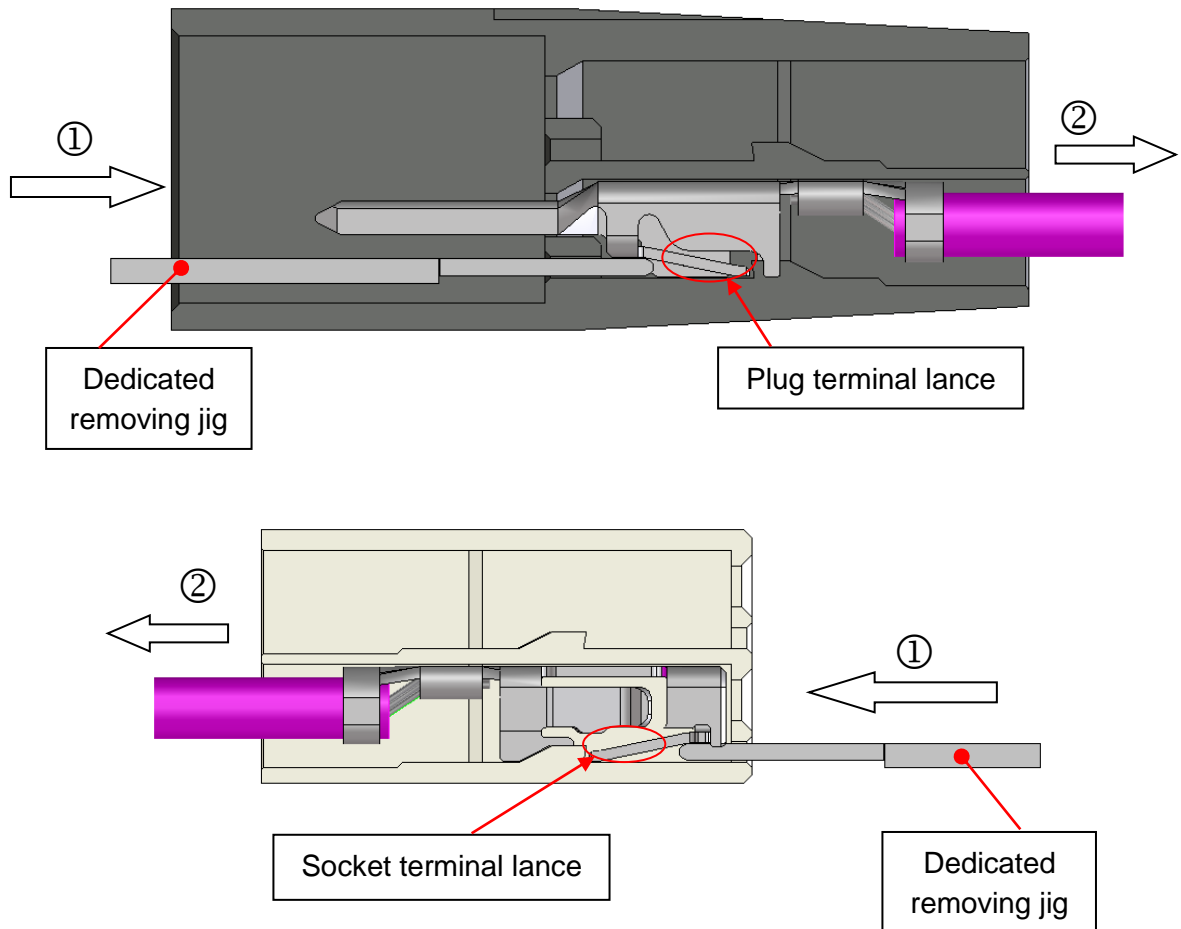

4. Precautions for handling

*Packing and storage

To pack or store assemblies, make sure overlapped connectors will not apply extreme load to the lock section.

If load is applied to the lock section under high temperature and humidity for a long period of time, the lock section will be deformed which could lead poor fitting.