

May.1.2024 Copyright 2024 HIROSE ELECTRIC CO., LTD. All Rights Reserved.
In case of consideration for using Automotive equipment / device which demand high reliability, kindly contact our sales window correspondents.

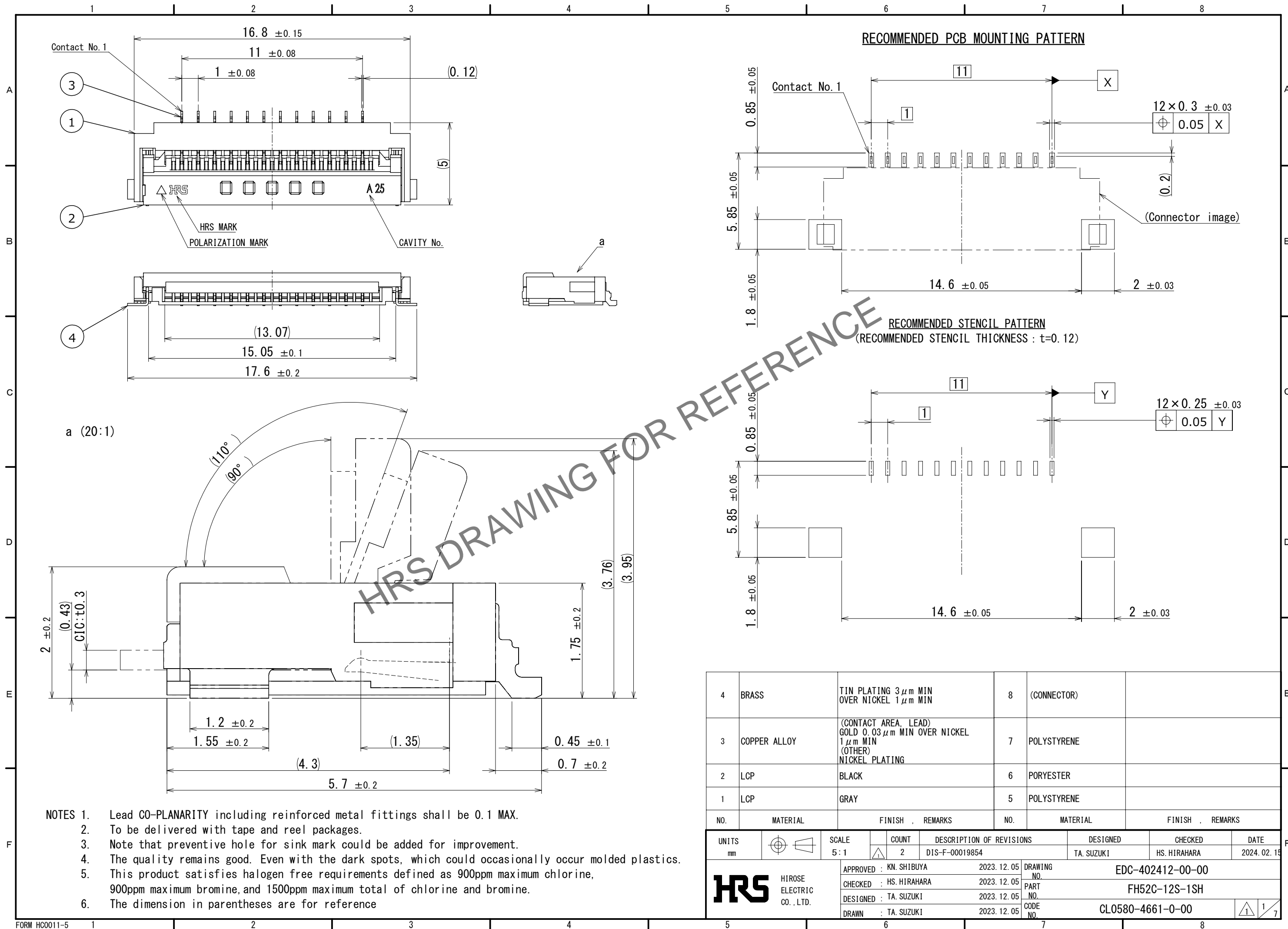

NO.	MATERIAL	FINISH	REMARKS	NO.	MATERIAL	FINISH	REMARKS
4	BRASS	TIN PLATING 3μm MIN OVER NICKEL 1μm MIN		8	(CONNECTOR)		
3	COPPER ALLOY	(CONTACT AREA, LEAD) GOLD 0.03μm MIN OVER NICKEL 1μm MIN (OTHER) NICKEL PLATING		7	POLYSTYRENE		
2	LCP	BLACK		6	PORYESTER		
1	LCP	GRAY		5	POLYSTYRENE		

UNITS	SCALE	COUNT	DESCRIPTION OF REVISIONS	DESIGNED	CHECKED	DATE
mm	5:1	2	DIS-F-00019854	TA. SUZUKI	HS. HIRAHARA	2024.02.15
APPROVED : KN. SHIBUYA			2023.12.05	DRAWING NO. EDC-402412-00-00		
CHECKED : HS. HIRAHARA			2023.12.05	PART NO. FH52C-12S-1SH		
DESIGNED : TA. SUZUKI			2023.12.05	CODE NO. CL0580-4661-0-00		
DRAWN : TA. SUZUKI			2023.12.05			

May.1.2024 Copyright 2024 HIROSE ELECTRIC CO., LTD. All Rights Reserved.
In case of consideration for using Automotive equipment / device which demand high reliability, kindly contact our sales window correspondents.

RECOMMENDED CIC (15:1)

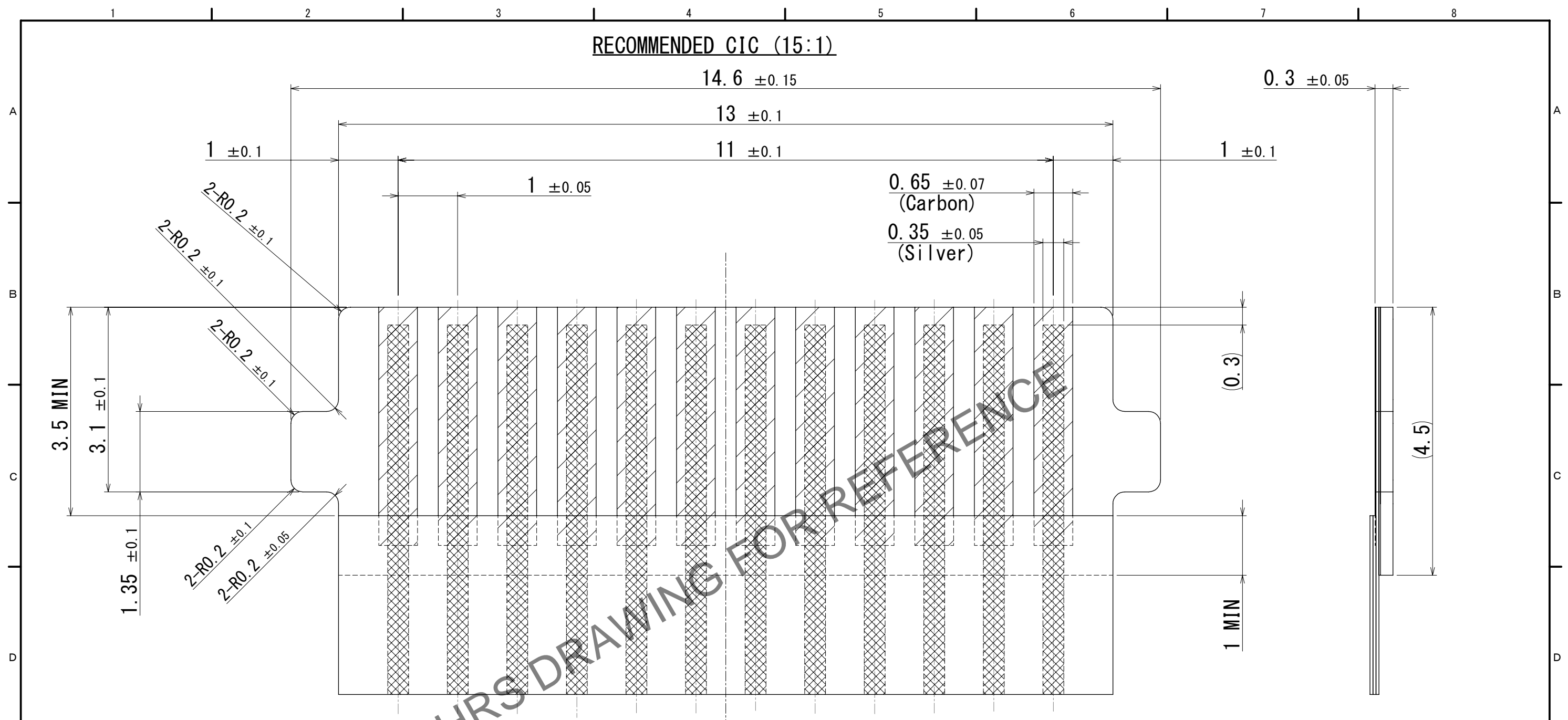

CIC CONFIGURATION (REFERENCE EXAMPLE)

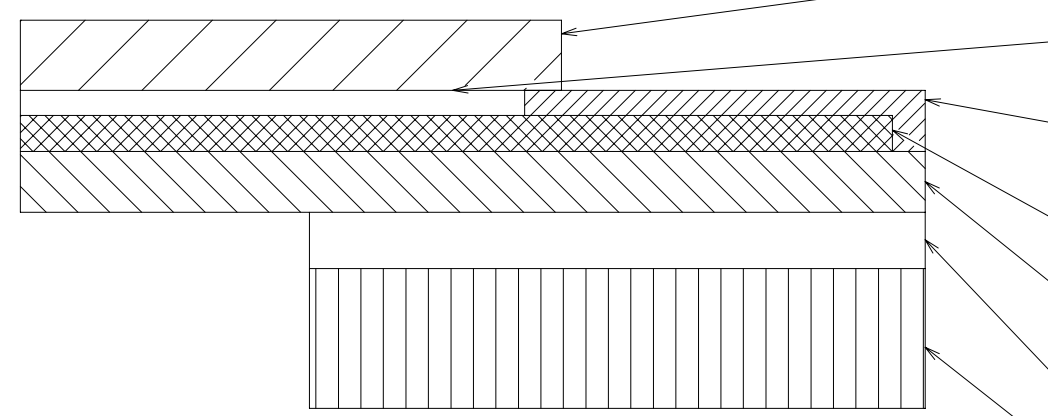

MATERIAL NAME	MATERIAL	THICKNESS (μm)
COVER FILM	PET	(50)
COVER ADHESIVE	ACRYLIC	(50)
CONDUCTIVE LINE	CARBON PENCIL HARDNESS:H OR MORE	5
CONDUCTIVE LINE	SILVER	10
BASE	PET	50
ADHESIVE	ACRYLIC	25
STIFFNER	PET	210

HRS	DRAWING NO.	EDC-402412-00-00
	PART NO.	FH52C-12S-1SH
	CODE NO.	CL0580-4661-0-00
	2/7	

May.1.2024 Copyright 2024 HIROSE ELECTRIC CO., LTD. All Rights Reserved.
 In case of consideration for using Automotive equipment / device which demand high reliability, kindly contact our sales window correspondents.

EMBOSSED CARRIER TAPE DIMENSION (2:1)

REEL DIMENSION (No Scale)

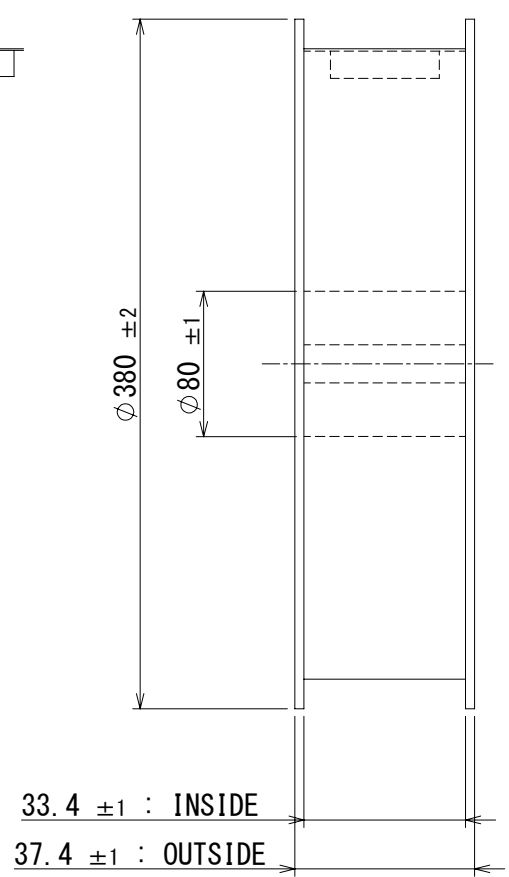
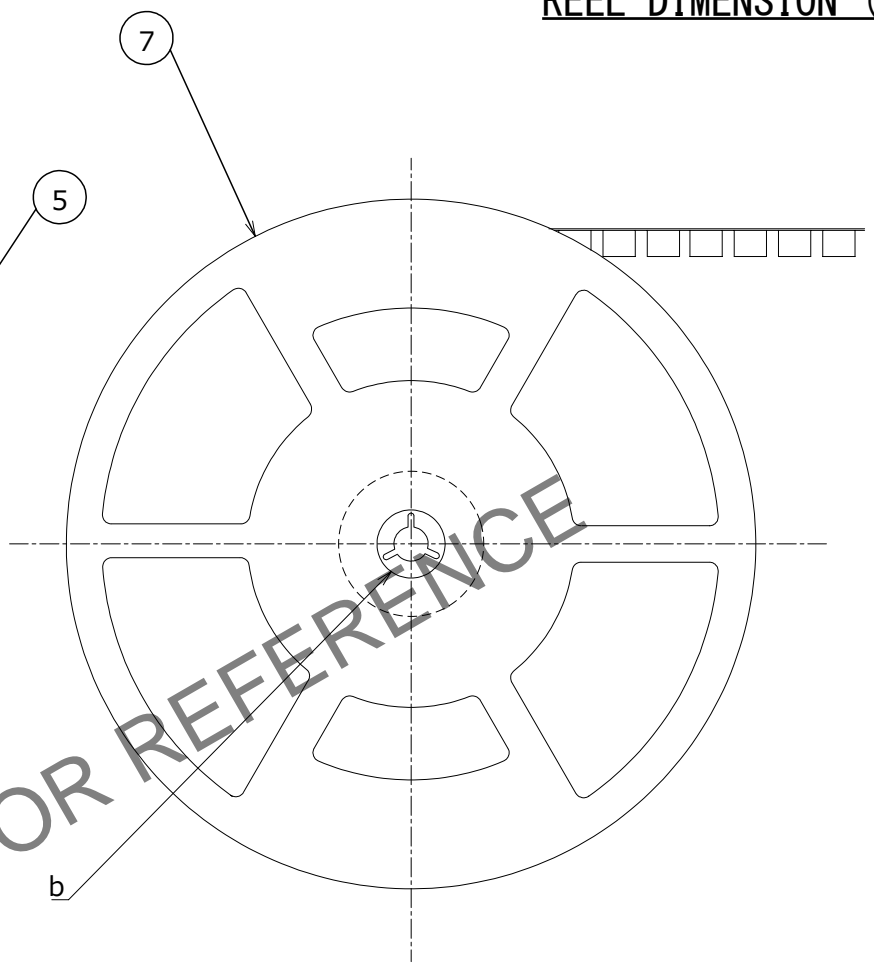
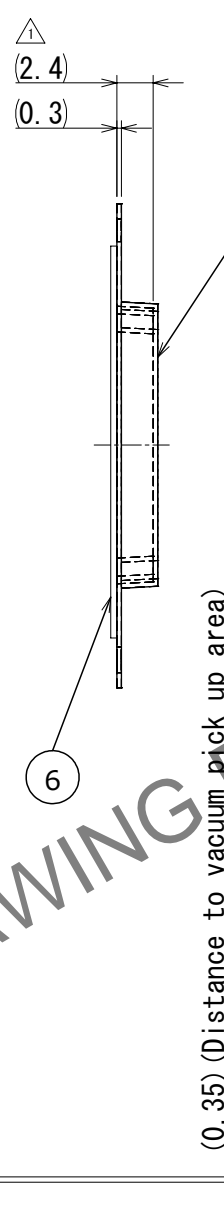
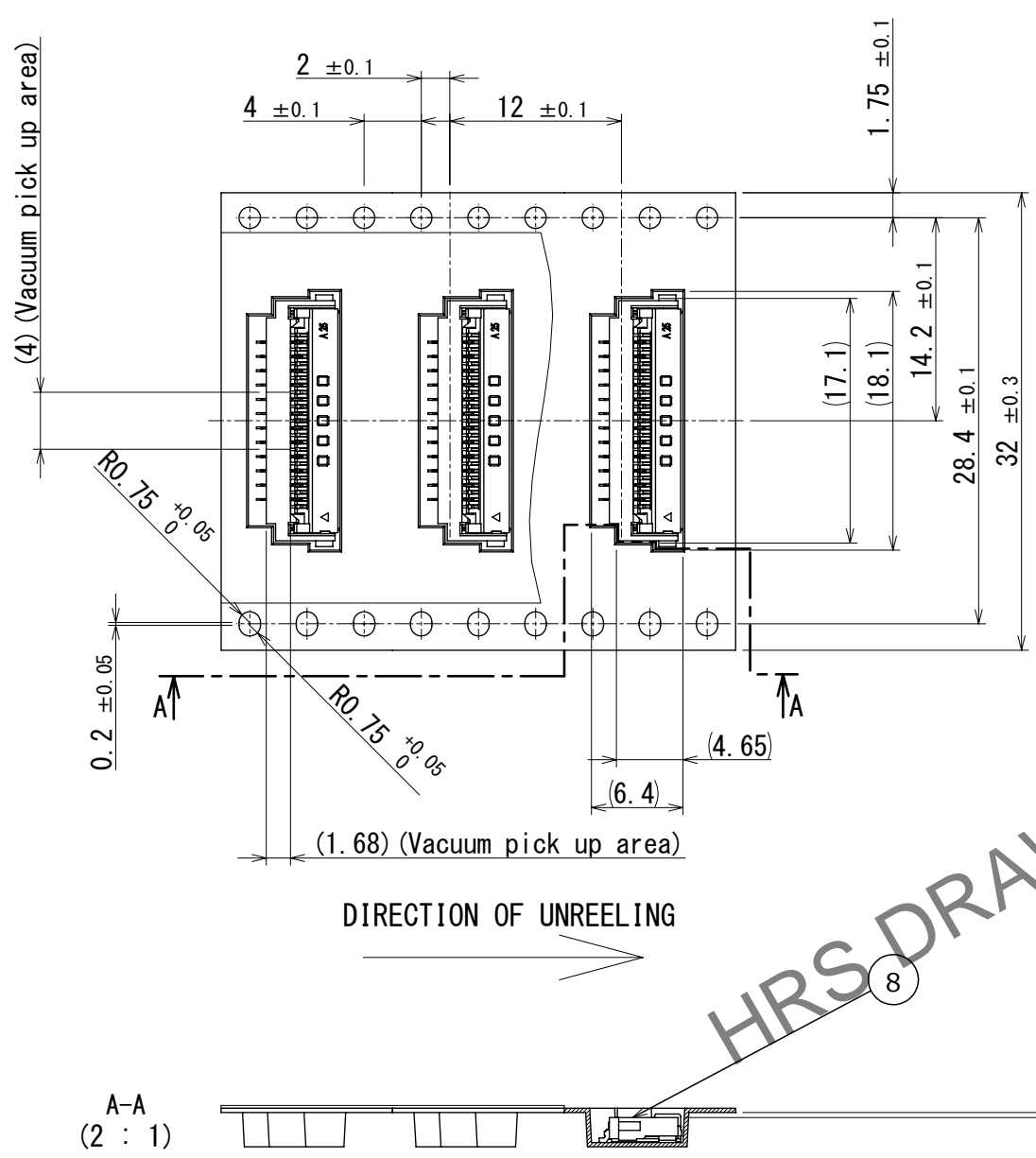

A-A
(2 : 1)

LEADER, TRAILER DIMENSION (FREE)

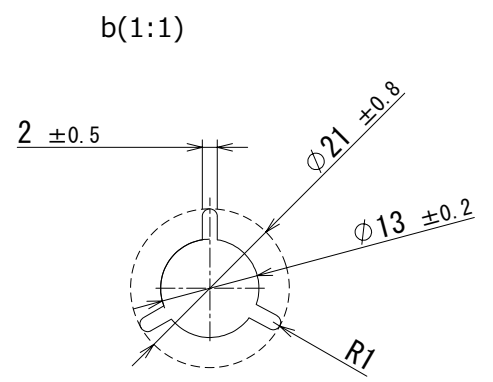
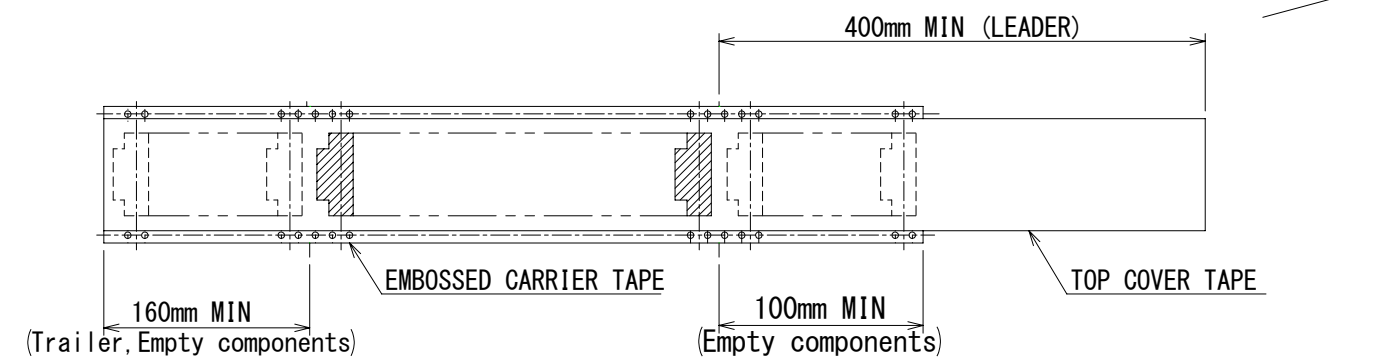

- Notes
 7. 1reel : 3000 connectors
 8. Refer to JIS C 0806 and IEC 60286-3. (Packing of components for automatic handling.)

HRS	DRAWING NO.	EDC-402412-00-00
	PART NO.	FH52C-12S-1SH
	CODE NO.	CL0580-4661-0-00
	3/7	

May.1.2024 Copyright 2024 HIROSE ELECTRIC CO., LTD. All Rights Reserved.
In case of consideration for using Automotive equipment / device which demand high reliability, kindly contact our sales window correspondents.

Indicates connector usage for a typical Front-flip structure.

To prevent connector/CIC breakage and contact failure (mating failure, CIC pattern breakage, etc), read through the instructions shown below and handle the connector properly. Although this instruction manual is applicable to usage with CIC.

2. How to lock and unlock

The actuator rotates around the rotational axis.

Lock : Apply load to rotate the actuator after inserting the CIC.

Unlock : Slowly flip up the actuator to release the lock.

【Connector Part Nomenclature】

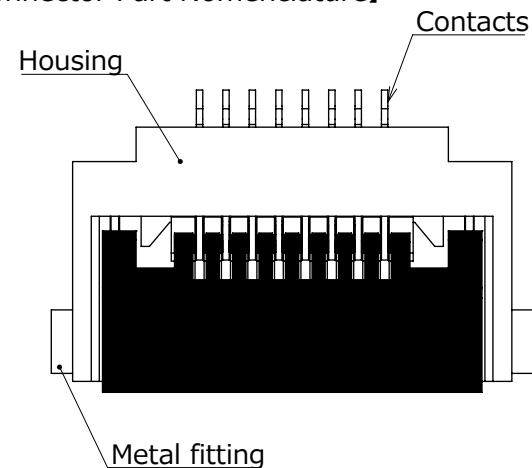

- Top view -

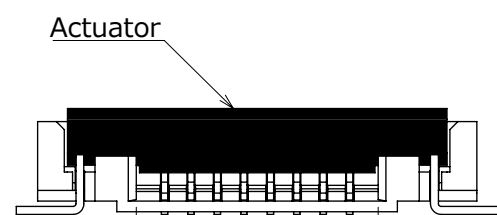

- Front view -

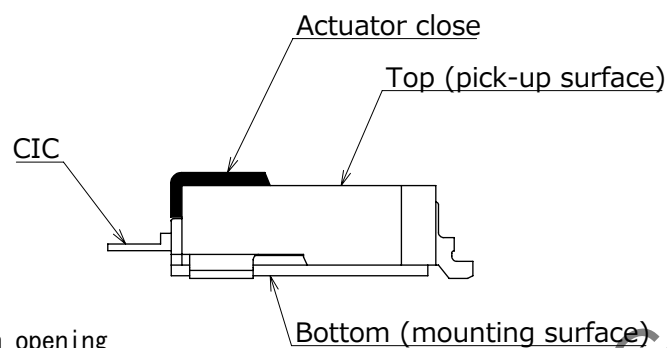
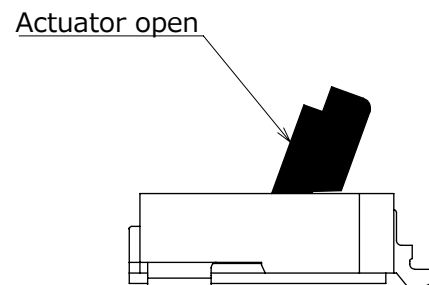

- Side view -

【Operation and cautions】

1. Initial condition

The connector is delivered with the actuator closed.

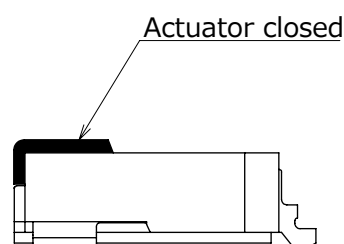

- When delivered -

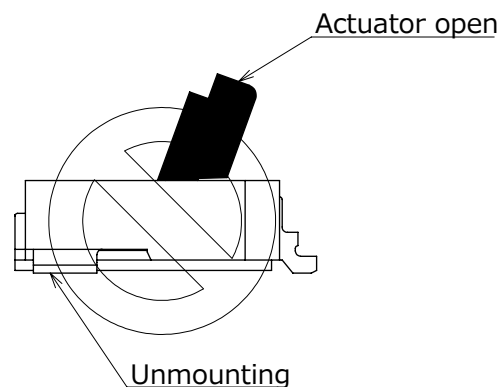

NG

Operate actuator unmounting

OK

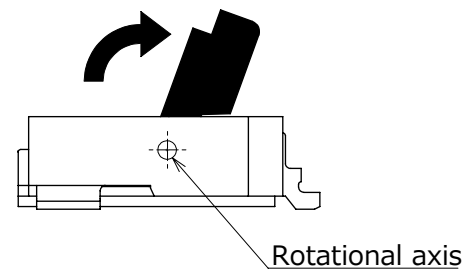

OK

Operate the center of the actuator

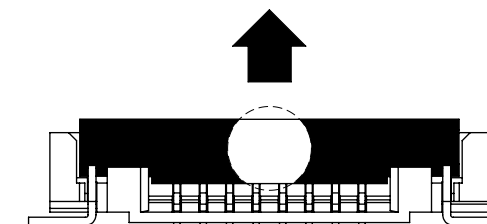

OK

Operate near both-ends of the actuator at the same timing moment.

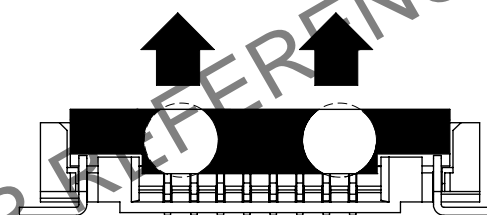

NG

Operate at one end of the actuator

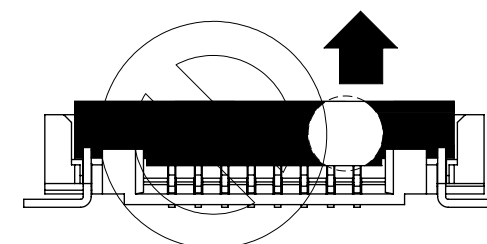

NG

Operation to push the actuator into connector

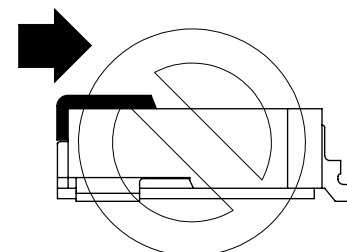

NG

Insertion of fingernails or any tool inside the connector

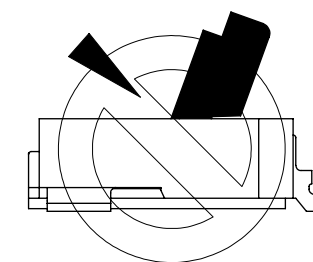

NG

Excessive load on actuator

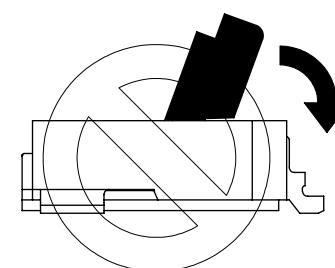

NG

Pick the actuator to lift

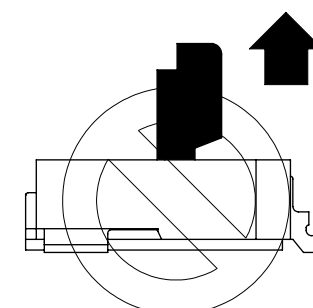

<Instruction manual(1)>

HRS	DRAWING NO.	EDC-402412-00-00
	PART NO.	FH52C-12S-1SH
	CODE NO.	CL0580-4661-0-00
	4/7	

May.1.2024 Copyright 2024 HIROSE ELECTRIC CO., LTD. All Rights Reserved.
In case of consideration for using Automotive equipment / device which demand high reliability, kindly contact our sales window correspondents.

3. How to insert and remove CIC

This connector has contacts on the bottom, insert the CIC with the exposed conductors face down.
This connector has boss for positioning CIC, insert the CIC at about 10 degree angle to the PCB mounting surface.
In case of using CIC without tabs, insert the CIC horizontally along the surface.
After rotating the actuator to the fully opened position carefully withdraw the CIC pulling out at about 10 degree angle to the PCB mounting surface.
In case of using CIC without tabs, pull out the CIC horizontally along the surface.

4. CIC insertion check and mating confirmation of the CIC

Boss for positioning CIC guide the CIC tabs to the correct position.
Make sure that the CIC tabs are located in correct position as shown in the figure below after CIC insertion.

OK

CIC (Proper position)

- When CIC insertion is completed -

- When actuator lock is completed -

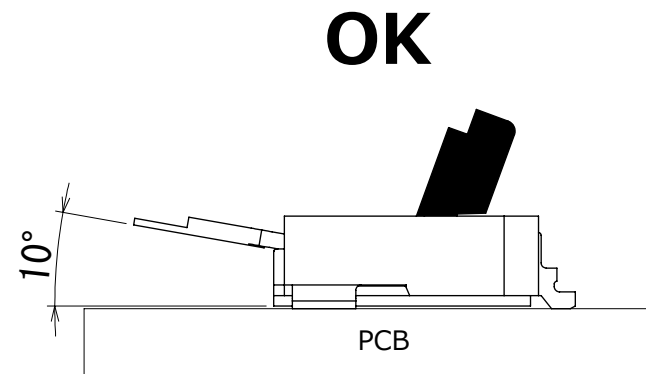

OK

NG
Insertion and removal excessive angles from PCB surface

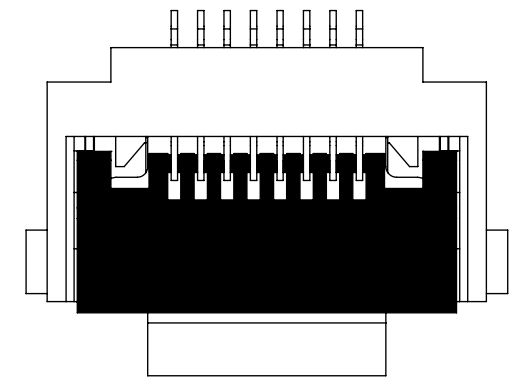
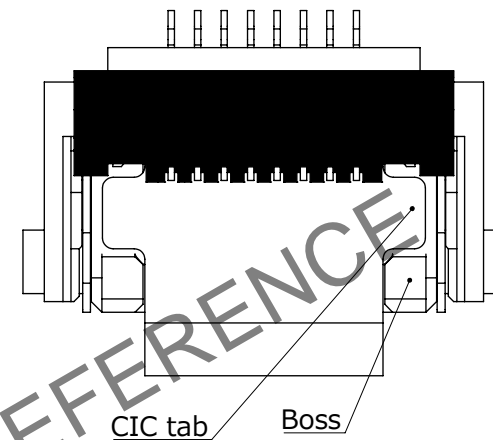
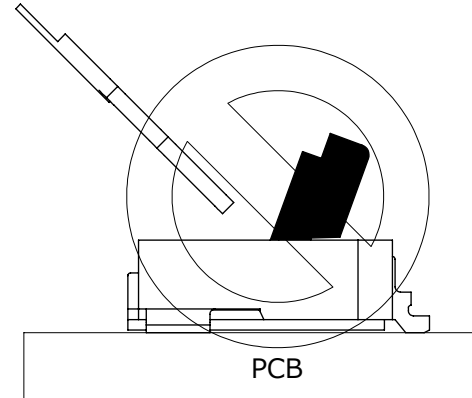

NG

CIC (Shallow position)

CIC (Slanted)

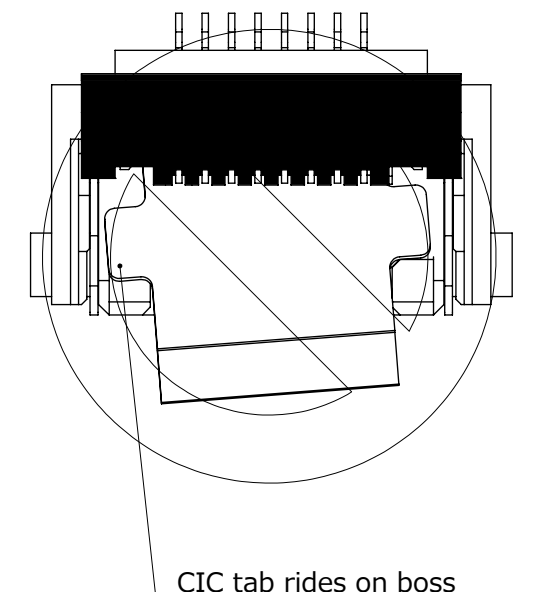
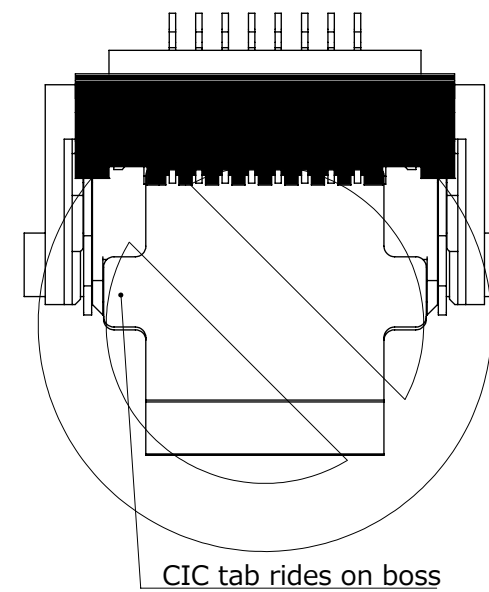

NG

Insertion and removal during wrenching up, down, left and right.

NG

Insertion and removal with actuator close

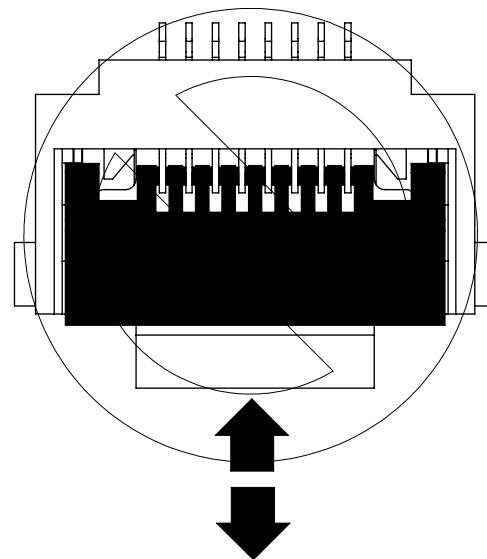
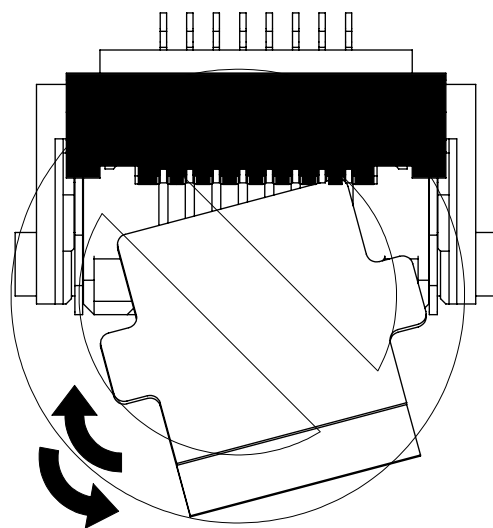

<Instruction manual(2)>

HRS	DRAWING NO.	EDC-402412-00-00	5/7
	PART NO.	FH52C-12S-1SH	
	CODE NO.	CL0580-4661-0-00	

May.1.2024 Copyright 2024 HIROSE ELECTRIC CO., LTD. All Rights Reserved.
In case of consideration for using Automotive equipment / device which demand high reliability, kindly contact our sales window correspondents.

[Instructions for PCB layout]

Please design a PCB layout not to apply load to connector and CIC.

[Cautions]

- If the CIC has to be curled/bended in your cabling design, please keep enough degree of freedom in your design to keep the CIC tension free. In this regard, the stiffener is parallel to the PCB.
- Do not mount other components underneath the CIC stiffener which may interfere with the connection.
- Please consult with the CIC manufacturer about CIC bending performance and wire breakage strength while making design.
- Keep enough space for the rotation of the actuator during PCB and component layout design.
- Please consult with our sales representative if you are using CIC with different configuration from our recommendation.

[Instructions for mounting on the PCB]

- Refer to recommended layouts for PCB, stencil pattern and CIC dimension. Please inspect the size of solder fillet and flux climbing height of the mounted connector while using different land/stencil pattern from our recommendation.
- Please verify your solder resist/silk screening design carefully before implementing the design.
- Apply reflow temperature profile within the specified conditions. For specific applications, the recommended temperature may vary depending on type/volume/thickness of solder paste and size/thickness of PCB. Please consult with your solder paste and equipment manufacturer for specific recommendations.
- Please try to minimize the warpage of the PCB. Soldering failure could still occur due to the PCB warpage even if the coplanarity of the connector is under 0.1mm.
- Do not apply 1N or greater external force on the connector when unreeling or handling the connector before mounting. Excessive mechanical stress may damage the connector before mounting.

[Instructions for PCB handling after mounting the connector]

The warpage of PCB may apply excessive stress on the connector and damage the connector.

- During the assembly processes described below, care shall be taken so as not to give any stresses of deflection or twisting to the PCB.
 - Splitting a large PCB into several pieces
 - Installing mounting screw on PCB

The warpage of a 100mm wide PCB should remain within 0.5mm.

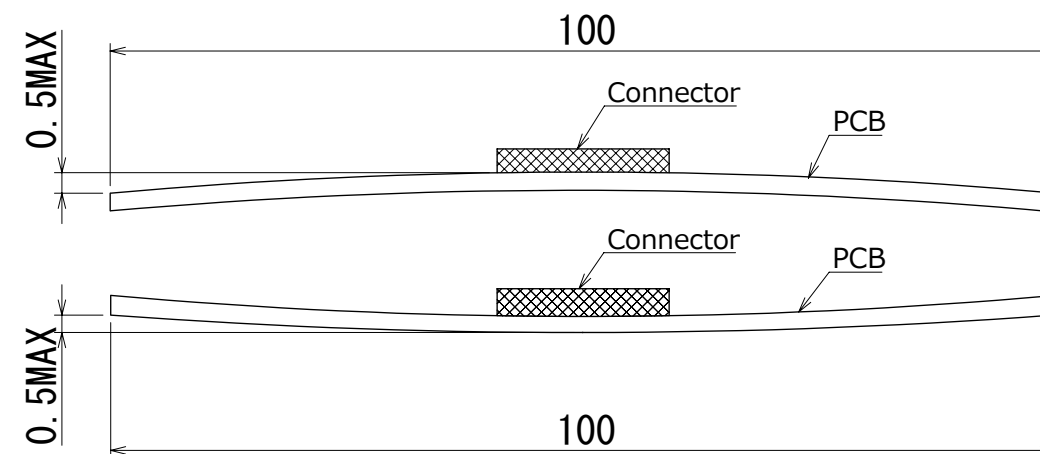

[Instructions of manual soldering]

- Do not perform hand soldering with the CIC inserted into the connector.
- Do not apply excessive heat. And soldering iron must not touch connector except terminal leads area.
- Do not supply excessive solder (flux).

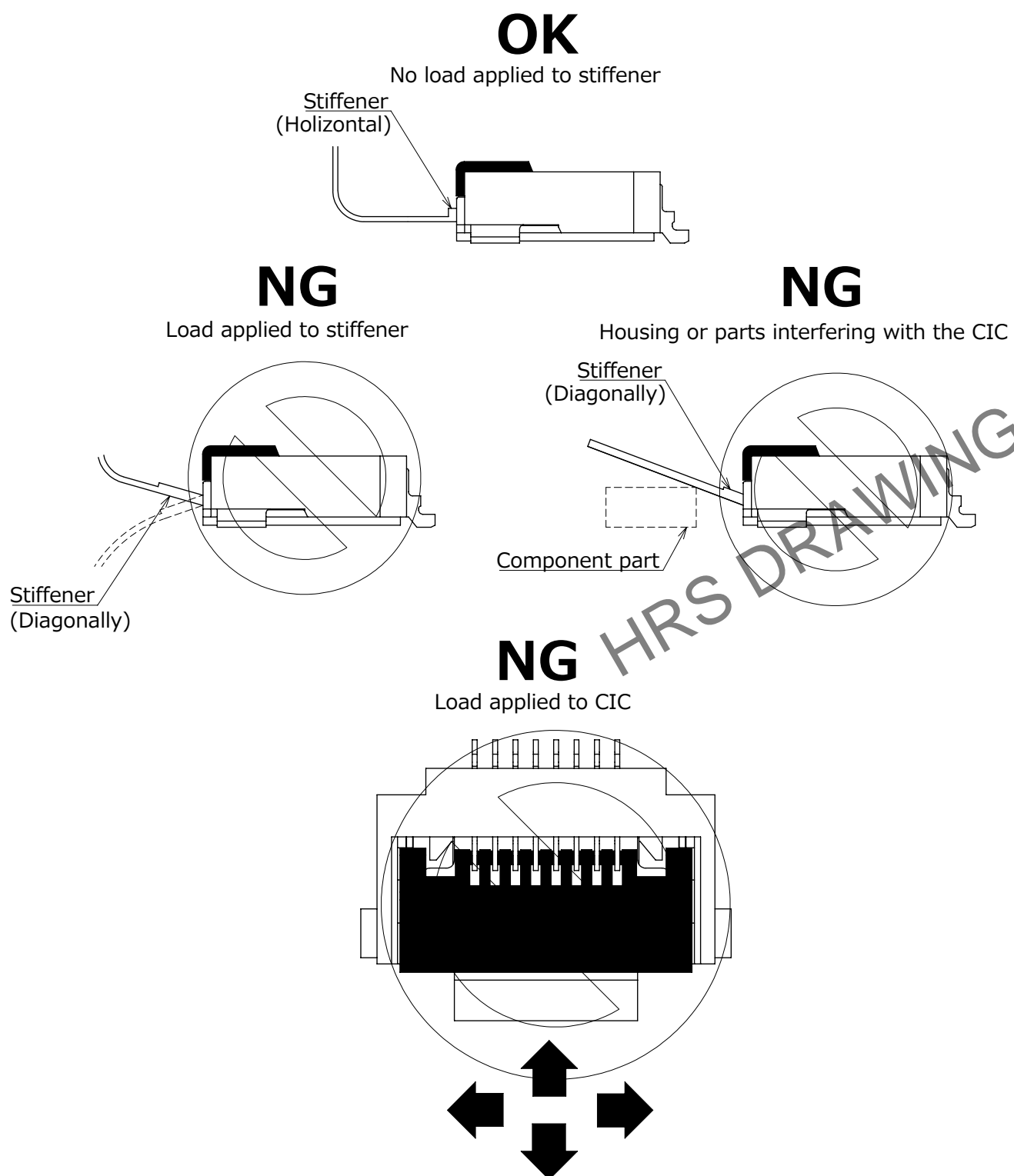

<Instruction manual(3)>

HRS	DRAWING NO.	EDC-402412-00-00	1/6/7
	PART NO.	FH52C-12S-1SH	
	CODE NO.	CL0580-4661-0-00	

May.1.2024 Copyright 2024 HIROSE ELECTRIC CO., LTD. All Rights Reserved.
In case of consideration for using Automotive equipment / device which demand high reliability, kindly contact our sales window correspondents.

[Recommended reflow temperature profile]

The temperatures mentioned above refer to the PCB surface temperature near the connector leads.
For specific applications, the recommended temperature may vary depending on type/volume/thickness of solder paste and size/thickness of PCB.
Please consult with your solder paste and equipment manufacturer for specific recommendations.

- Reflow method:IR reflow
- Number of reflow cycles:2 cycles MAX.

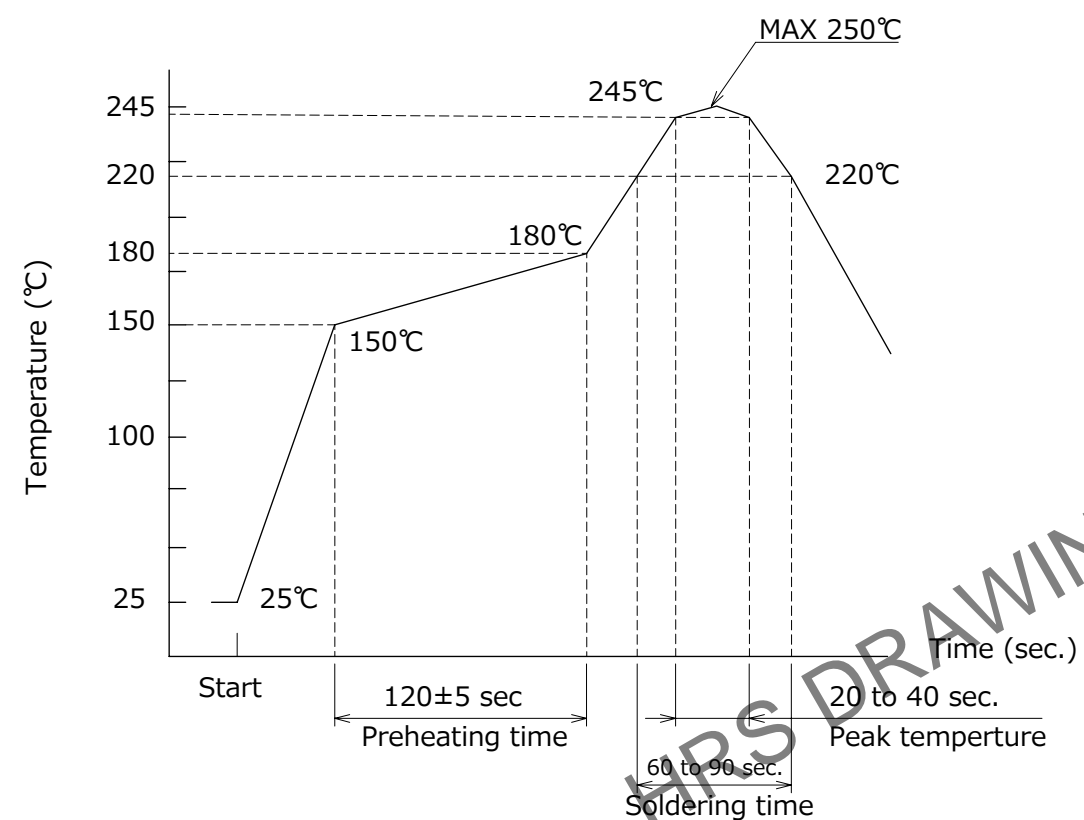

[Others]

- Attachment of foreign particles with the connector contact may lead to conduction failure.
In this particular case, the conduction failure may be fixed by re-inserting the CIC.

<Recommended reflow temperature profile>

HRS

DRAWING NO.	EDC-402412-00-00
PART NO.	FH52C-12S-1SH
CODE NO.	CL0580-4661-0-00

1/7