

Feb.1.2025 Copyright 2025 HIROSE ELECTRIC CO., LTD. All Rights Reserved.
In case of consideration for using Automotive equipment / device which demand high reliability, kindly contact our sales window correspondents.

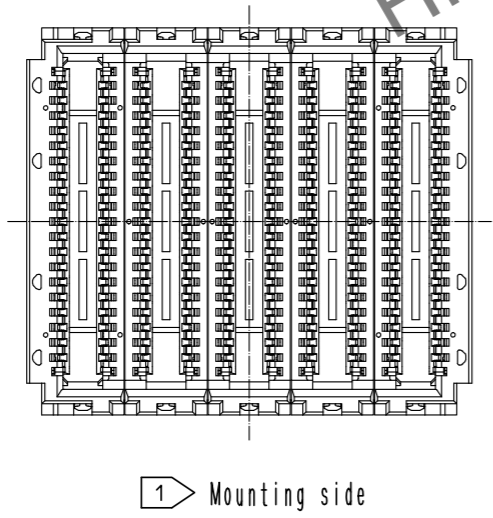
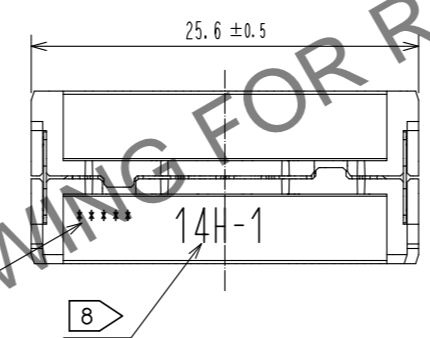
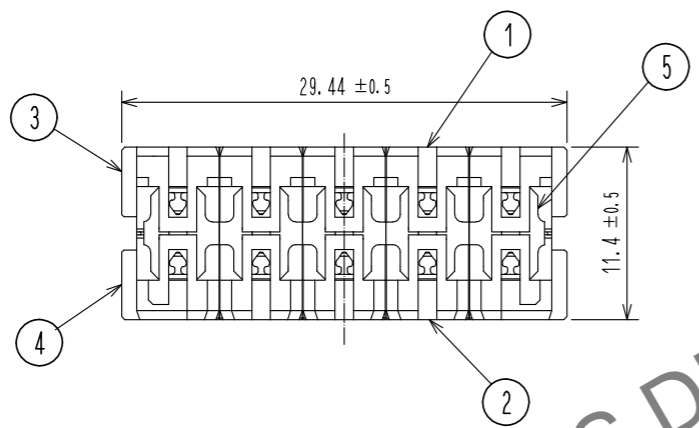
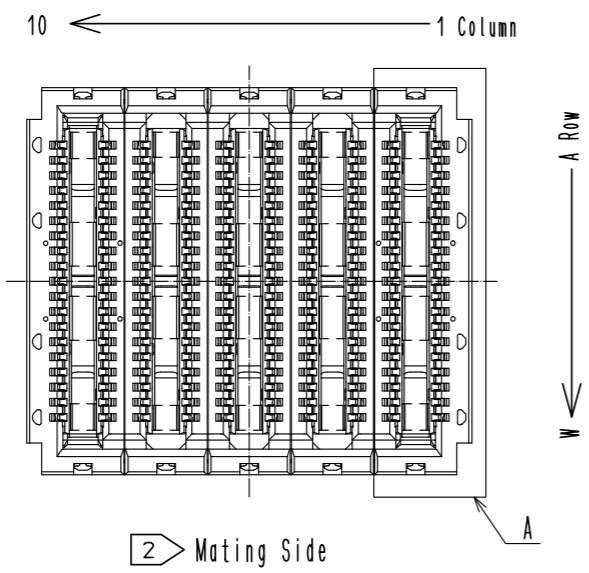

- Note.
- 1 Mounting side is mated with Plug-M:IT8M*-120P-BGA-1H(**) and fixed with the latch. IT8M*-120P-BGA-0H(**) cannot be mated.
 - 2 Mating side is mated with Plug-D:IT8D*-120P-BGA-+H(**).
 - 3 Lot No. shall be marked at the indicated position.
 - 4 IT8 Series apply GSSG.. pin assign as shown. Twisted pairs are indicated by the hatch marks. Twisted pairs are twisted in the center to reduce FEXT.
 - 5 The indicated mother board and daughter card shall be fastened to the additional reinforcements to prevent the stress on IT8*-120P-BGA-+H(**) solder joints.
 - 6 This product consists of 120 signal contacts and 70 ground contacts.
 - 7 The spacer height of this product assembled with mounted IT8M*-120P-BGA-1H(**) and IT8D*-120P-BGA-+H(**) shall be indicated in Table 1.
 - 8 '14H-1' shall be marked at the indicated position.

7 Table 1 Spacer height

Spacer height (X)	15	16
Plug-D (Detachable Side)	IT8D*-***P-BGA-0H(**)	IT8D*-***P-BGA-1H(**)
Interposer	IT8*-***S-14H-1(**)	
Plug-M (Mounting Side)	IT8M*-***P-BGA-1H(**)	IT8M*-***P-BGA-1H(**)

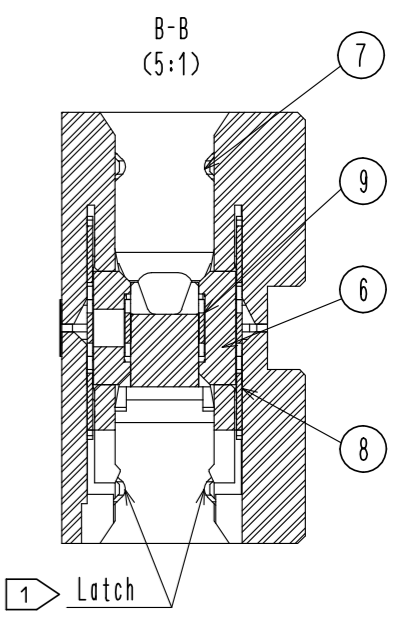
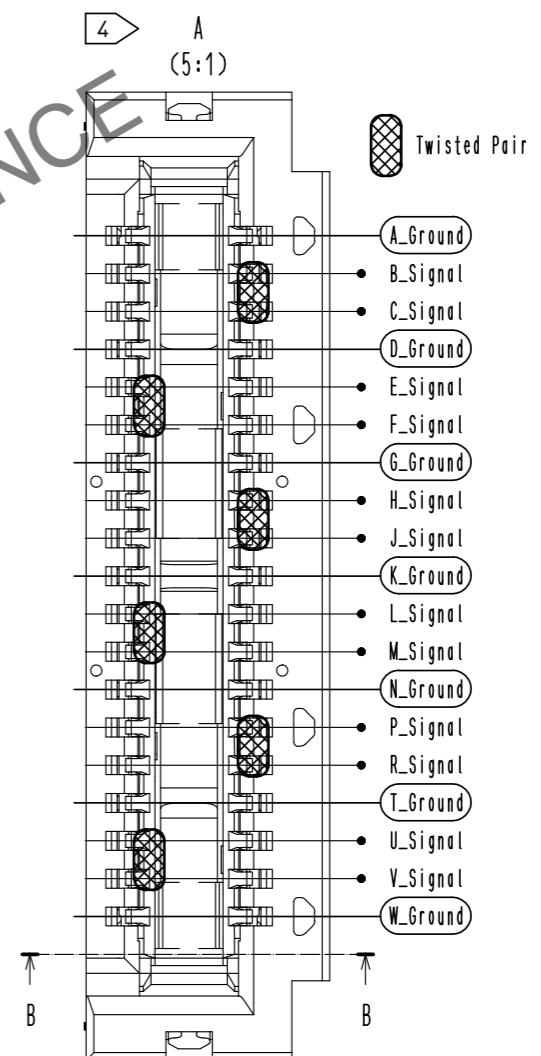

5	SUS		9	SUS	
4	PPS	BLACK, UL94V-0	8	SUS	
3	PPS	GRAY, UL94V-0	7	Copper Alloy	Contact area: Nickel 1.27 μm min. +Gold 0.76 μm min.
2	PPS	BLACK, UL94V-0			Other area: Nickel 1.27 μm min.
1	PPS	GRAY, UL94V-0	6	LCP	BLACK, UL94V-0
NO.	MATERIAL	FINISH . REMARKS	NO.	MATERIAL	FINISH . REMARKS
UNITS	mm	SCALE 2 : 1	COUNT 0	DESCRIPTION OF REVISIONS DIS-F-00009683	DESIGNED CHUNKAI YANG
		APPROVED : TM. MATSUO 20210603	DESIGNED	CHUNKAI YANG	CHECKED AS. MATSUZAWA
HIROSE ELECTRIC CO., LTD.		CHECKED : AS. MATSUZAWA 20210603	DATE	20210604	
		DESIGNED : CHUNKAI YANG 20210603	DRAWING NO.	EDC-393354-00-00	
		DRAWN : CHUNKAI YANG 20210603	PART NO.	IT8LN-120S-14H-1	
			CODE NO.	CL0636-3713-0-00	
				1/2	

Feb.1.2025 Copyright 2025 HIROSE ELECTRIC CO., LTD. All Rights Reserved.
 In case of consideration for using Automotive equipment / device which demand high reliability, kindly contact our sales window correspondents.

IT8 Assembly Process

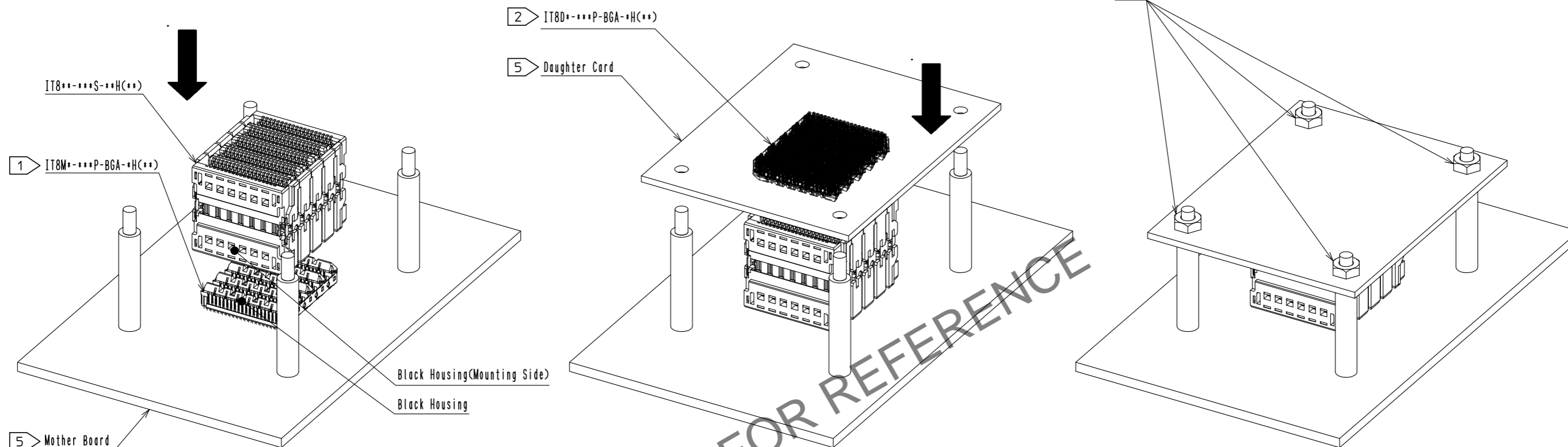

1) Insert mounting side of Interposer(IT8***S**H(**)) by pressing on top of Interposer into reflowed Mounting Plug(IT8M***P-BGA-H(**)) having black housings.

2) Insert Detachable Plug(IT8D***P-BGA-H(**)) having gray housings into mating side of Interposer(IT8***S**H(**)).

3) Install and tighten nuts to fix mated Detachable Plug after completion of mating.

IT8 Mated Condition

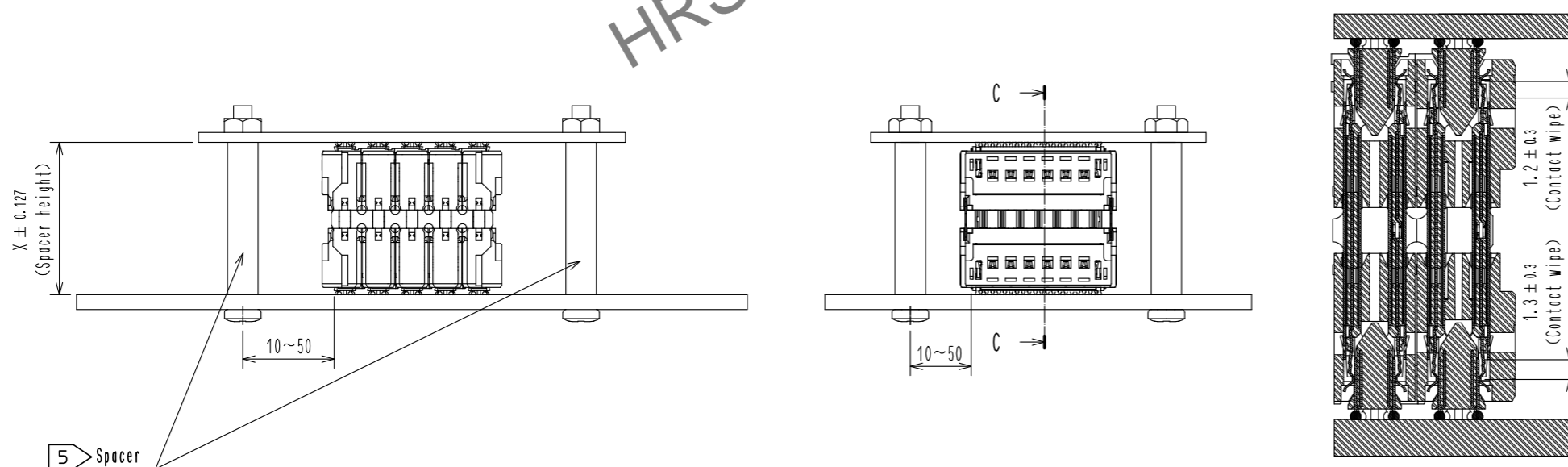

HRS	DRAWING NO.	EDC-393354-00-00
	PART NO.	IT8LN-120S-14H-1
	CODE NO.	CL0636-3713-0-00
		$\frac{2}{2}$