

Sep.1.2024 Copyright 2024 HIROSE ELECTRIC CO., LTD. All Rights Reserved.
 In case of consideration for using Automotive equipment / device which demand high reliability, kindly contact our sales window correspondents.

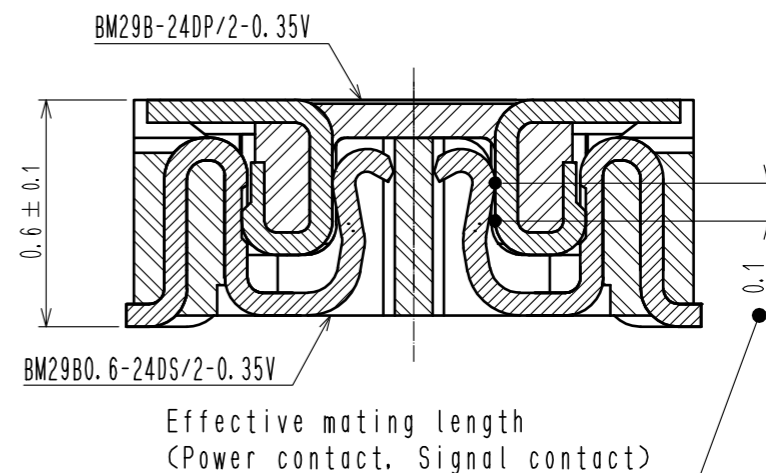
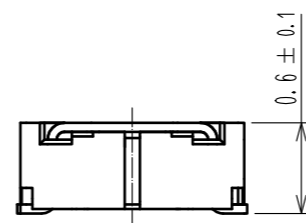
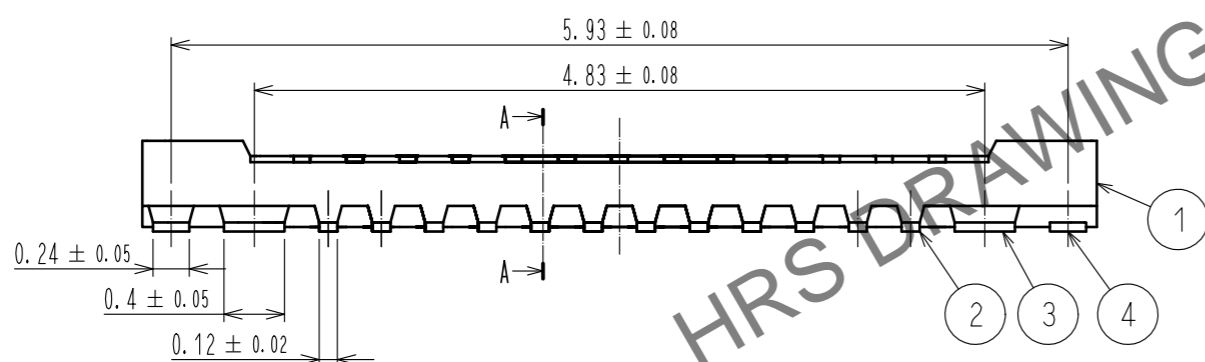
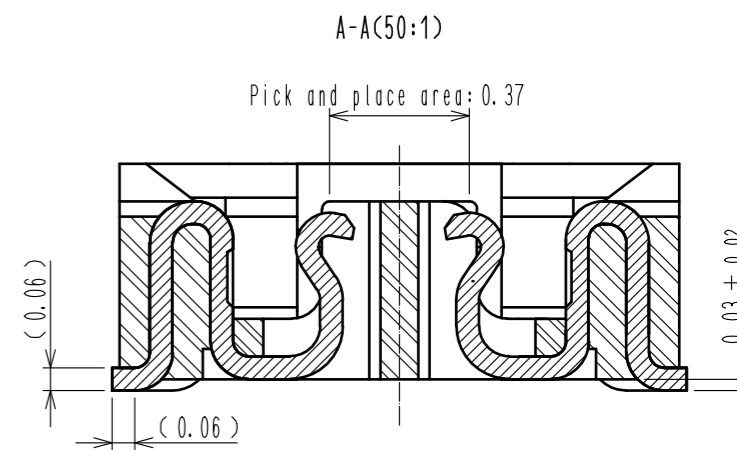
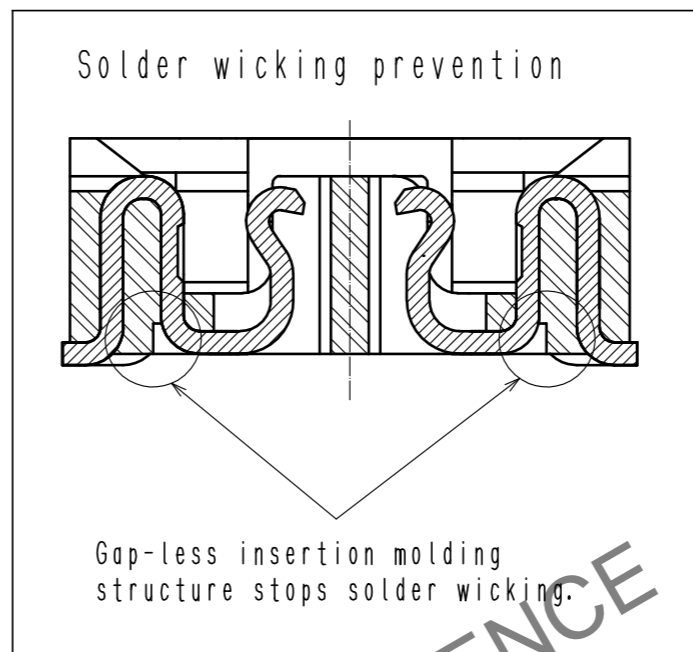
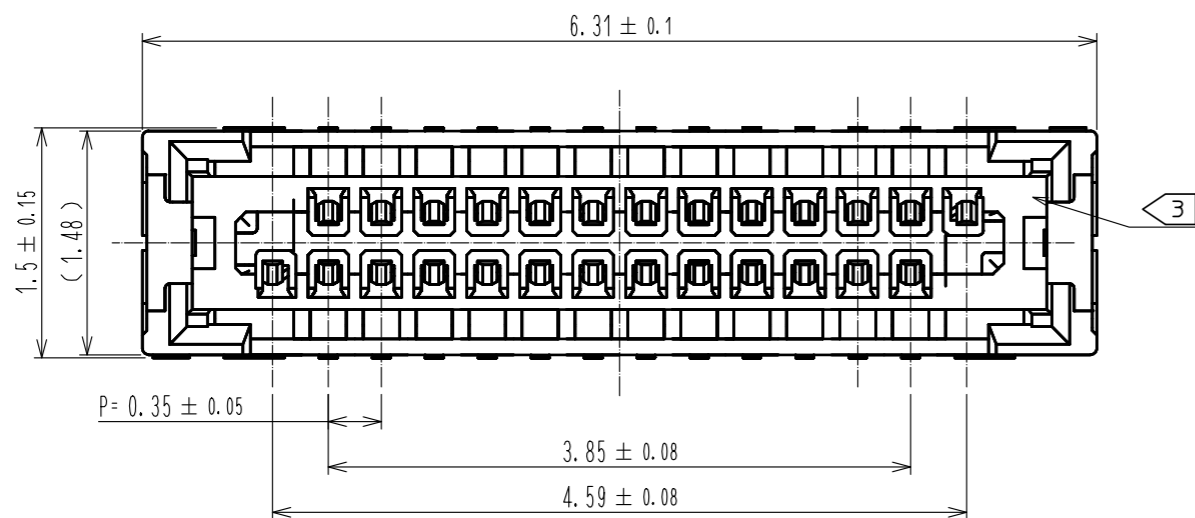

- △ NOTE 1 . All lead co-planarity will be 0.08mm MAX.
 ② . Contact plating specifications
 Contact area : Gold 0.05 μm MIN
 SMT lead : Gold 0.05 μm MIN
 Under plating : Nickel 1 μm MIN
 (Surface : Sealing)
 ③ . Cavity number is indicated at approximate location.

NO.	MATERIAL	FINISH . REMARKS	NO.	MATERIAL	FINISH . REMARKS
4	PHOSPHOR BRONZE	②	8	PS	CLEAR. REINFORCEMENT COLLAR
3	PHOSPHOR BRONZE	②	7	PS	BLACK. PLASTIC REEL
2	PHOSPHOR BRONZE	②	6	POLYESTER	CLEAR. COVER TAPE
1	LCP	UL94 V-0. BLACK	5	PS	SMOKE GRAY. EMBOSSED CARRIER TAPE

UNITS	SCALE	COUNT	DESCRIPTION OF REVISIONS	DESIGNED	CHECKED	DATE
mm	20:1	1	DIS-H-00019141	RT. OSAKI	RT. SHIMIZU	20230915

APPROVED	CHECKED	DESIGNED	DRAWN	DRAWING NO.	PART NO.	CODE NO.
MO. ISHIDA	TS. MIYAZAKI	YT. TAKAGI	YT. TAKAGI	EDC-378714-51-00	BM29B0.6-24DS/2-0.35V(51)	CL0673-7053-0-51

Sep.1.2024 Copyright 2024 HIROSE ELECTRIC CO., LTD. All Rights Reserved.
In case of consideration for using Automotive equipment / device which demand high reliability, kindly contact our sales window correspondents.

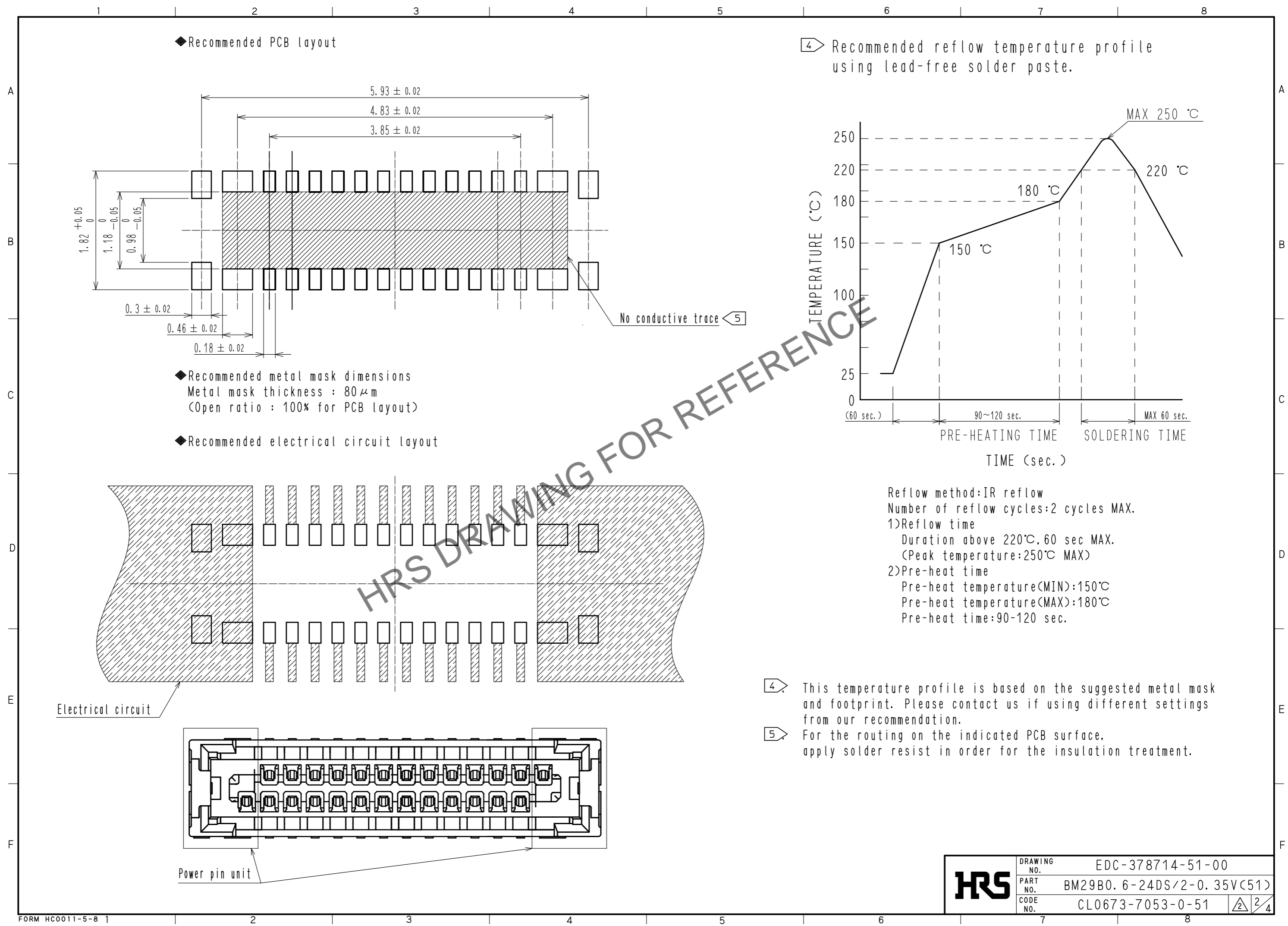

HRS	DRAWING NO.	EDC-378714-51-00	
	PART NO.	BM29B0. 6-24DS/2-0. 35V(51)	
	CODE NO.	CL0673-7053-0-51	2/4

Sep.1.2024 Copyright 2024 HIROSE ELECTRIC CO., LTD. All Rights Reserved.
 In case of consideration for using Automotive equipment / device which demand high reliability, kindly contact our sales window correspondents.

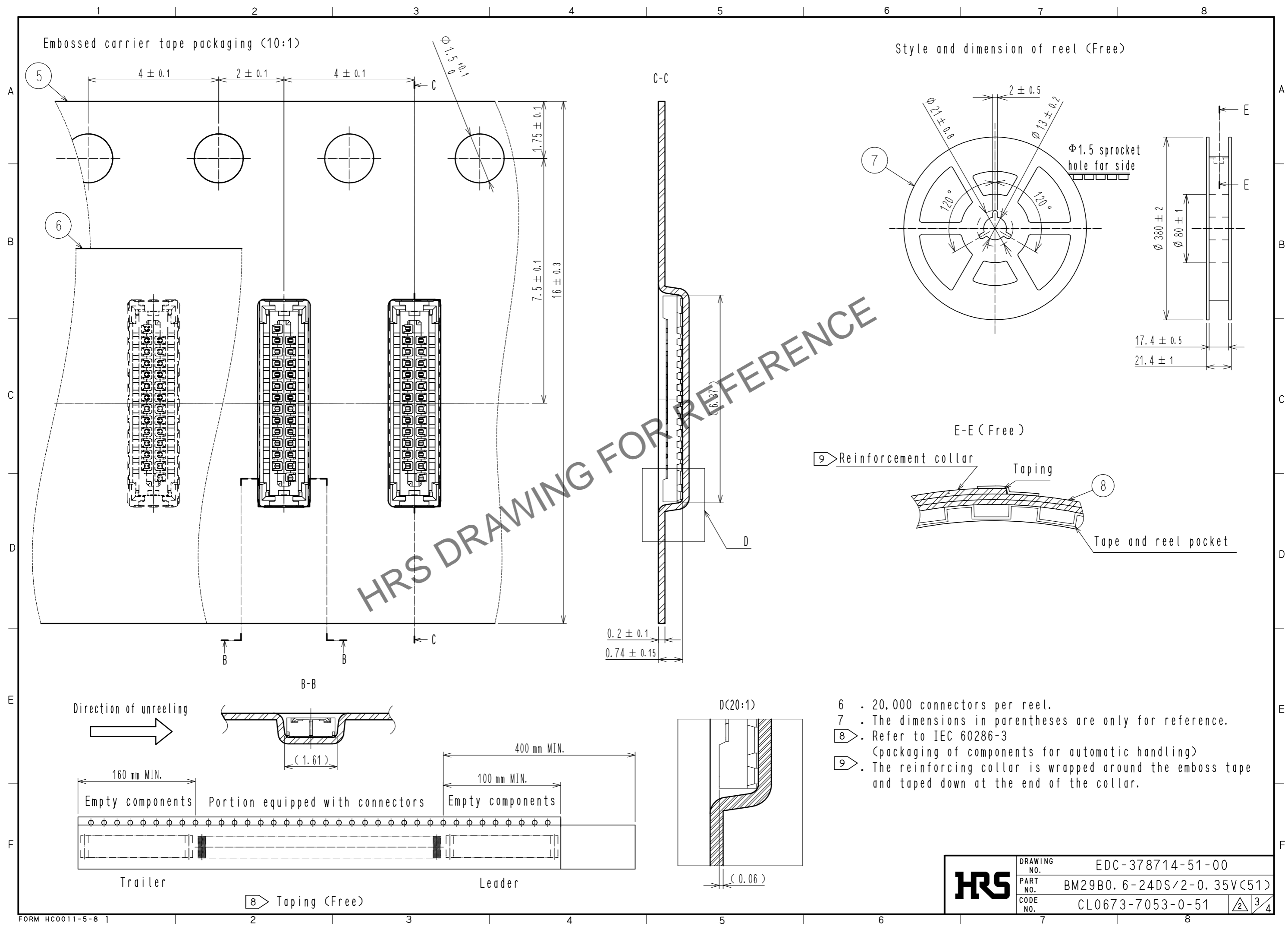

HRS	DRAWING NO.	EDC-378714-51-00	
	PART NO.	BM29B0. 6-24DS/2-0. 35V(51)	
	CODE NO.	CL0673-7053-0-51	$\frac{3}{4}$

In case of consideration for using Automotive equipment / device which demand high reliability, kindly contact our sales window correspondents.

10. Please refer to the product guideline ETAD-H1016 for detail of connector handling.

The position between the connector and PAD

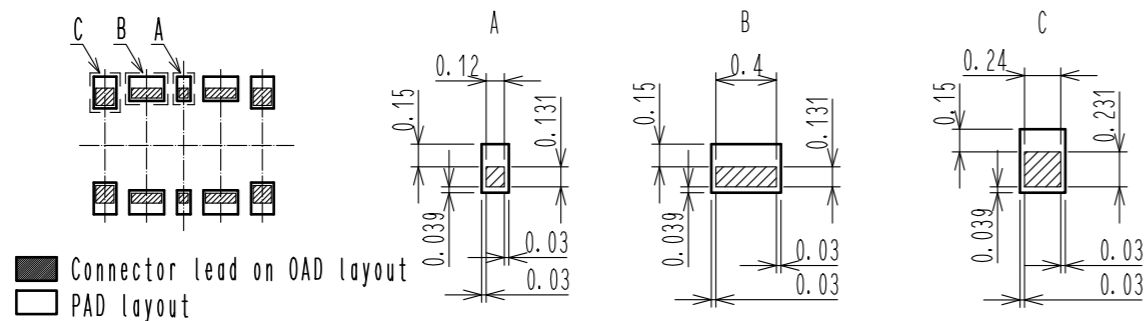

Caution for soldering

There is metal exposure area bottom of the connector.
 To avoid solder wicking from the bottom side, please design PCB PAD and stencil with recommended dimensions.

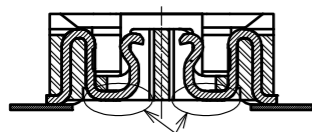

Mating method

Please mate the connector by hand.

Mating procedure

- Find the alignment area to the connector in the appropriate mating position.
 This connector has an alignment chamber (guidance ribs) on receptacle side and "r" on plug side, so that the connector will be self-aligned.
 When the connector comes to the appropriate position, the connector goes into the aligned position.
 When aligned, it can be felt by hand.

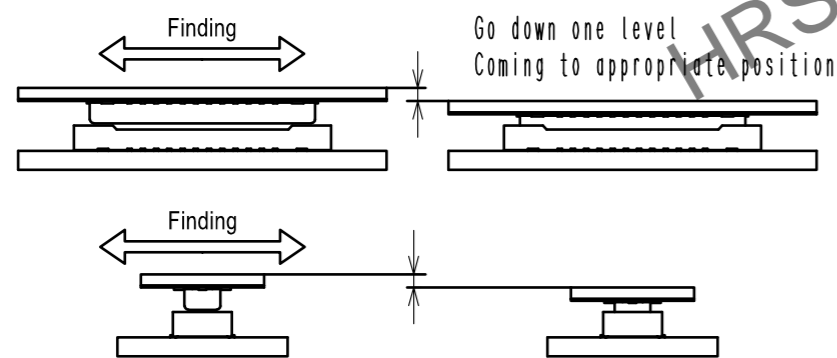

- When guiding, the connectors are aligned parallel to each other, with longitudinal and lateral movements restricted. Mate them properly by applying force in this condition.

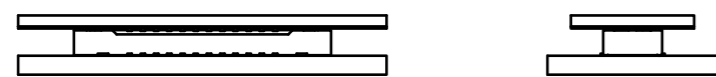

- Make sure the connectors are mated correctly. If one side is floating or the connectors are mated in one direction, un-mate them once, and then mate them again, following the procedures above from the beginning.

Un-mating method

Please un-mate the connector by hand

- Un-mate the connectors parallel to each other. However, if the connectors have high pin counts or thinner FPC and stiffener, it becomes more difficult to do so.

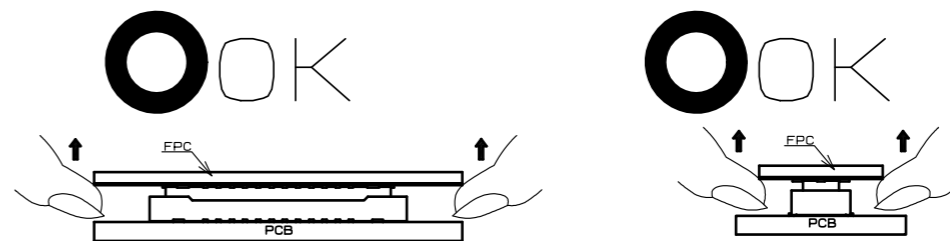

- If the connector cannot be un-mated parallel it can be removed diagonally from the pitch direction. Be careful to do so since this action applies stress on the contact.

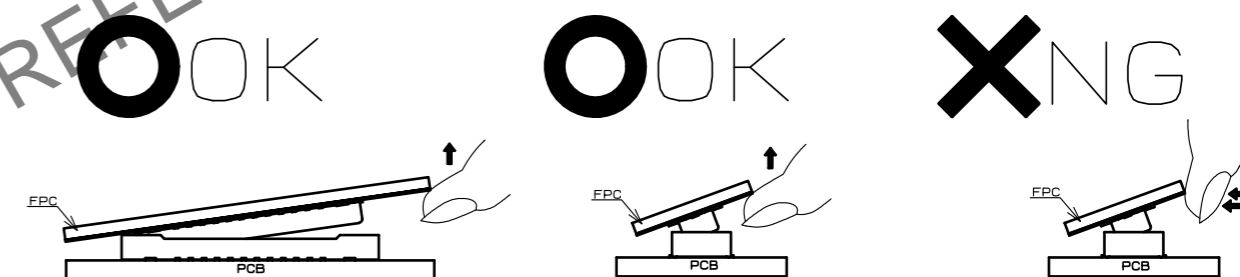

- If the FPC is not rigid, the connector can be broken. Please check the action of the FPC to be used repeatedly at the time of trial production. Be careful to un-mate them from the pitch direction, pulling it from the corner can also risk to putting stress on contacts.

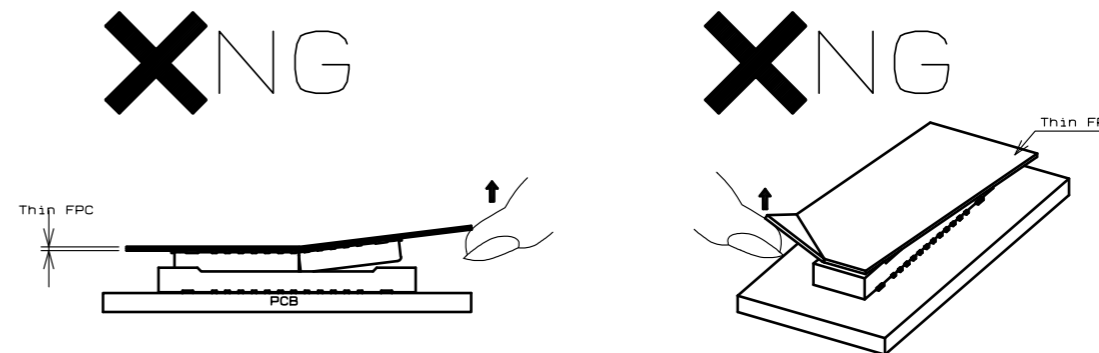

HRS	DRAWING NO.	EDC-378714-51-00	
	PART NO.	BM29B0. 6-24DS/2-0. 35V<51>	
	CODE NO.	CL0673-7053-0-51	4/4