

Oct.1.2024 Copyright 2024 HIROSE ELECTRIC CO., LTD. All Rights Reserved.
 In case of consideration for using Automotive equipment / device which demand high reliability, kindly contact our sales window correspondents.

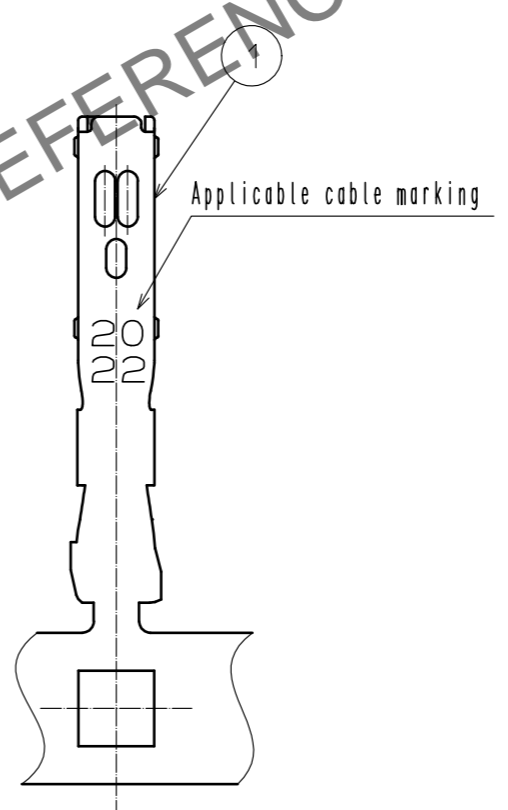

2 Reel style and dimensions

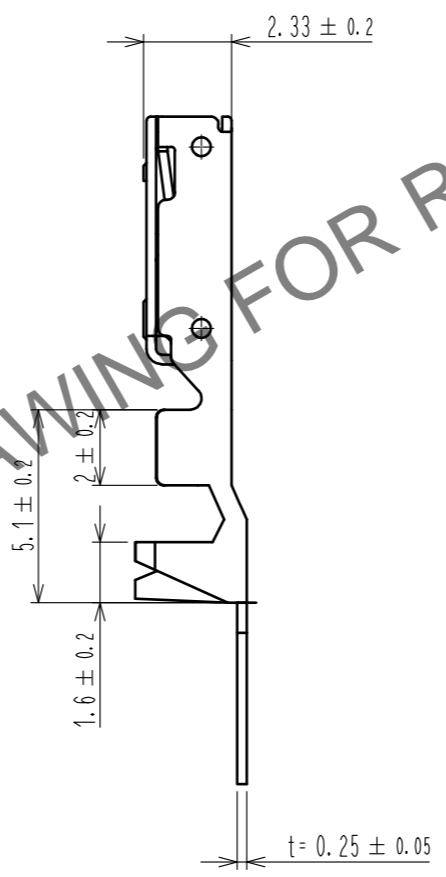
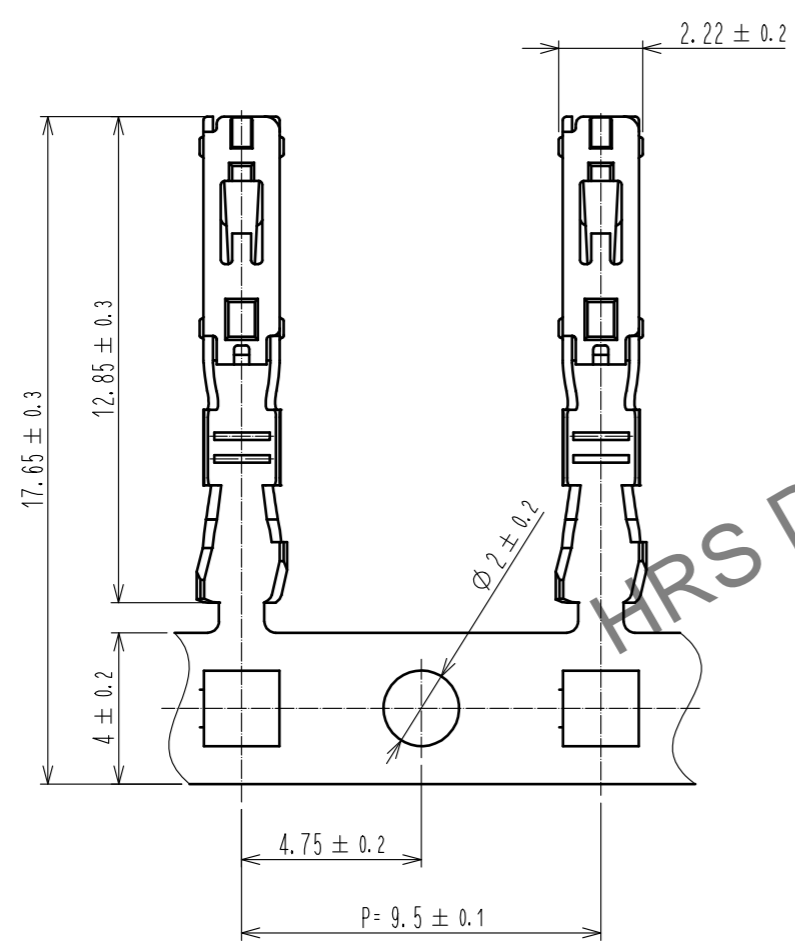
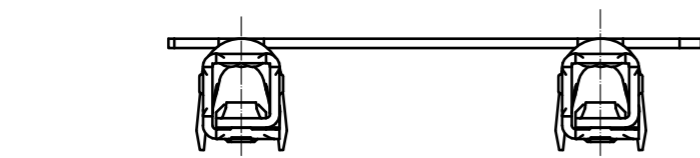
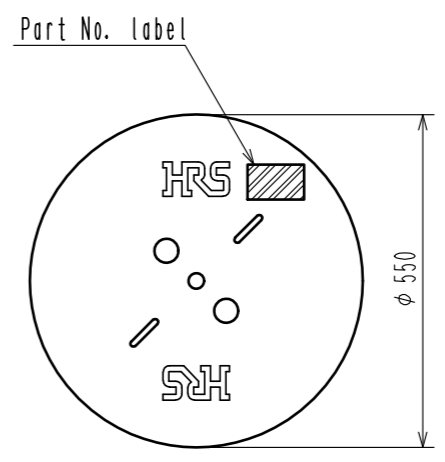

Detail of part No. label

HRS		検査
品名コード	CL680-0602-0	Inspection
品名	DF63W-2022SCF	
数量	4000	
仕様		
LOT No.		
継ぎ目		

Section
 Lot No.
 Specification
 Quantity
 Part No.
 Code No.

Notes

- 1RL : 4000 contacts.
- 2 Style of reel and box are shown in figure.
- Up to 3 reels are packed up in one box.
- Please be sure to check the form of crimping using a cable when you adjust applicator.

UNITS mm	SCALE 5 : 1	COUNT	DESCRIPTION OF REVISIONS		DESIGNED	CHECKED	DATE
			APPROVED : KI. AKIYAMA	15.12.17			
HRS HIROSE ELECTRIC CO., LTD.	CHECKED : TS. FUKUSHIMA	15.12.16	DRAWING NO.		EDC-359244-00-00		
	DESIGNED : YK. YAMAGUCHI	15.12.16	PART NO.		DF63W-2022SCF		
	DRAWN : HK. HAYASHI	15.12.16	CODE NO.		CL680-0602-0-00		
					1/1		