

Jul.1.2024 Copyright 2024 HIROSE ELECTRIC CO., LTD. All Rights Reserved.
 In case of consideration for using Automotive equipment / device which demand high reliability, kindly contact our sales window correspondents.

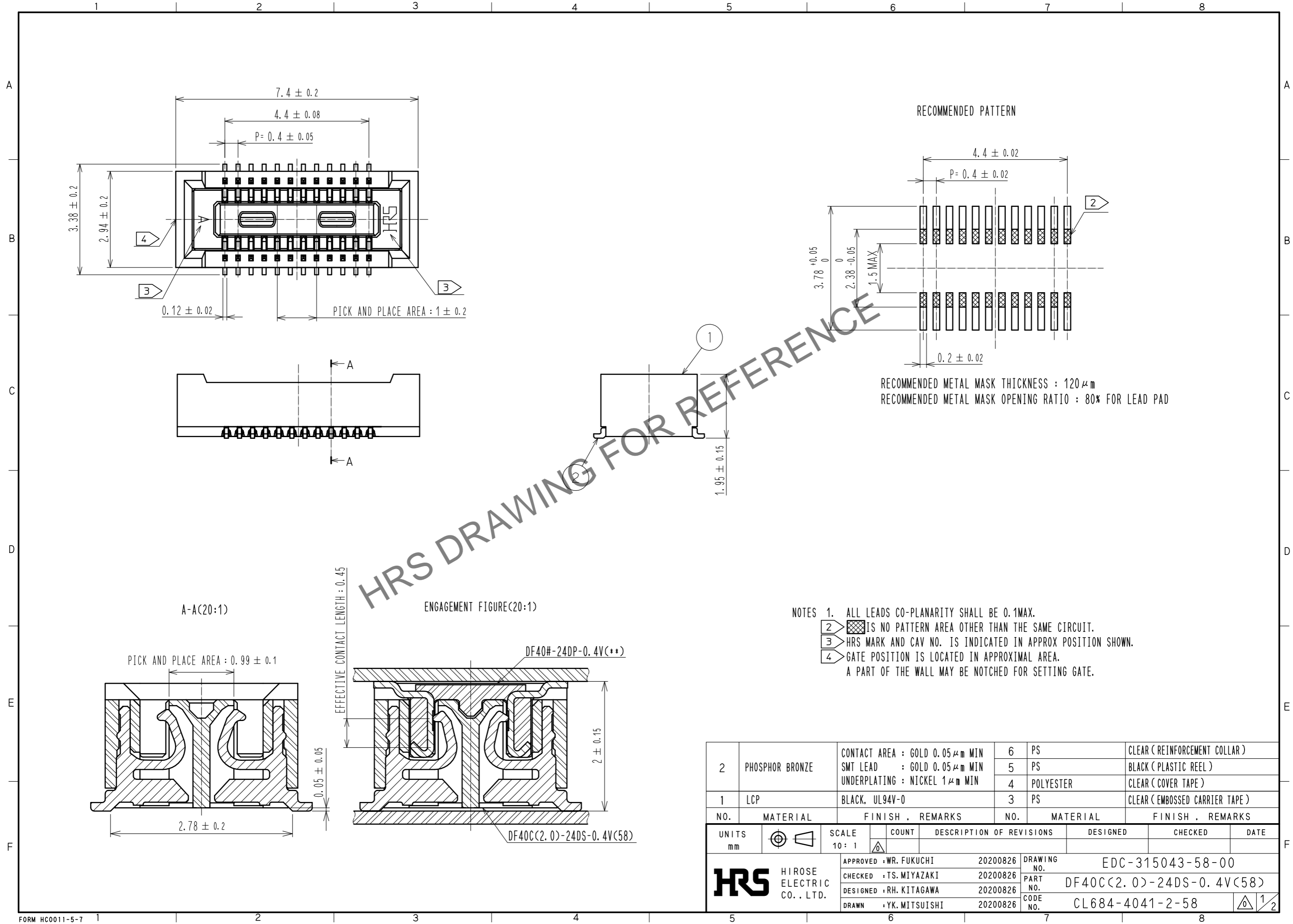

NO.	MATERIAL	FINISH . REMARKS	NO.	MATERIAL	FINISH . REMARKS
2	PHOSPHOR BRONZE	CONTACT AREA : GOLD $0.05 \mu\text{m}$ MIN SMT LEAD : GOLD $0.05 \mu\text{m}$ MIN UNDERPLATING : NICKEL $1 \mu\text{m}$ MIN	6	PS	CLEAR (REINFORCEMENT COLLAR)
			5	PS	BLACK (PLASTIC REEL)
			4	POLYESTER	CLEAR (COVER TAPE)
1	LCP	BLACK, UL94V-0	3	PS	CLEAR (EMBOSSED CARRIER TAPE)

UNITS	SCALE	COUNT	DESCRIPTION OF REVISIONS	DESIGNED	CHECKED	DATE
mm	10:1					
APPROVED : WR. FUKUCHI			20200826	DRAWING NO. EDC-315043-58-00		
CHECKED : TS. MIYAZAKI			20200826	PART NO. DF40C(2.0)-24DS-0.4V(58)		
DESIGNED : RH. KITAGAWA			20200826	CODE NO. CL684-4041-2-58		
DRAWN : YK. MITSUISHI			20200826	1/2		

In case of consideration for using Automotive equipment / device which demand high reliability, kindly contact our sales window correspondents.

EMBOSSED CARRIER TAPE DIMENSIONS (5:1)

STYLE AND DIMENSION OF REEL (FREE SIZE)

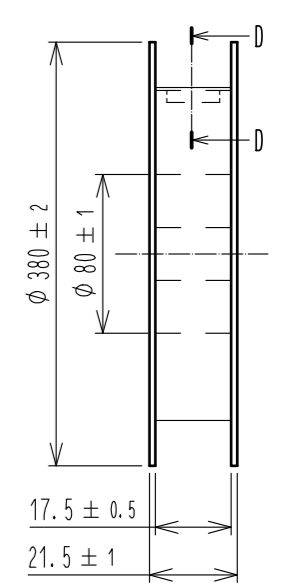
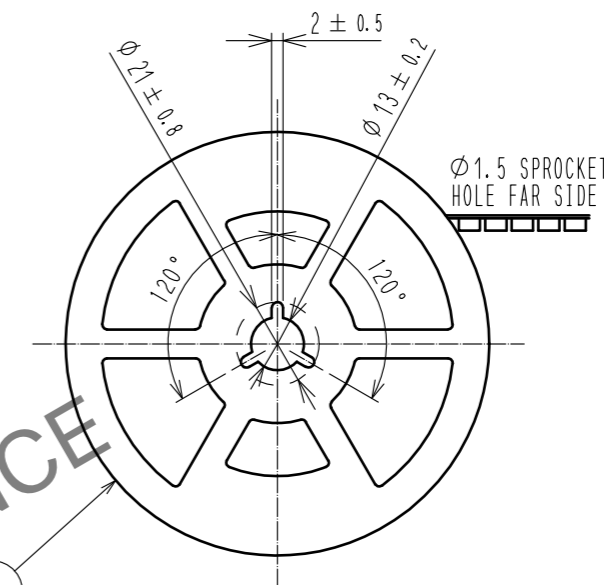
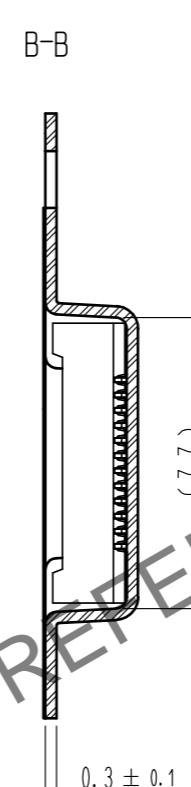
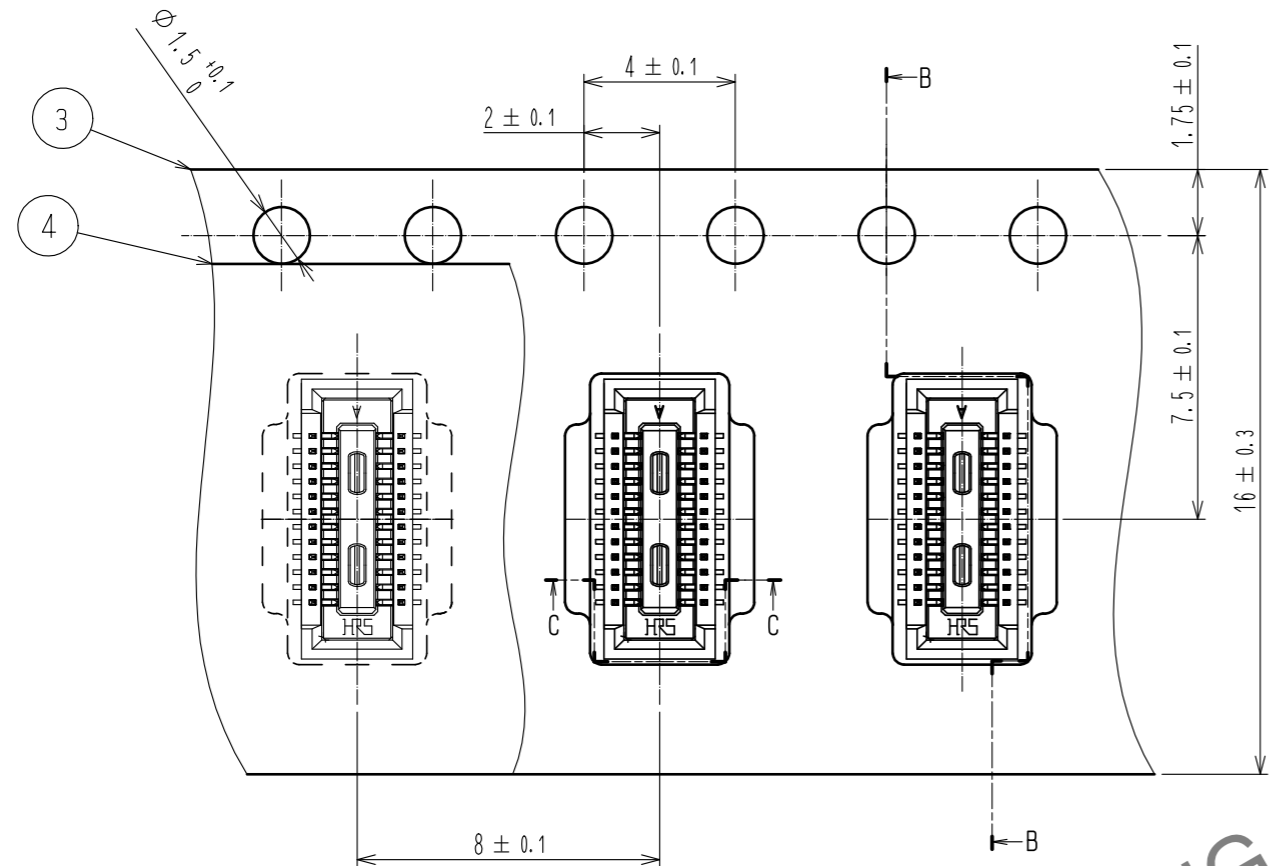

DIRECTION OF UNREELING

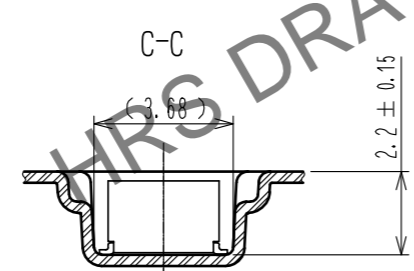

D-D (FREE)

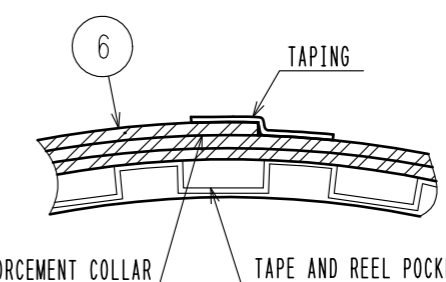

- NOTES
5. PER REEL 1000 CONNECTORS.
 6. THE DIMENSIONS IN PARENTHESES ARE FOR REFERENCE.
 7. REFER TO JIS C 0806, IEC 60286-3. (PACKAGING OF COMPONENTS FOR AUTOMATIC HANDLING)
 8. AFTER PACKAGING, ROLL 2 METERS OF THE REINFORCEMENT COLLAR TO OUTER CIRCUMFERENCE OF TAPE AND REEL POCKET. AND TAPE DOWN AT THE END OF THE COLLAR.

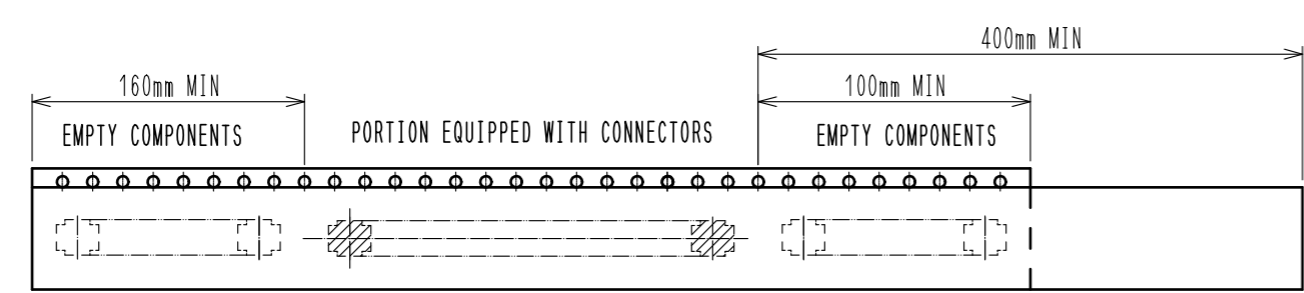

TRAILER

TAPING(FREE)

LEADER

HRS	DRAWING NO.	EDC-315043-58-00
	PART NO.	DF40C(2.0)-24DS-0.4V(58)
	CODE NO.	CL684-4041-2-58
		\triangle 2/2