

Jul.1.2021 Copyright 2021 HIROSE ELECTRIC CO., LTD. All Rights Reserved.  
 In case of consideration for using Automotive equipment / device which demand high reliability, kindly contact our sales window correspondents.

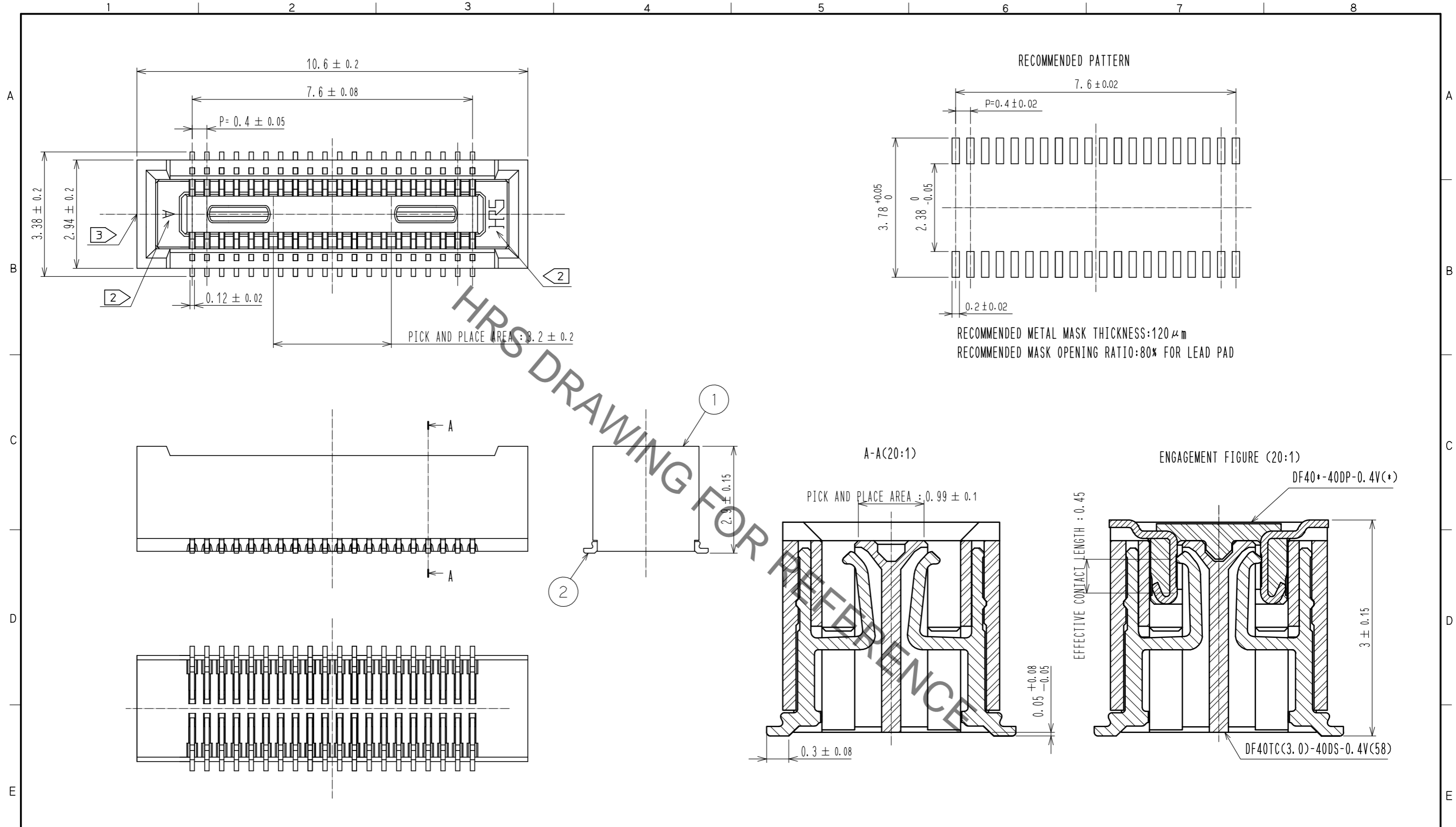

NOTES ) 1. ALL LEADS METAL FITTINGS CO-PLANARITY SHALL BE 0.1mm MAX.  
 2 HRS MARK AND CAV NO. ARE INDICATED IN APPROXIMAL POSITION SHOWN.  
 3 GATE IS COATED IN APPROXIMAL AREA.

2	COPPER ALLOY	CONTACT AREA: GOLD 0.05 μm MIN SMT LEAD: GOLD 0.05 μm MIN UNDERPLATING: NICKEL 1 μm MIN	6	PS	CLEAR, REINFORCEMENT COLLAR		
			5	PS	BLACK, PLASTIC REEL		
			4	POLYESTER	CLEAR, COVER TAPE		
1	LCP	BLACK, UL94V-0	3	PS	CLEAR, EMBOSSED CARRIER TAPE		
NO.	MATERIAL	FINISH, REMARKS	NO.	MATERIAL	FINISH, REMARKS		
UNITS mm		SCALE 10 : 1	COUNT	DESCRIPTION OF REVISIONS	DESIGNED	CHECKED	DATE
<b>HRS</b> HIROSE ELECTRIC CO., LTD.		APPROVED : WR. FUKUCHI	20210402	DRAWING NO.	EDC-388645-58-00		
		CHECED : TS. MIYAZAKI	20210402	PART NO.	DF40TC(3.0)-40DS-0.4V(58)		
		DESIGNED : YK. SATAKE	20210402	CODE NO.	CL0684-4276-0-58		
		DRAWN : YK. SATAKE	20210402				

Jul.1.2021 Copyright 2021 HIROSE ELECTRIC CO., LTD. All Rights Reserved.  
 In case of consideration for using Automotive equipment / device which demand high reliability, kindly contact our sales window correspondents.

EMBOSSED CARRIER TAPE PACKAGING (5:1)

STYLE AND DIMENSION OF REEL(FREE)

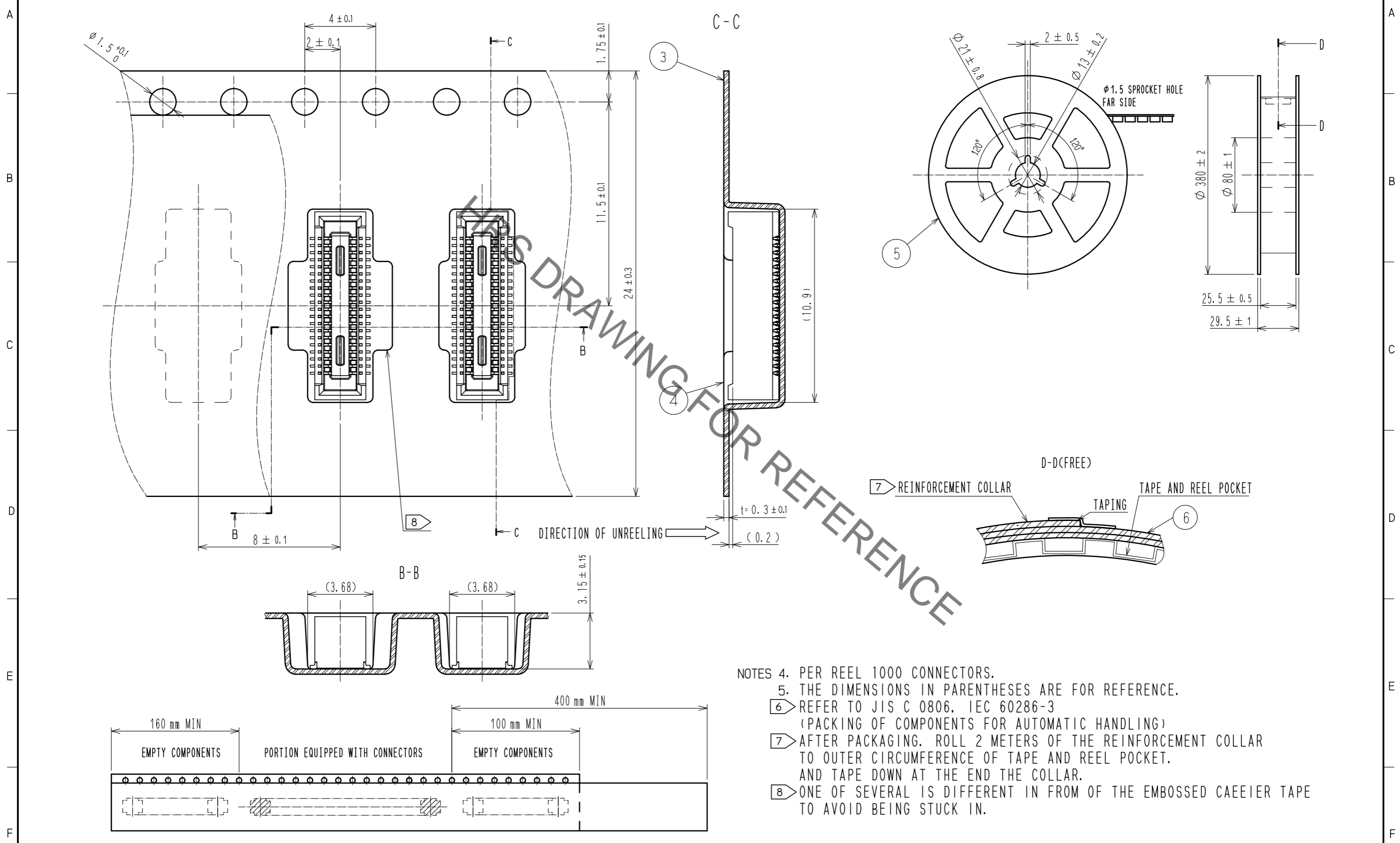

THIS DRAWING FOR REFERENCE

- NOTES
4. PER REEL 1000 CONNECTORS.
  5. THE DIMENSIONS IN PARENTHESES ARE FOR REFERENCE.
  6. REFER TO JIS C 0806, IEC 60286-3 (PACKING OF COMPONENTS FOR AUTOMATIC HANDLING)
  7. AFTER PACKAGING, ROLL 2 METERS OF THE REINFORCEMENT COLLAR TO OUTER CIRCUMFERENCE OF TAPE AND REEL POCKET. AND TAPE DOWN AT THE END THE COLLAR.
  8. ONE OF SEVERAL IS DIFFERENT IN FROM OF THE EMBOSSED CARRIER TAPE TO AVOID BEING STUCK IN.

<b>HRS</b>	DRAWING NO.	EDC-388645-58-00	
	PART NO.	DF40TC(3.0)-40DS-0.4V(58)	
	CODE NO.	CL0684-4276-0-58	2/2