

Jul.1.2021 Copyright 2021 HIROSE ELECTRIC CO., LTD. All Rights Reserved.
 In case of consideration for using Automotive equipment / device which demand high reliability, kindly contact our sales window correspondents.

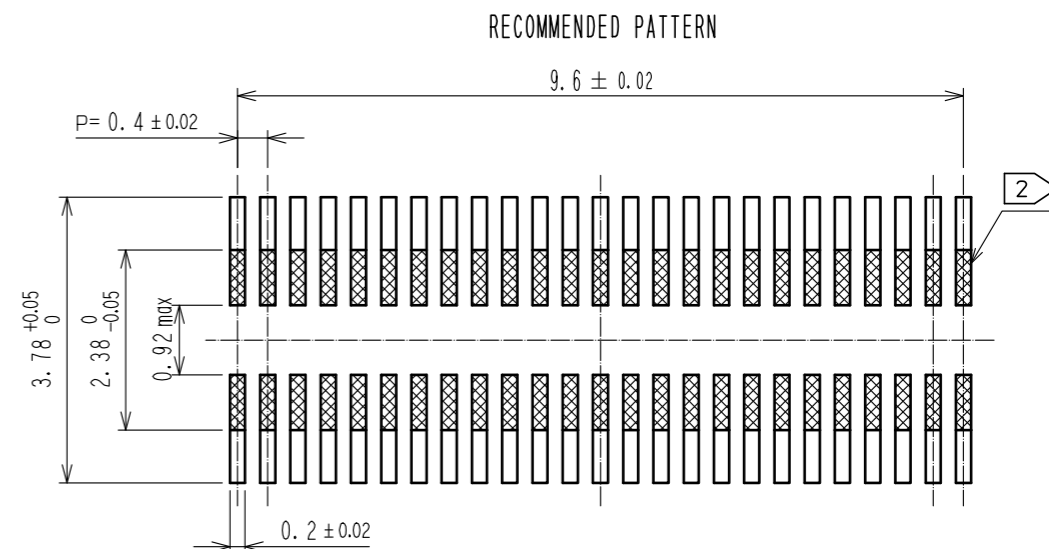

RECOMMENDED METAL MASK THICKNESS : 120 μm
 RECOMMENDED METAL MASK OPENING RATIO : 80% FOR LEAD PAD

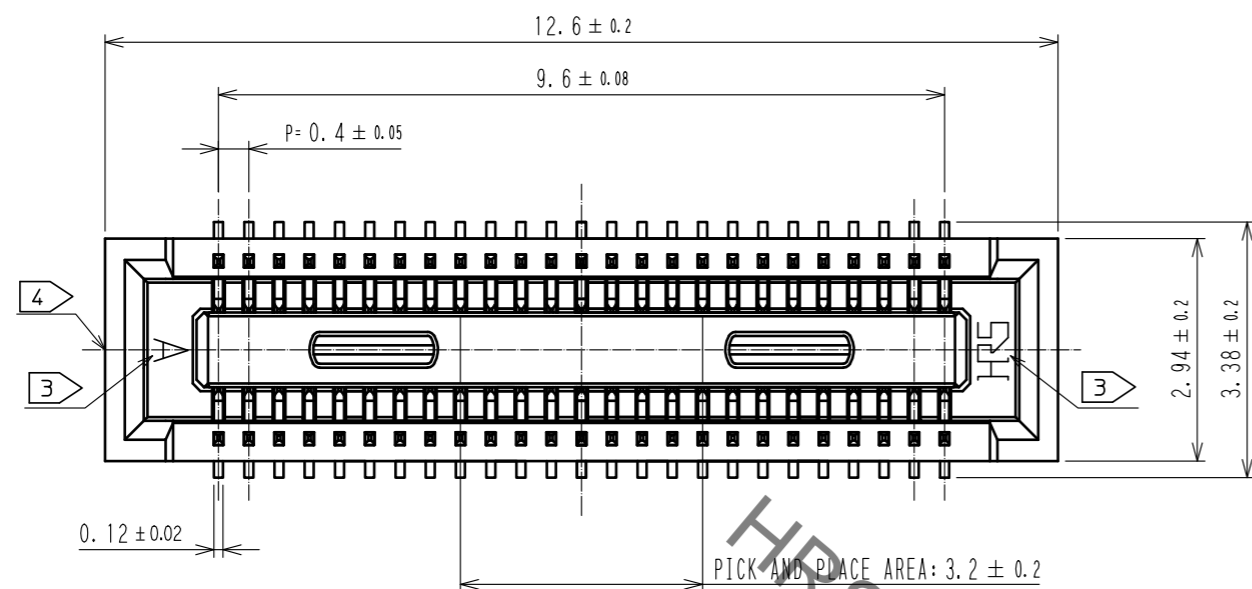
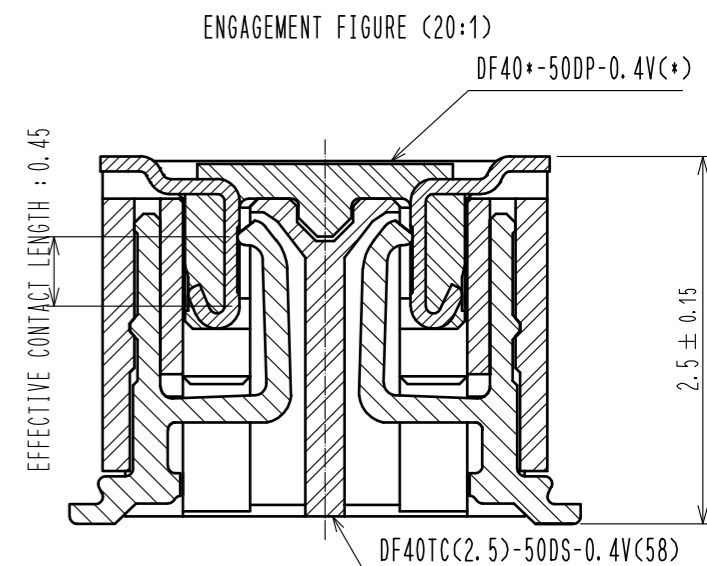
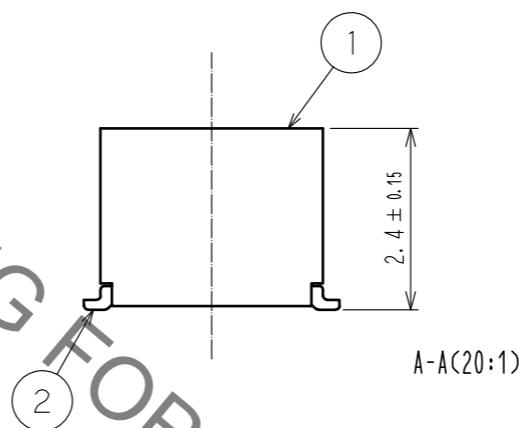
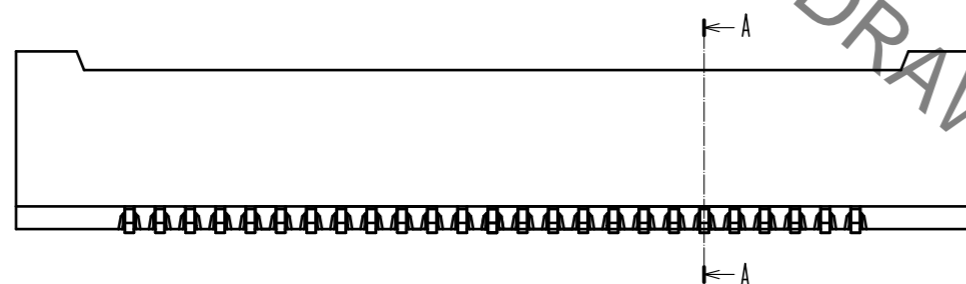

NOTE 1. ALL LEADS CO-PLANARITY SHALL BE 0.1 MAX.
 2 IS NO PATTERN AREA OTHER THAN THE SAME CIRCUIT.
 3 HRS MARK AND CAV NO. IS INDICATED IN APPROXI POSITION SHOWN.
 4 GATE POSITION IS POSITIONED IN APPROXIMAL AREA SHOWN.

2	COPPER ALLOY	CONTACT AREA: GOLD 0.05 μm MIN	5	PS	BLACK			
		SMT LEAD: GOLD 0.05 μm MIN						
		UNDERPLATING: NICKEL 1 μm MIN						
1	LCP	BLACK, UL94V-0	3	PS	CLEAR, EMBOSSED CARRIER TAPE			
NO.	MATERIAL	FINISH . REMARKS	NO.	MATERIAL	FINISH . REMARKS			
UNITS	mm	SCALE	10 : 1	COUNT	DESCRIPTION OF REVISIONS	DESIGNED	CHECKED	DATE
HIROSE ELECTRIC CO., LTD.		APPROVED : WR. FUKUCHI	20210402	DRAWING NO. EDC-389547-58-00				
		CHECKED : TS. MIYAZAKI	20210402	PART NO. DF40TC(2.5)-50DS-0.4V(58)				
		DESIGNED : YK. SATAKE	20210402	CODE NO. CL0684-4279-0-58				
		DRAWN : YK. SATAKE	20210402					

Jul.1.2021 Copyright 2021 HIROSE ELECTRIC CO., LTD. All Rights Reserved.
 In case of consideration for using Automotive equipment / device which demand high reliability, kindly contact our sales window correspondents.

EMBOSSED CARRIER TAPE PAACKAGING (5:1)

STYLE AND DIMENSION OF REEL (FREE)

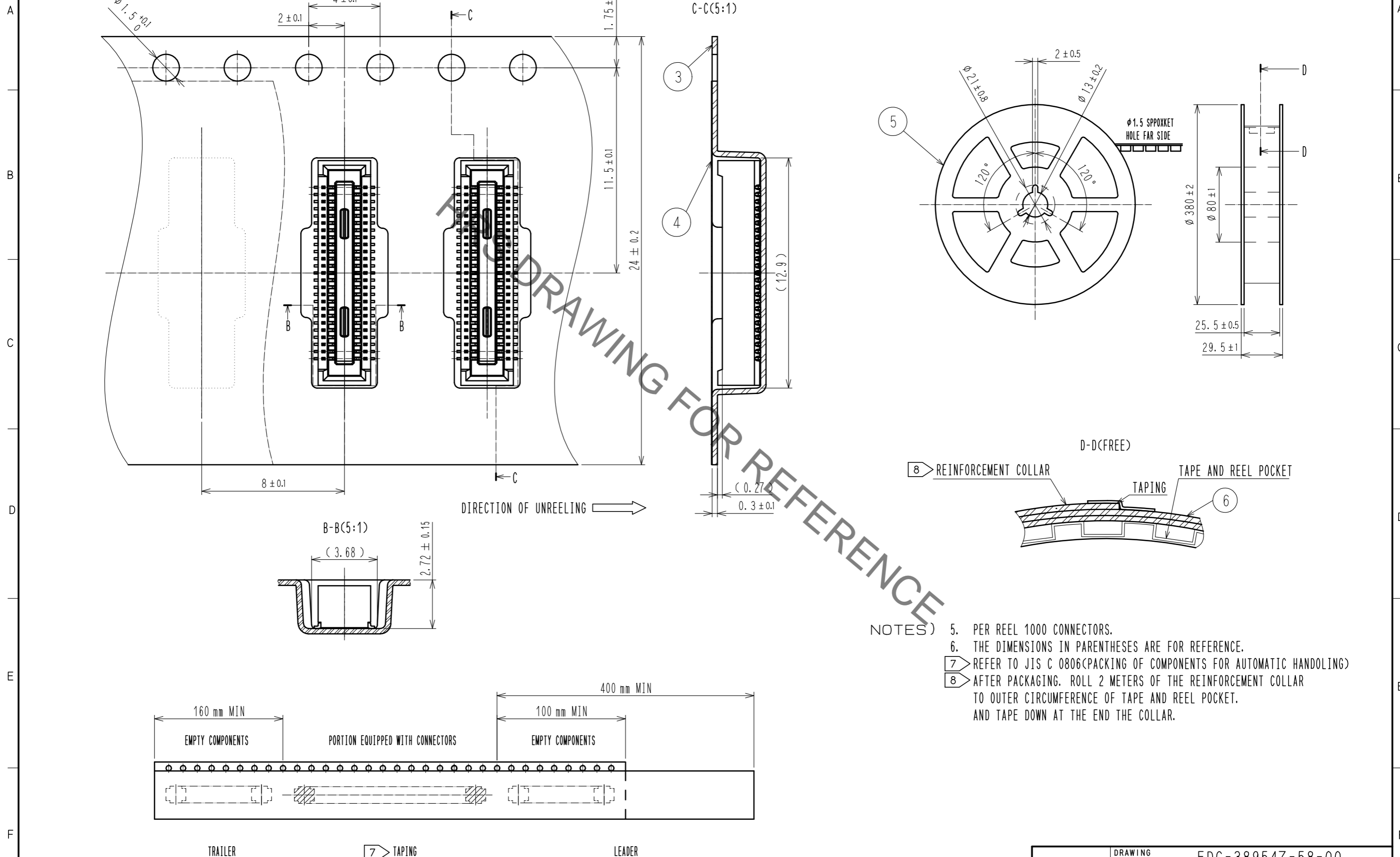

- NOTES)
5. PER REEL 1000 CONNECTORS.
 6. THE DIMENSIONS IN PARENTHESES ARE FOR REFERENCE.
 7. REFER TO JIS C 0806(PACKING OF COMPONENTS FOR AUTOMATIC HANDLING)
 8. AFTER PACKAGING. ROLL 2 METERS OF THE REINFORCEMENT COLLAR TO OUTER CIRCUMFERENCE OF TAPE AND REEL POCKET, AND TAPE DOWN AT THE END THE COLLAR.

HRS	DRAWING NO.	EDC-389547-58-00	
	PART NO.	DF40TC(2.5)-50DS-0.4V(58)	
	CODE NO.	CL0684-4279-0-58	2/2