

ELV. ROHS COMPLANT

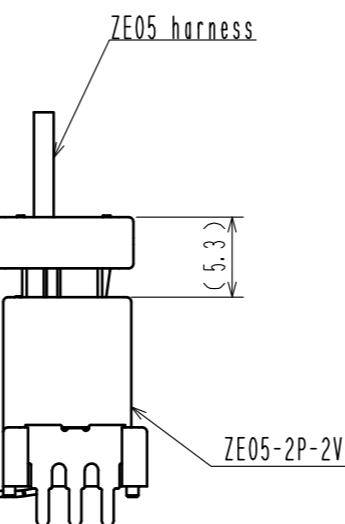

RECOMMENDED PCB PATTERN

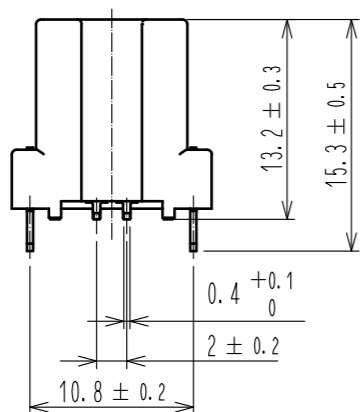
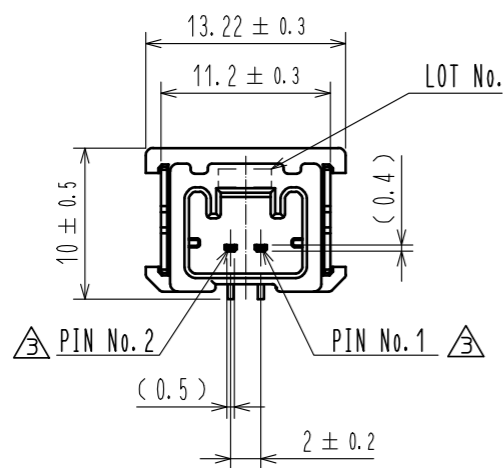
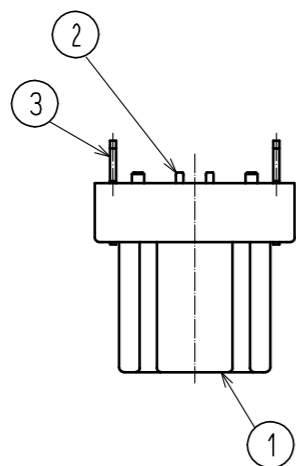
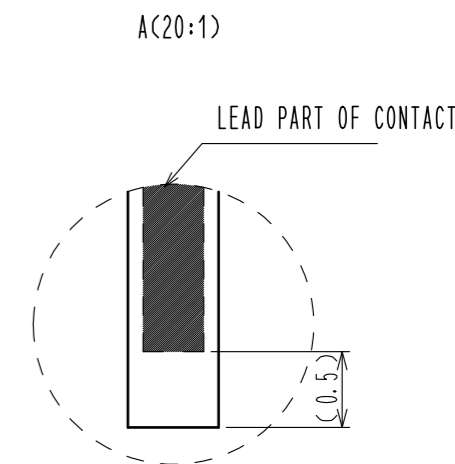
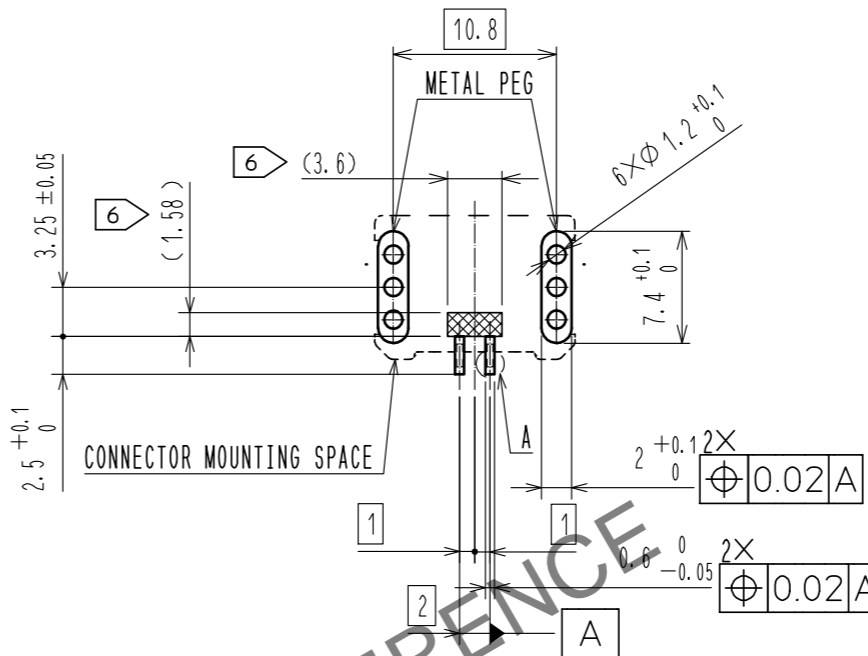

- NOTE 1. RECOMMENDED TEMPERATURE PROFILE FOR REFLOW (REFER TO RIGHT FIG.) USED REFLOW SYSTEM : IR IN THE AIR OR NITROGEN
 NO. OF CYCLES : 2 MAX
 PEAK : 250°C
 OVER 230°C : 20~40s
 PREHEAT : 150~180°C 90~120s
2. TEMPERATURE FOR SOLDERING IRON : 280~300°C WITHIN 2s
3. CO-PLANARITY SHALL BE 0.1mm MAX.
4. RECOMMENDED PCB THICKNESS IS 1.6mm.
5. RECOMMENDED SOLDER THICKNESS IS 0.15mm.
6. [Symbol] : PROHIBITED PATTERN AREA

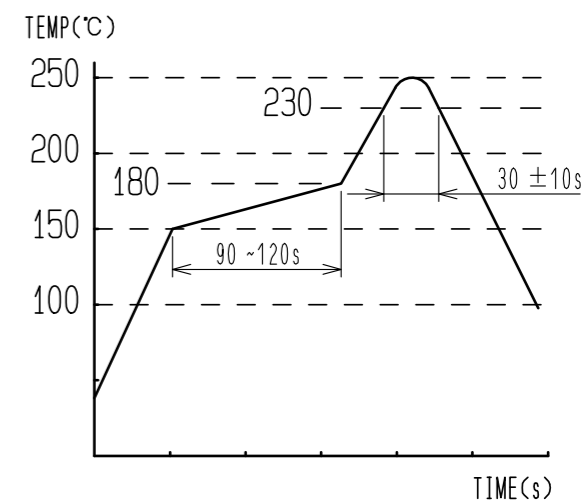

2	BRASS	SURFACE PLATING : TIN PLATING 1μm min UNDER PLATING : NICKEL 1μm min	6	POLYIMIDE	PICK & PLACE TAPE
1	PA	BLACK UL94V-0	5	POLYESTER	
			4	POLYSTYRENE	
			3	BRASS	SURFACE PLATING : TIN PLATING 1μm min UNDER PLATING : NICKEL 1μm min
NO.	MATERIAL	FINISH . REMARKS	NO.	MATERIAL	FINISH . REMARKS
UNITS mm	[Symbol]	SCALE 2 : 1	COUNT 2	DESCRIPTION OF REVISIONS DIS-T-00018184	
DESIGNED TY. IKEDA		CHECKED TY. MOGI		DATE 20230529	
APPROVED : HK. UMEHARA 20190607		DRAWING NO. EDC-368644-00-00			
CHECKED : HK. UMEHARA 20190607		PART NO. ZE05-2P-2V			
DESIGNED : YH. MAMADA 20190607		CODE NO. CL0752-2300-0-00		[Symbol] 1/2	
DRAWN : MINTAE KANG 20190607					

Oct.1.2024 Copyright 2024 HIROSE ELECTRIC CO., LTD. All Rights Reserved. In case of consideration for using Automotive equipment / device which demand high reliability, kindly contact our sales window correspondents.

Oct.1.2024 Copyright 2024 HIROSE ELECTRIC CO., LTD. All Rights Reserved.
 In case of consideration for using Automotive equipment / device which demand high reliability, kindly contact our sales window correspondents.

PACKING STYLE

REEL DIMENSION (FREE)

PACKING STYLE DRAWING

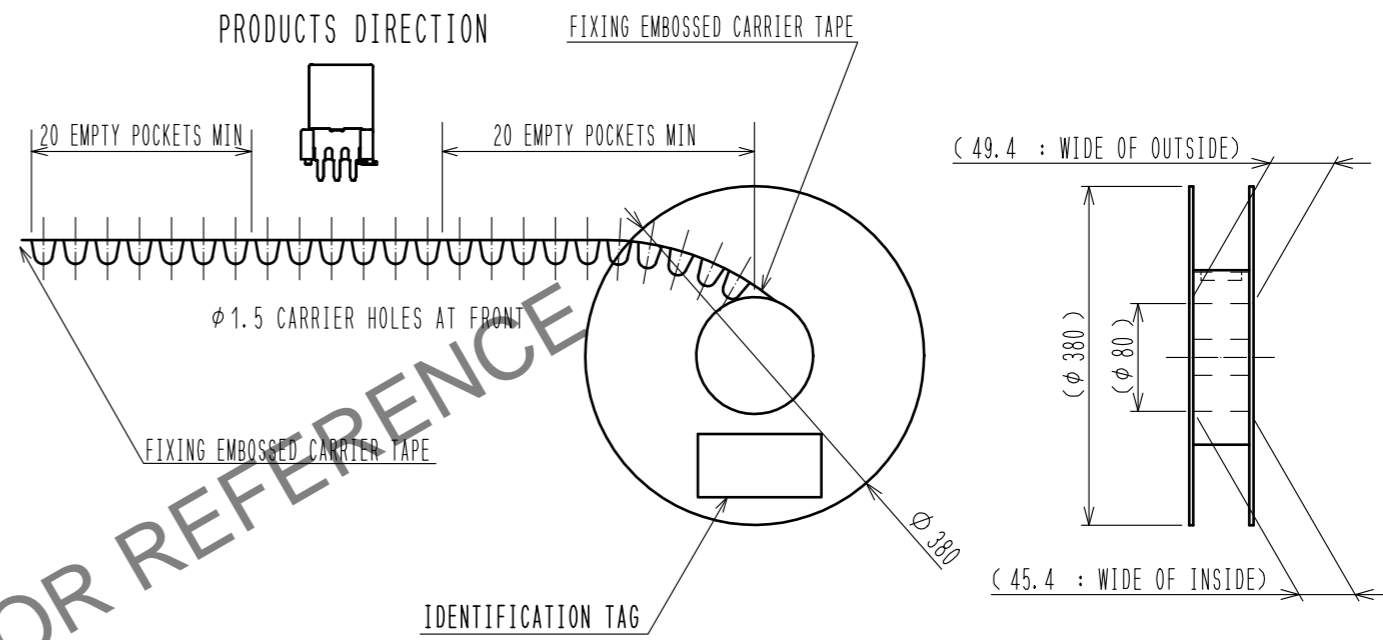
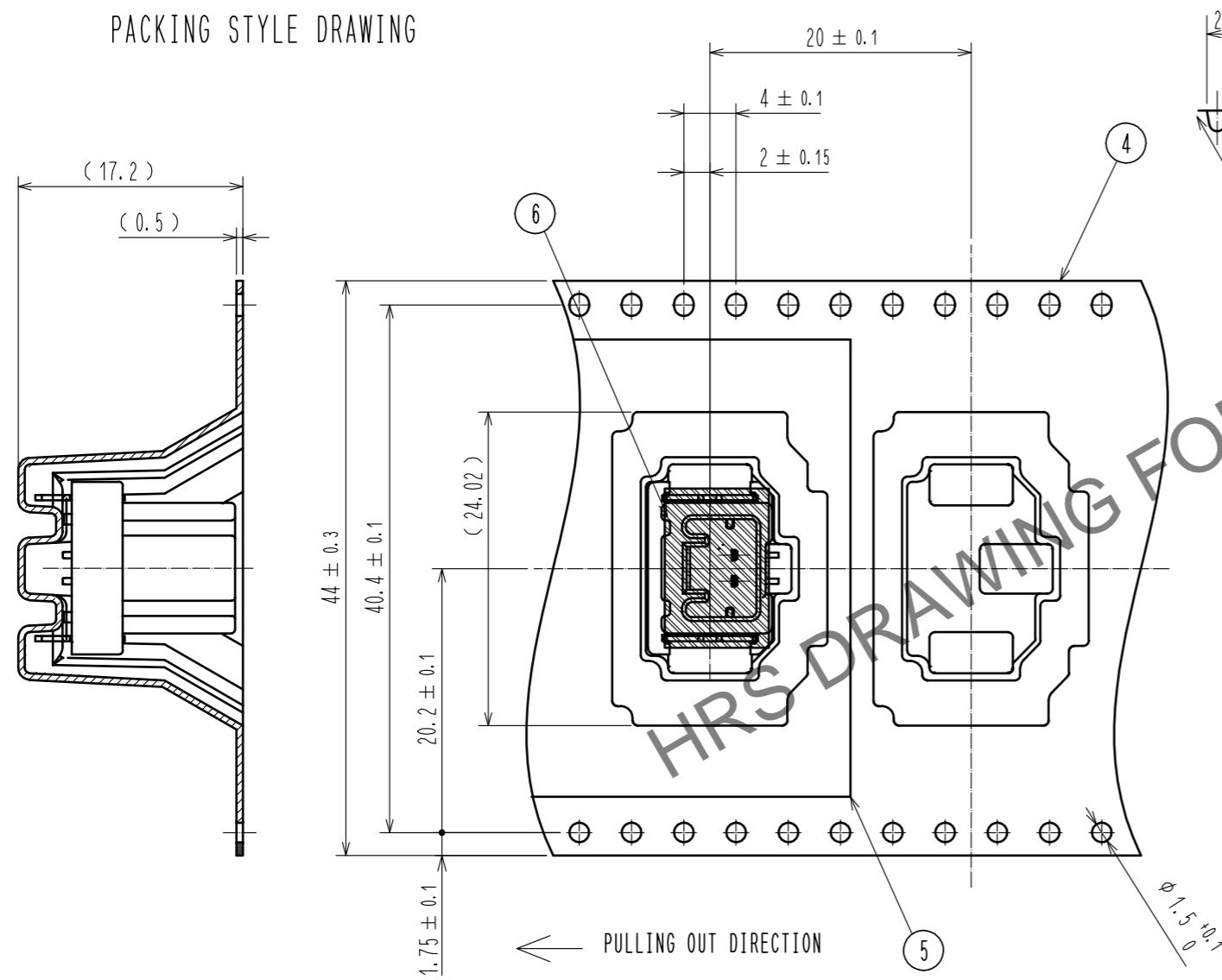

CARDBOARD DIMENSION (FREE)

W=(405) (mm)
 D=(405) (mm)
 H=(51) (mm)

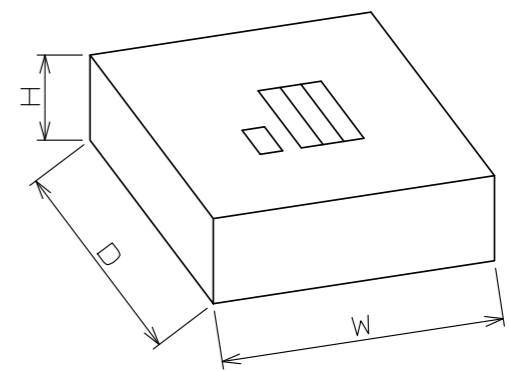

HRS	DRAWING NO.	EDC-368644-00-00	
	PART NO.	ZE05-2P-2V	
	CODE NO.	CL0752-2300-0-00	