

ELV. ROHS COMPLANT

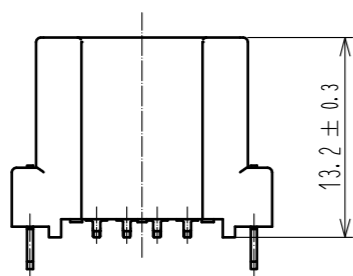

MATED CONNECTORS

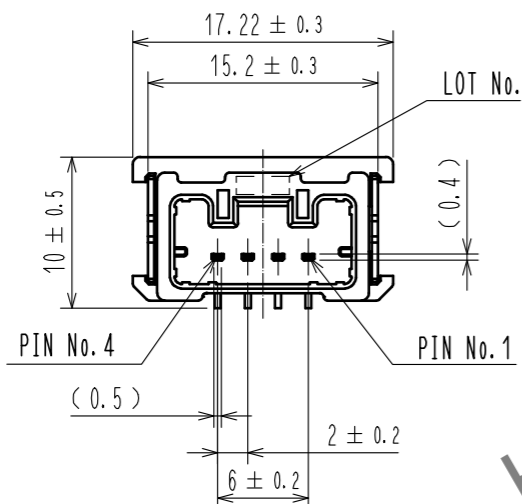
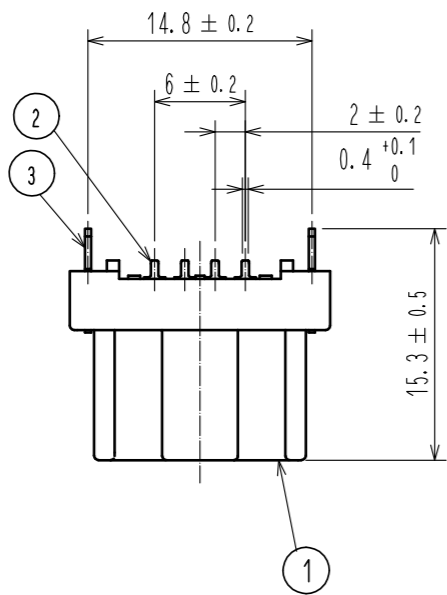
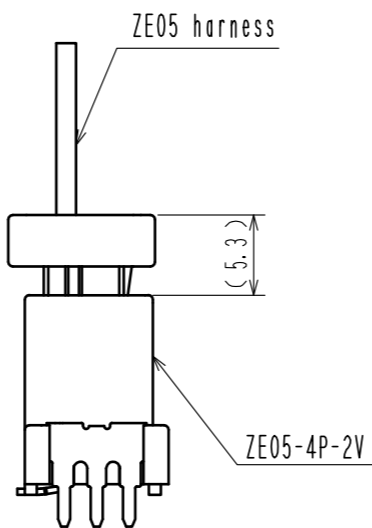

RECOMMENDED PCB PATTERN

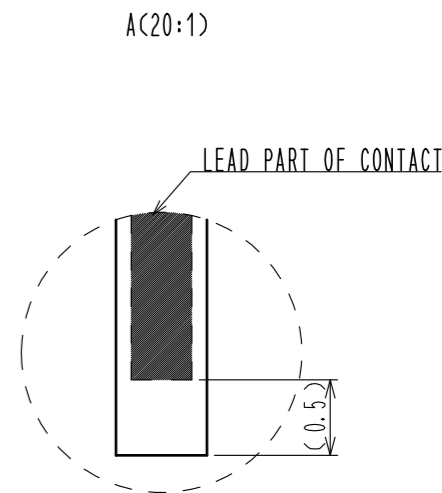
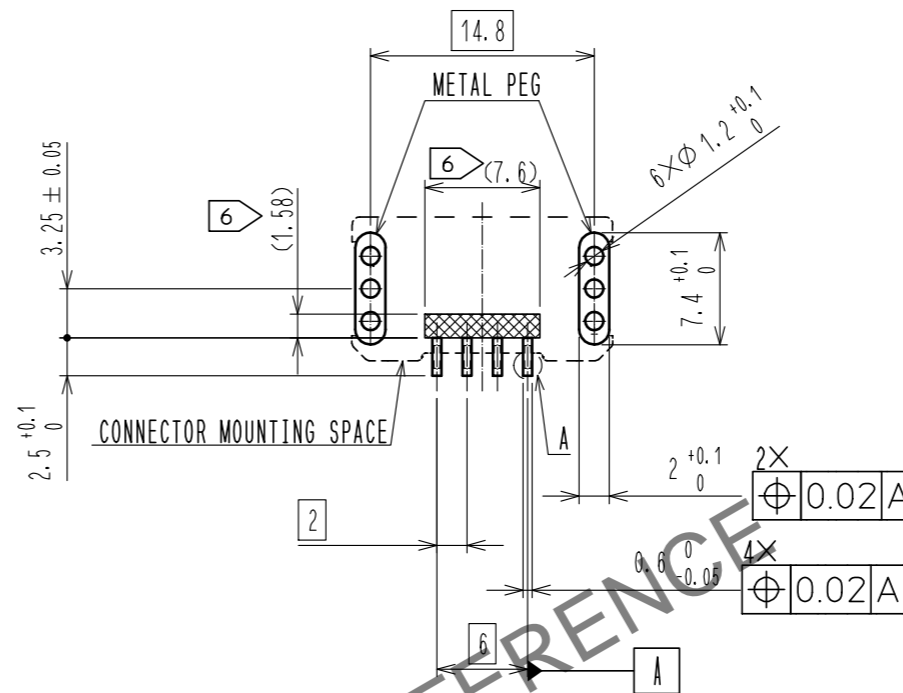

HRS DRAWING FOR REFERENCE

- NOTE 1. RECOMMENDED TEMPERATURE PROFILE FOR REFLOW (REFER TO RIGHT FIG.) USED REFLOW SYSTEM : IR IN THE AIR OR NITROGEN
 NO. OF CYCLES : 2 MAX
 PEAK : 250°C
 OVER 230°C : 20~40s
 PREHEAT : 150~180°C 90~120s
2. TEMPERATURE FOR SOLDERING IRON : 280~300°C WITHIN 2s
3. CO-PLANARITY SHALL BE 0.1mm MAX.
4. RECOMMENDED PCB THICKNESS IS 1.6mm.
5. RECOMMENDED SOLDER THICKNESS IS 0.15mm.
- 6 > [Hatched Area] : PROHIBITED PATTERN AREA

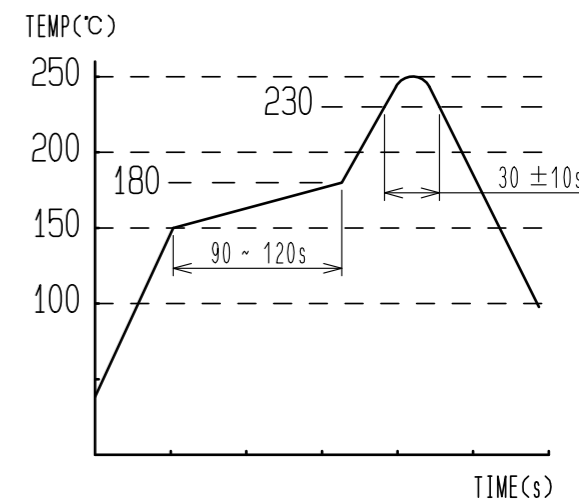

2	BRASS	SURFACE PLATING : TIN PLATING 1µm min UNDER PLATING : NICKEL 1µm min	6	POLYIMIDE	PICK & PLACE TAPE
1	PA	BLACK UL94V-0	5	POLYESTER	
			4	POLYSTYRENE	
			3	BRASS	SURFACE PLATING : TIN PLATING 1µm min UNDER PLATING : NICKEL 1µm min
NO.	MATERIAL	FINISH . REMARKS	NO.	MATERIAL	FINISH . REMARKS
UNITS mm		SCALE 2 : 1	COUNT 2	DESCRIPTION OF REVISIONS DIS-T-00006748	DESIGNED YH.MAMADA
HRS HIROSE ELECTRIC CO., LTD.		APPROVED : HK. UMEHARA 20190607	DRAWING NO. EDC-368645-00-00		
		CHECKED : HK. UMEHARA 20190607	PART NO. ZE05-4P-2V		
		DESIGNED : YH. MAMADA 20190607	CODE NO. CL752-2301-0-00		
		DRAWN : MINTAE KANG 20190607	DATE 20200920		

Oct.1.2024 Copyright 2024 HIROSE ELECTRIC CO., LTD. All Rights Reserved. In case of consideration for using Automotive equipment / device which demand high reliability, kindly contact our sales window correspondents.

Oct.1.2024 Copyright 2024 HIROSE ELECTRIC CO., LTD. All Rights Reserved.
 In case of consideration for using Automotive equipment / device which demand high reliability, kindly contact our sales window correspondents.

PACKING STYLE

REEL DIMENSION (FREE)

PACKING STYLE DRAWING

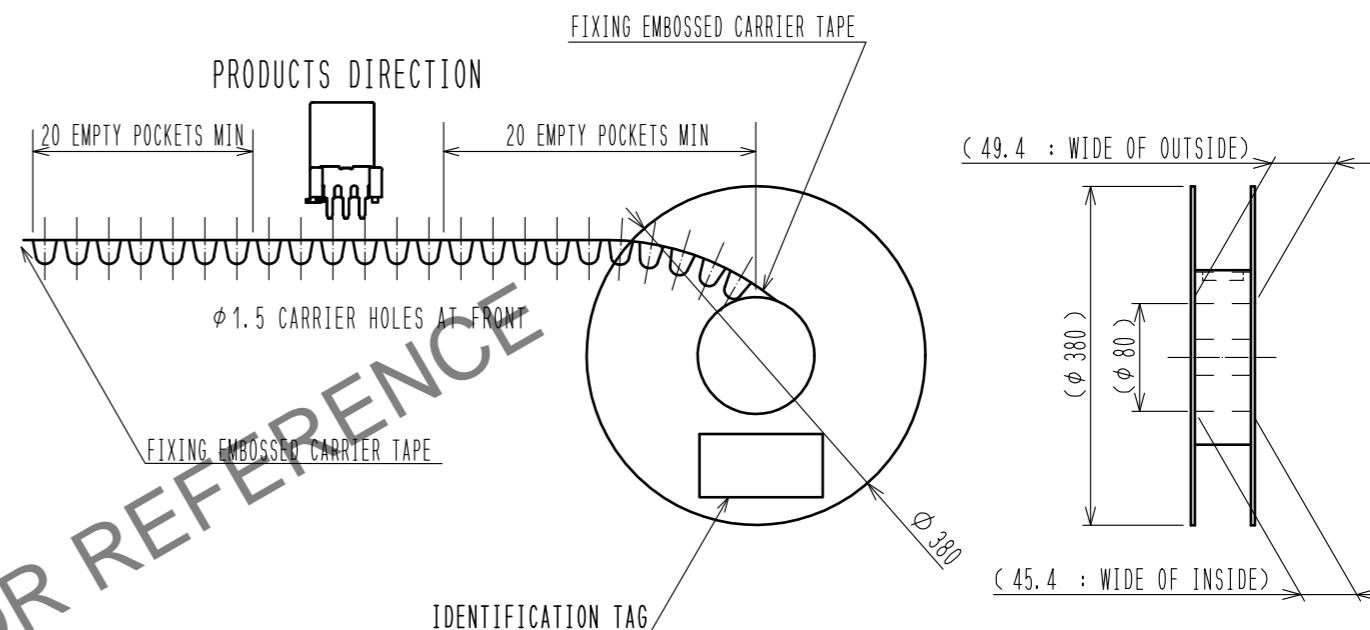
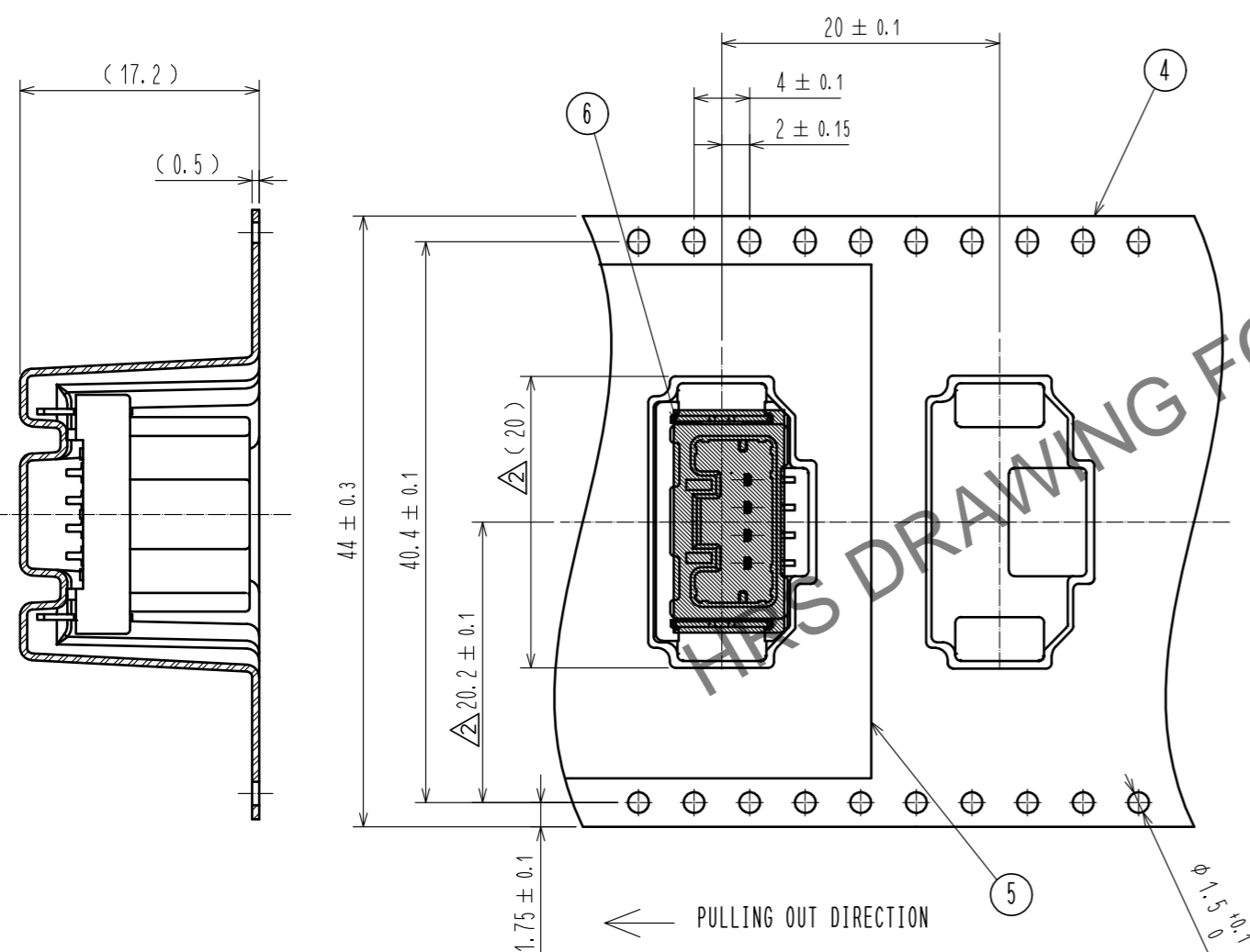

250 PCS/REEL

CARDBOARD DIMENSION (FREE)

W=(405) (mm)
 D=(405) (mm)
 H=(51) (mm)

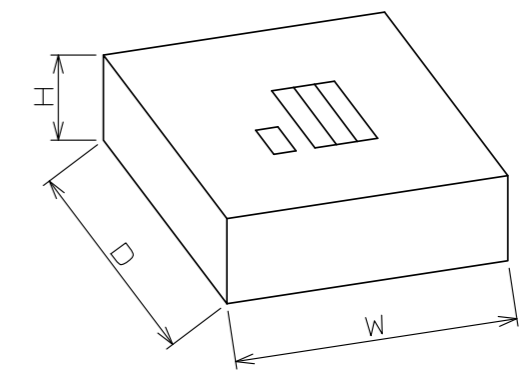

HRS	DRAWING NO.	EDC-368645-00-00	
	PART NO.	ZE05-4P-2V	
	CODE NO.	CL752-2301-0-00	