

ELV. RoHS COMPLIANT

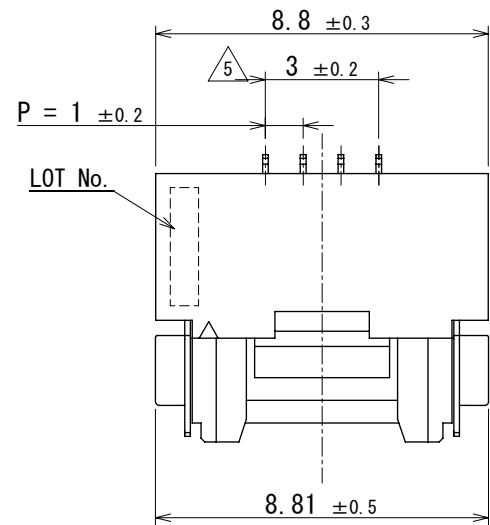

MATED CONNECTORS (FREE)

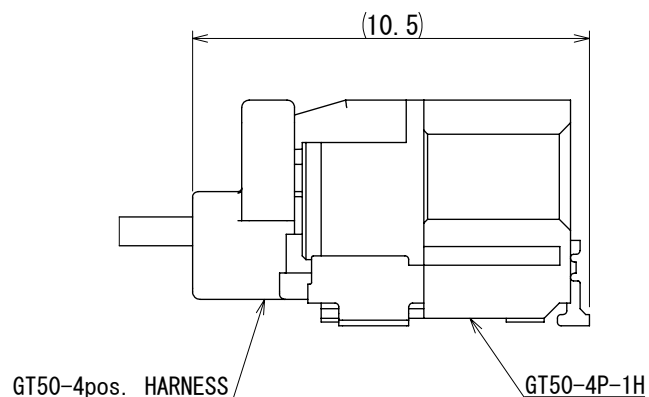

RECOMMENDED PCB PATTERN (FREE)
OPEN AREA RATIO : 100%

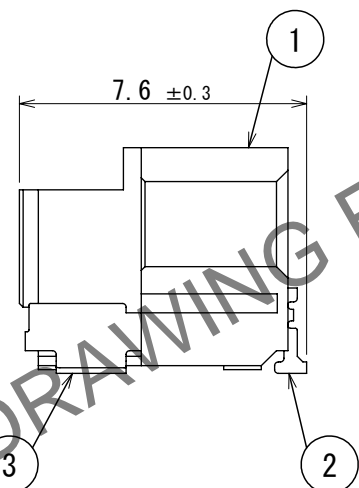
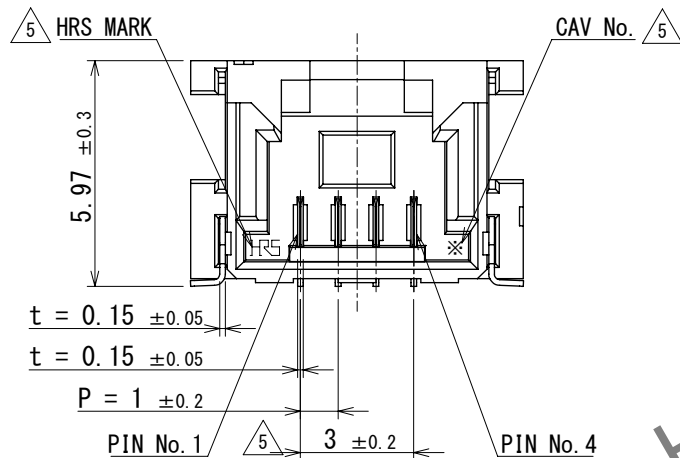
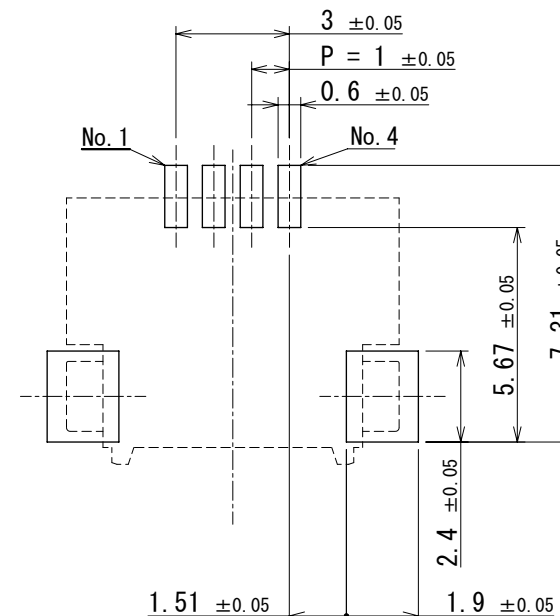

HRS DRAWING FOR REFERENCE

NOTE 1. RECOMMENDED TEMPERATURE PROFILE FOR REFLOW
(REFER TO RIGHT FIG.)
USED REFLOW SYSTEM

NO. OF CYCLES : 1R IN THE AIR OR NITROGEN
PEAK : 250°C
OVER 230°C : 20~40s
PREHEAT : 150~180°C
90~120s

△ 2. TEMPERATURE FOR SOLDERING IRON : 350~380°C WITHIN 5s
3. CO-PLANARITY : 0.1mm MAX
4. RECOMMENDED SOLDER THICKNESS : 0.10mm

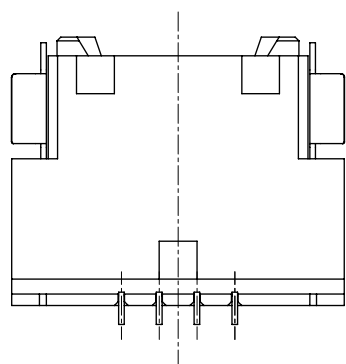
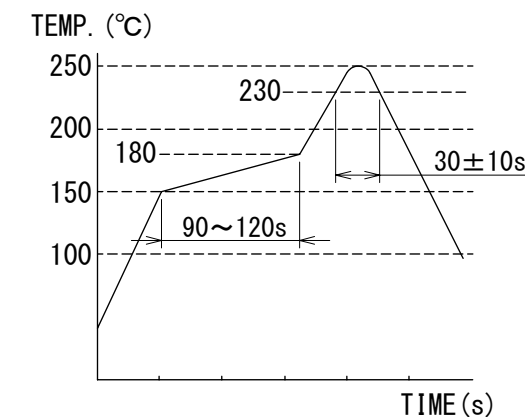

3	BRASS	TIN PLATING	6	POLYSTYRENE									
2	BRASS	Au PLATING	5	POLYESTER									
1	LCP	BLACK	4	POLYSTYRENE									
NO.	MATERIAL	FINISH	REMARKS	NO.	MATERIAL	FINISH	REMARKS						
UNITS	mm	SCALE	5:1	COUNT	6	DESCRIPTION OF REVISIONS	DIS-T-00020330	DESIGNED	RS. TAKAGI	CHECKED	HH. TSUKUMO	DATE	2024. 03. 05
APPROVED : HK. UMEHARA		2021. 06. 24		DRAWING NO.		EDC-392587-00-00							
CHECKED : OM. MIYAMOTO		2021. 06. 24		PART NO.		GT50-4P-1H							
DESIGNED : YT. TAKANASHI		2021. 06. 24		CODE NO.		CL0760-1004-0-00							
DRAWN : YT. TAKANASHI		2021. 06. 24											

Dec.1.2024 Copyright 2024 HIROSE ELECTRIC CO., LTD. All Rights Reserved. In case of consideration for using Automotive equipment / device which demand high reliability, kindly contact our sales window correspondents.

Dec.1.2024 Copyright 2024 HIROSE ELECTRIC CO., LTD. All Rights Reserved.
 In case of consideration for using Automotive equipment / device which demand high reliability, kindly contact our sales window correspondents.

PACKING STYLE (FREE)

REEL DIMENSION

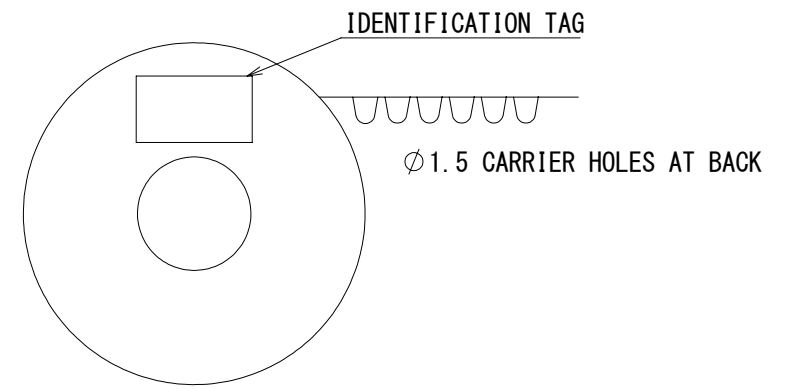

PACKING STYLE DRAWING

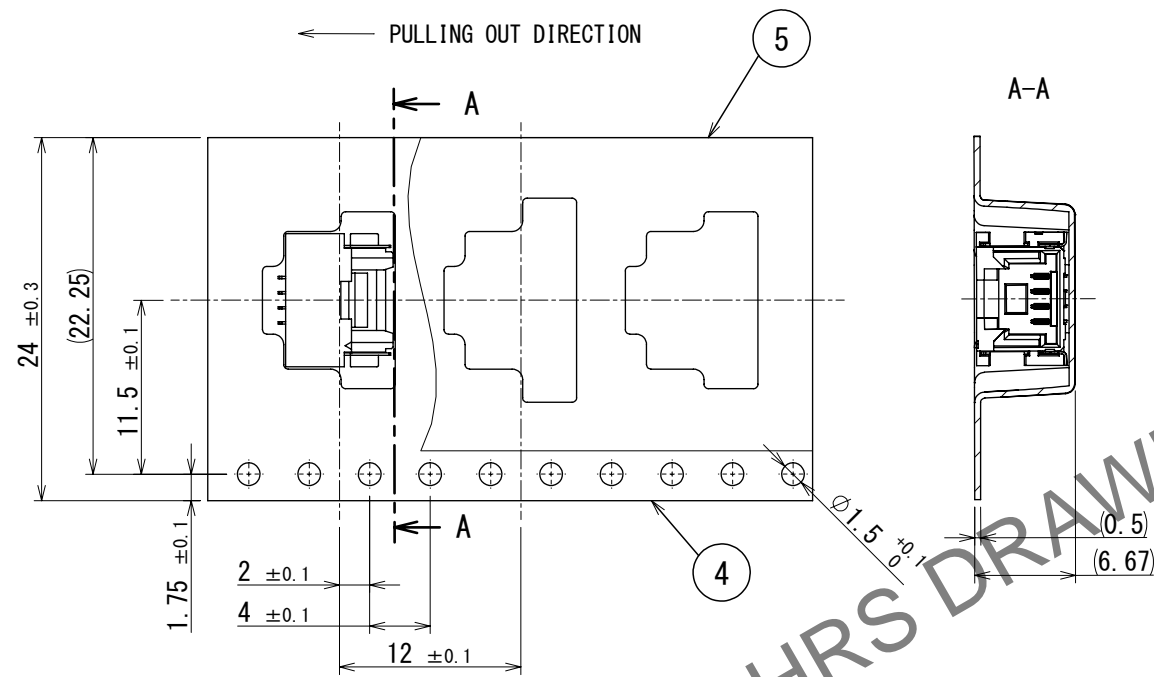

PRODUCTS DIRECTION

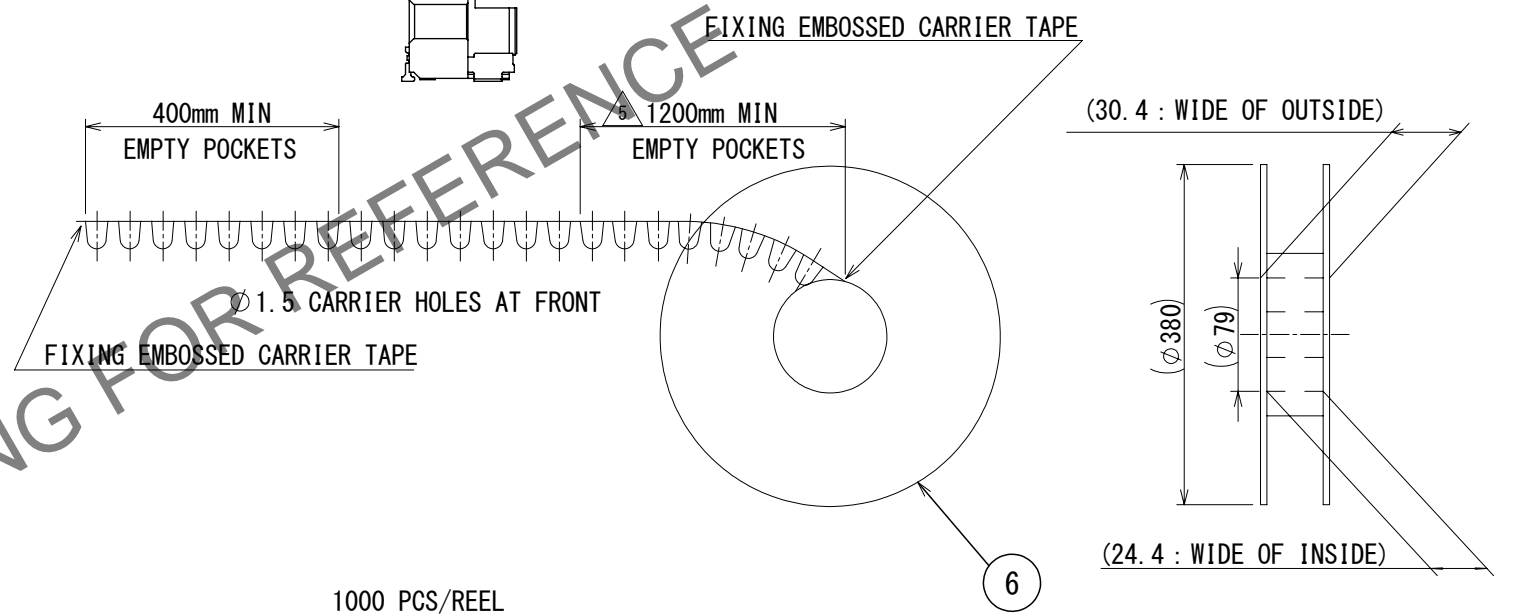
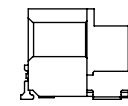

1000 PCS/REEL

※Embossed pocket has a different shape to prevent overlapping, and the drawing shows a representative shape.

CARDBOARD DIMENSION

W = (405) (mm)
 D = (405) (mm)
 H = (31) (mm)

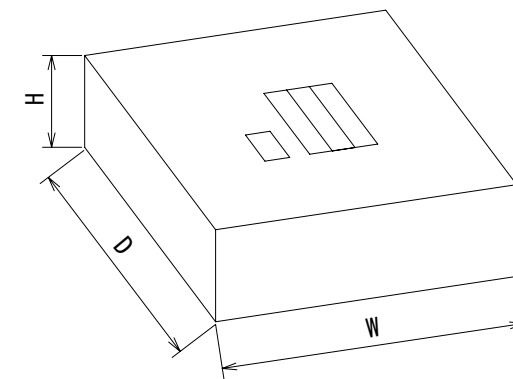

HRS	DRAWING NO.	EDC-392587-00-00
	PART NO.	GT50-4P-1H
	CODE NO.	CL0760-1004-0-00
		5/2