

Dec.1.2024 Copyright 2024 HIROSE ELECTRIC CO., LTD. All Rights Reserved.
In case of consideration for using Automotive equipment / device which demand high reliability, kindly contact our sales window correspondents.

ELV. RoHS COMPLIANT

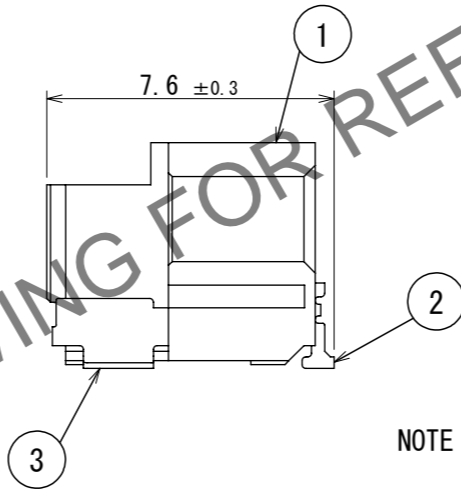

- NOTE 1. RECOMMENDED TEMPERATURE PROFILE FOR REFLOW (REFER TO RIGHT FIG.) USED REFLOW SYSTEM**
- NO. OF CYCLES : 2 MAX
 - PEAK : 250°C
 - OVER 230°C : 20~40s
 - PREHEAT : 150~180°C
 - 90~120s
- △ 2. TEMPERATURE FOR SOLDERING IRON : 350~380°C WITHIN 5s**
- 3. CO-PLANARITY : 0.1mm MAX**
- 4. RECOMMENDED SOLDER THICKNESS : 0.10mm**

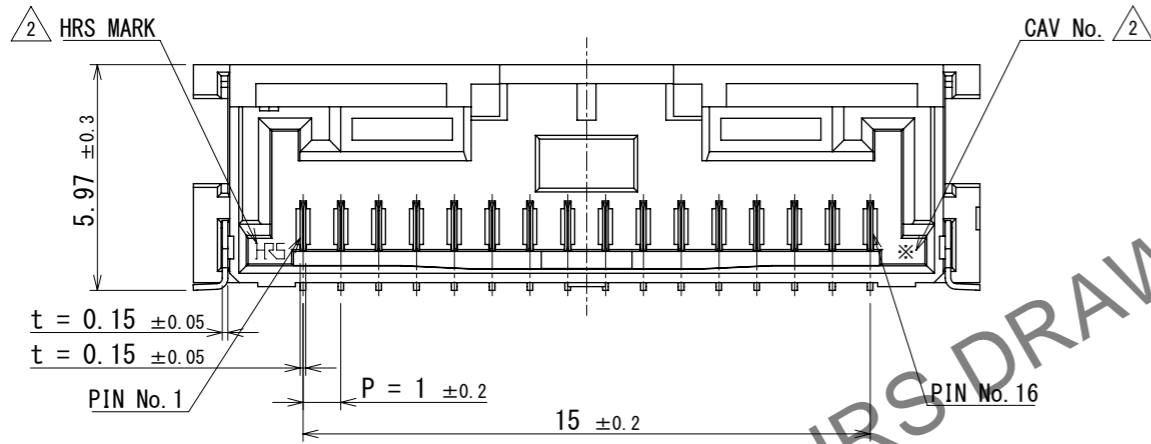
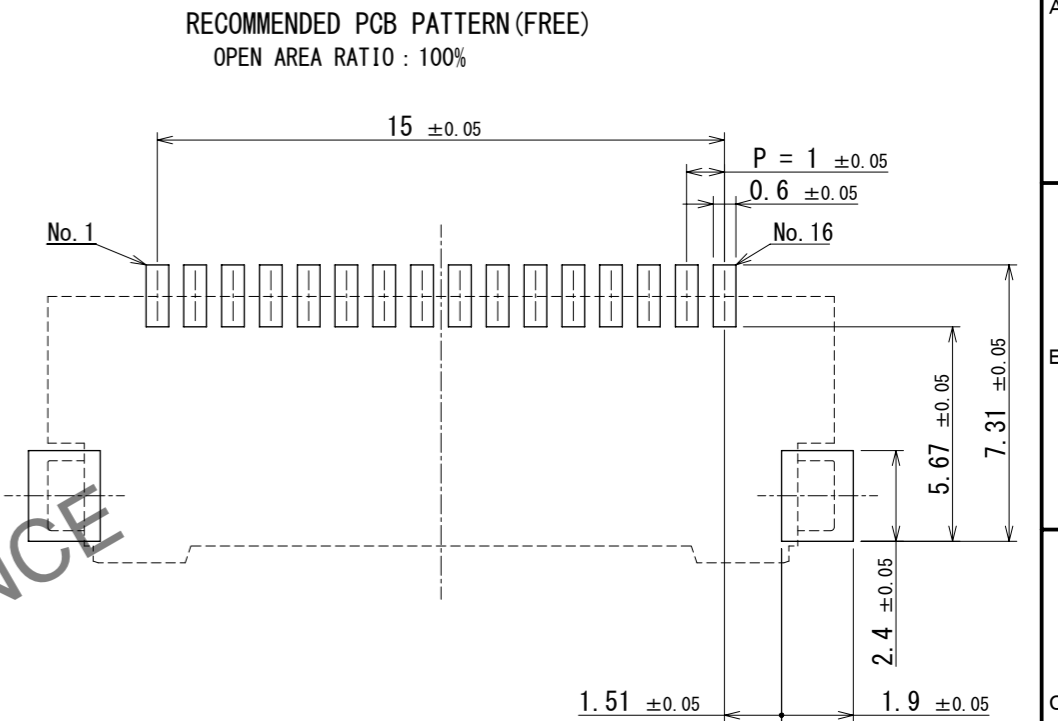
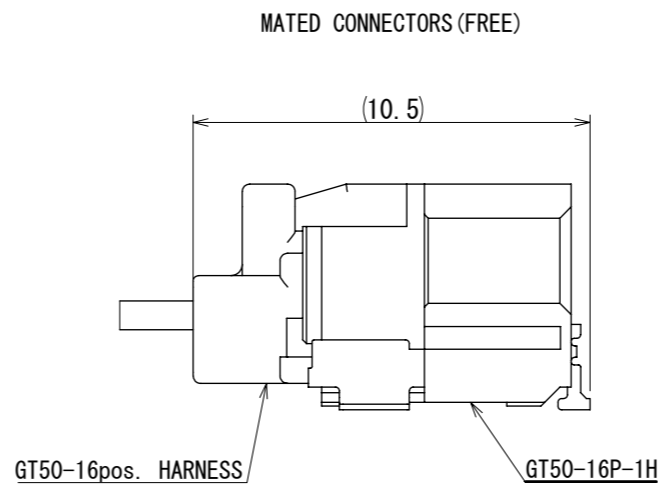
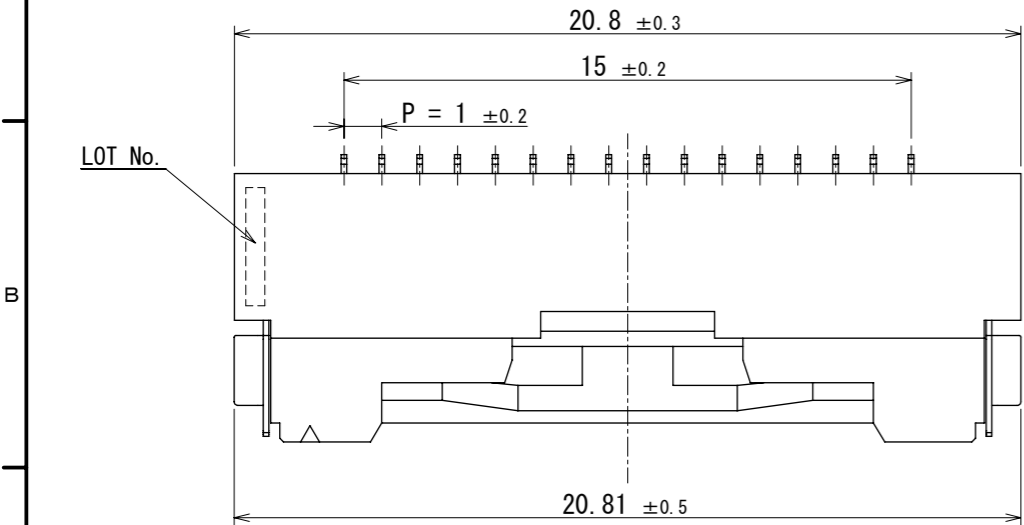
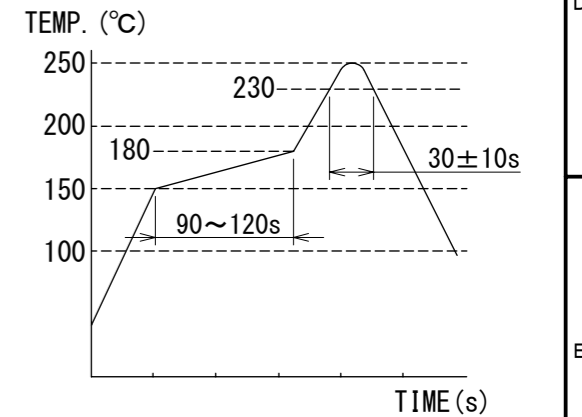

3	BRASS	TIN PLATING	6	POLYSTYRENE			
2	BRASS	Au PLATING	5	POLYESTER			
1	LCP	BLACK	4	POLYSTYRENE			
NO.	MATERIAL	FINISH	REMARKS	NO.	MATERIAL	FINISH	REMARKS
UNITS	mm	SCALE	5:1	COUNT	△ 5	DESCRIPTION OF REVISIONS	DIS-T-00020330
DESIGNED		RS. TAKAGI		CHECKED		HH. TSUKUMO	
DATE		2024. 03. 05		APPROVED		HK. UMEHARA 2020. 12. 24	
DRAWING NO.		EDC-392595-00-00		PART NO.		GT50-16P-1H	
CODE NO.		CL0760-1012-0-00		DRAWN		YT. TAKANASHI 2020. 12. 22	

Dec.1.2024 Copyright 2024 HIROSE ELECTRIC CO., LTD. All Rights Reserved.
 In case of consideration for using Automotive equipment / device which demand high reliability, kindly contact our sales window correspondents.

PACKING STYLE (FREE)

A
B
C
D
E
F

REEL DIMENSION

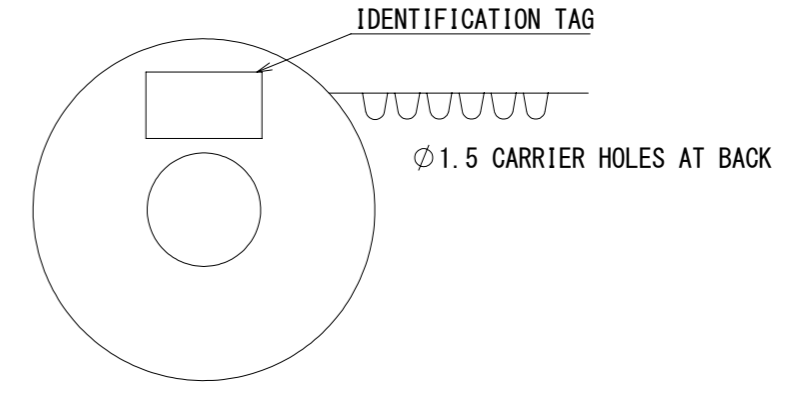

PACKING STYLE DRAWING

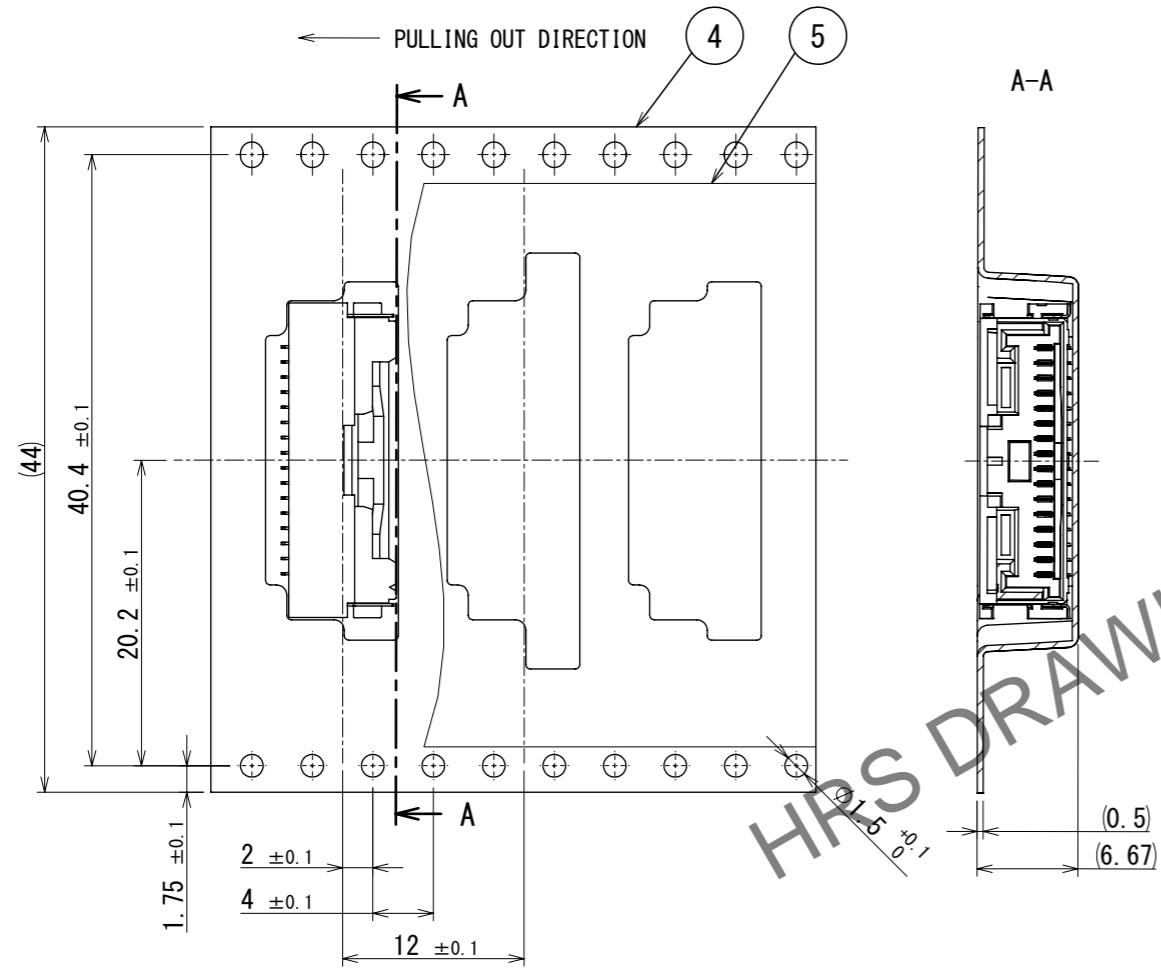

PRODUCTS DIRECTION

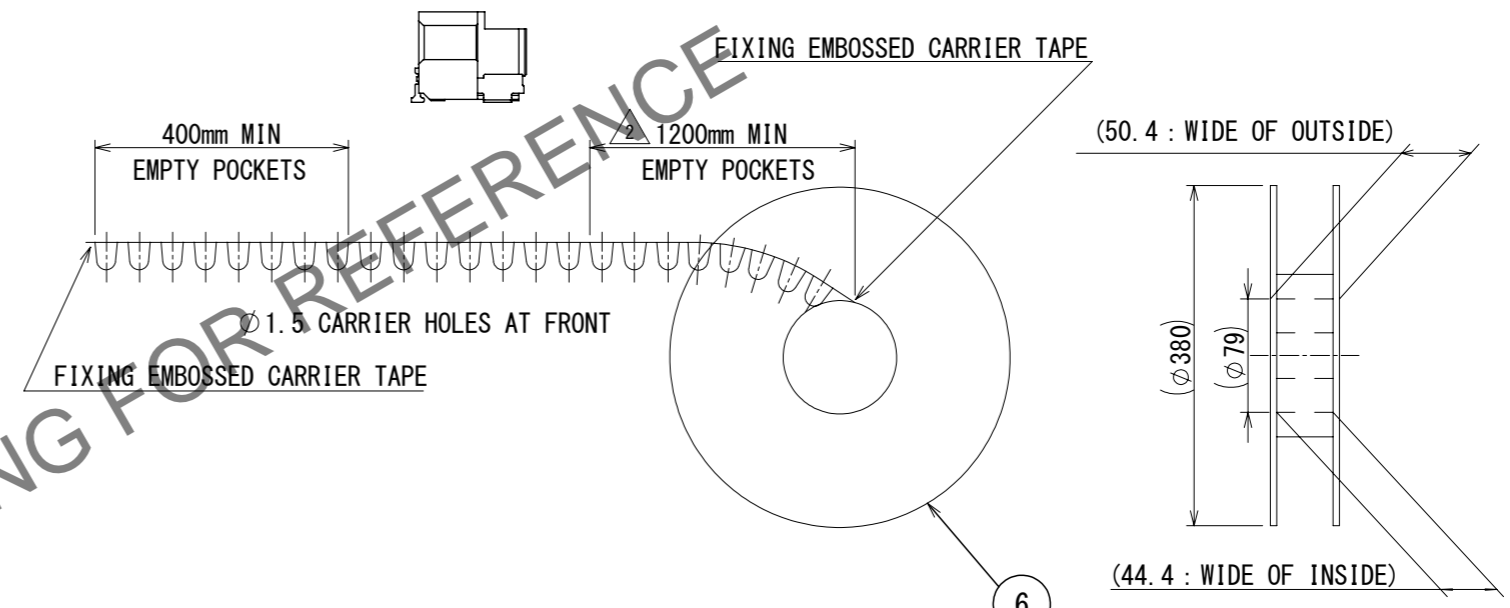

1000 PCS/REEL

CARDBOARD DIMENSION

W = (405) (mm)
 D = (405) (mm)
 H = (51) (mm)

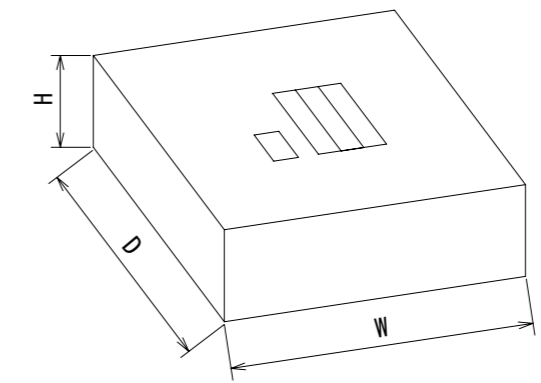

△※ Embossed pocket has a different shape to prevent overlapping, and the drawing shows a representative shape.

HRS	DRAWING NO.	EDC-392595-00-00	2/2
	PART NO.	GT50-16P-1H	
	CODE NO.	CL0760-1012-0-00	