

Jan.1.2025 Copyright 2025 HIROSE ELECTRIC CO., LTD. All Rights Reserved.
 In case of consideration for using Automotive equipment / device which demand high reliability, kindly contact our sales window correspondents.

ELV, RoHS COMPLIANT

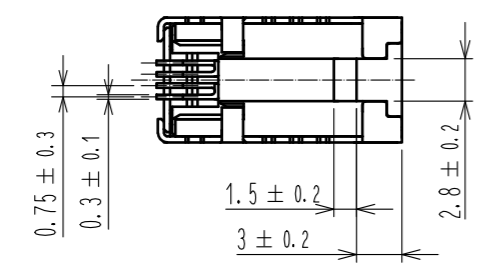

MATED CONNECTORS

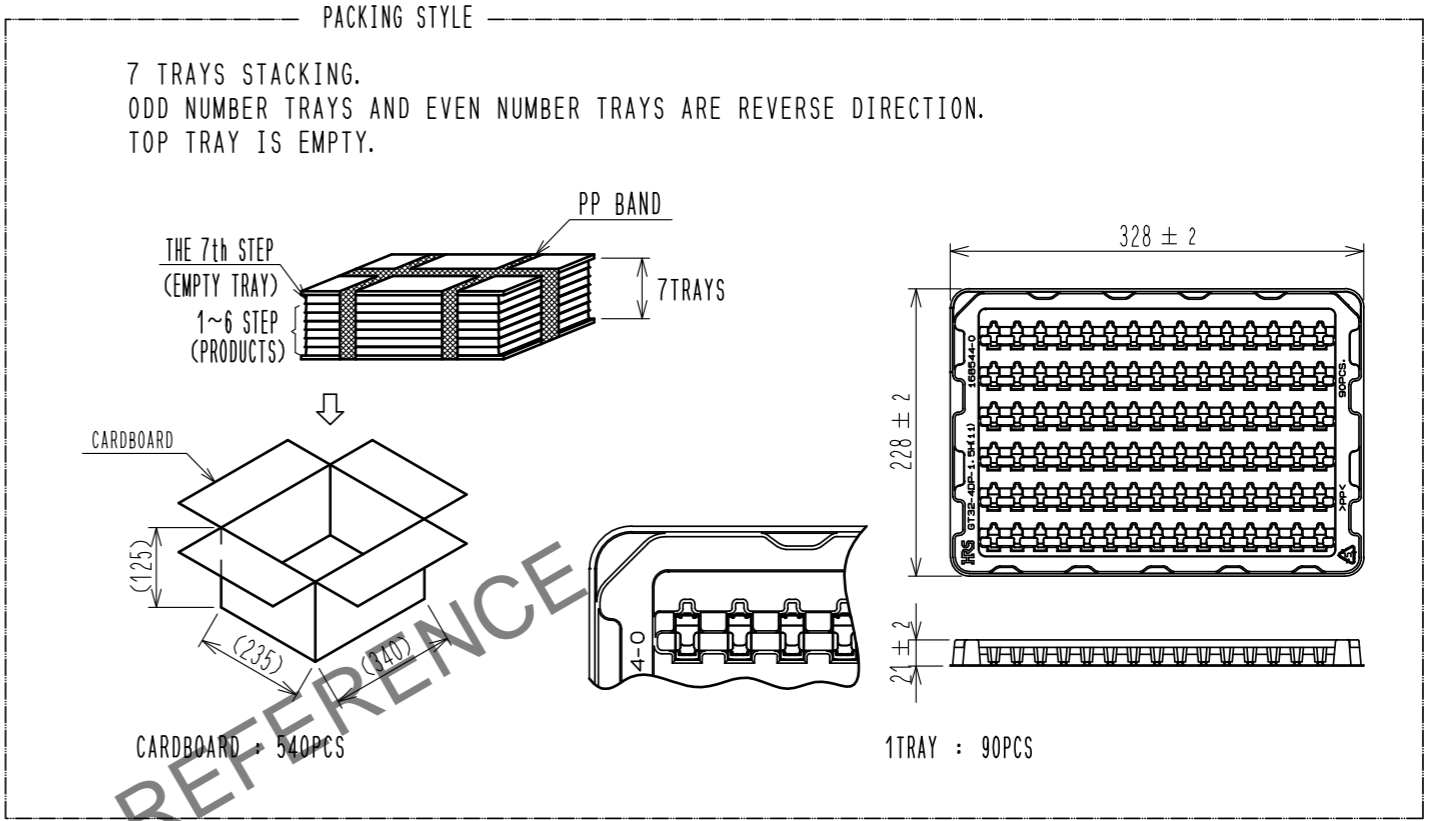
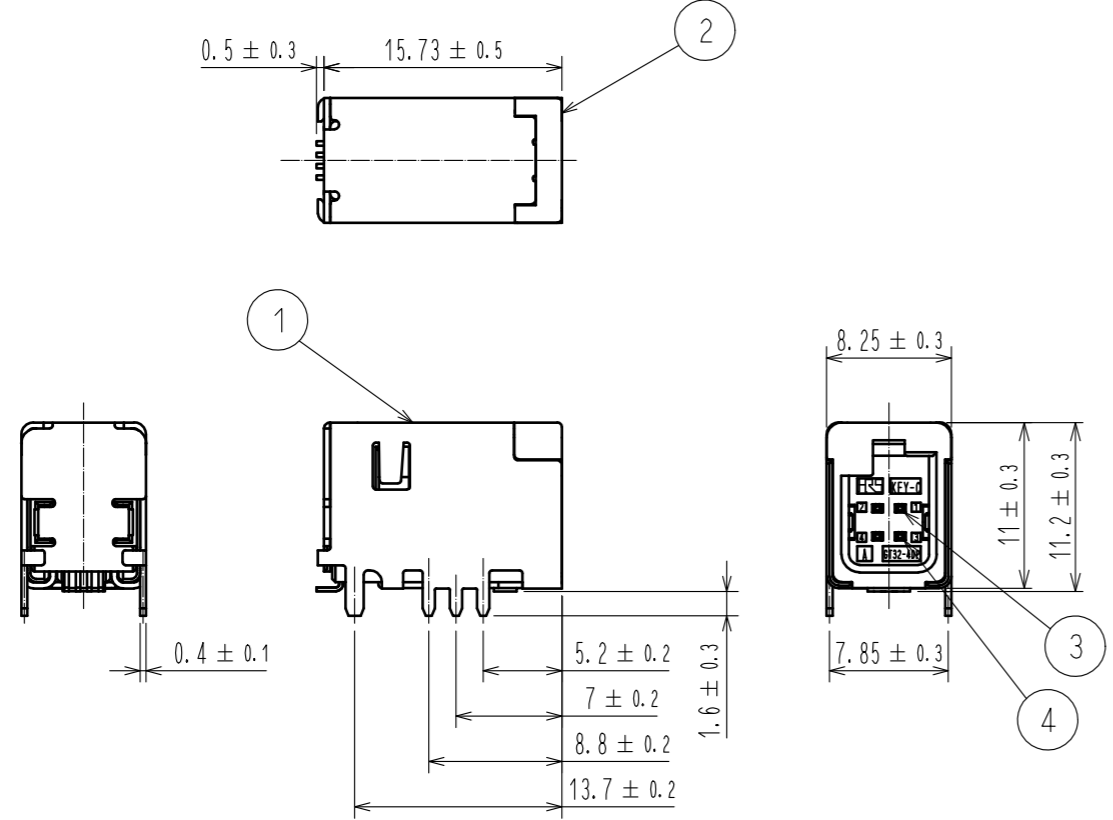
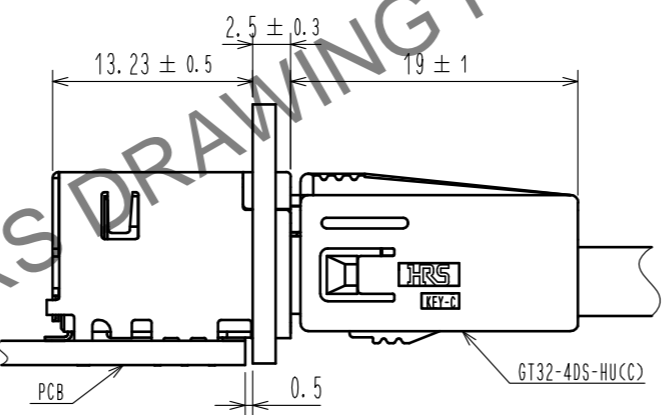

RECOMMENDED PCB LAYOUT (3:1)

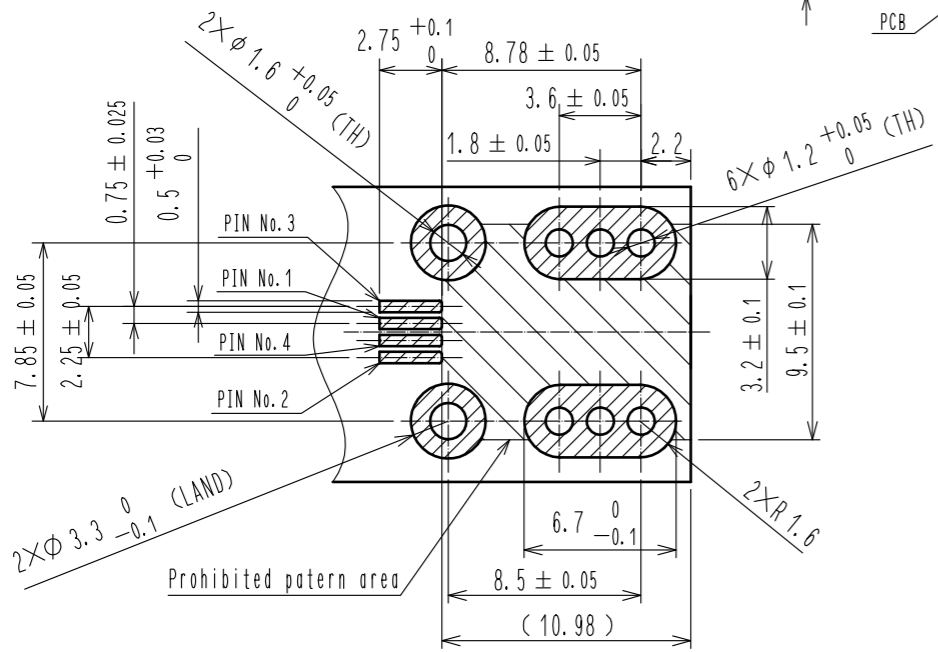

RECOMMENDED PANEL CUTOUT

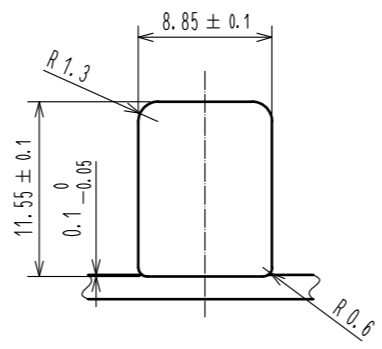

NOTES

- RECOMMENDED REFLOW PROFILE (SEE RIGHT GRAPH)
 CYCLE TIME: UP TO 2 CYCLES OF REFLOW SOLDERING ARE POSSIBLE UNDER THE CONDITIONS. PROVIDED THAT THERE IS A RETURN TO NORMAL TEMPERATURE BETWEEN THE FIRST AND SECOND CYCLE.
 PEAK TEMPERATURE: 250°C
 230°C MIN. FOR 20 TO 40 SECONDS.
 PREHEATING AREA 150~180°C FOR 60 TO 120 SECONDS.
- HAND SOLDERING: 280~300°C, 2SECONDS MAX.
- CONTACT COPLANARITY: 0.1mm MAX.
- RECOMMENDED THICKNESS OF PCB: 1.6mm
- RECOMMENDED THICKNESS OF SOLDERING PASTE: 0.12mm

TEMP. (°C)

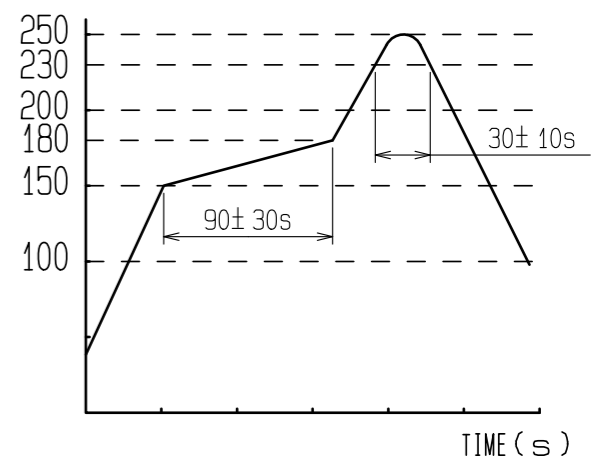

2	PA	BLUE	4	BRASS	TIN PLATING
1	COPPER ALLOY	TIN PLATING	3	BRASS	TIN PLATING
NO.	MATERIAL	FINISH . REMARKS	NO.	MATERIAL	FINISH . REMARKS
UNITS mm		SCALE 2 : 1	COUNT 	DESCRIPTION OF REVISIONS	DESIGNED
APPROVED : AR. SHIRAI 17.03.14			DRAWING NO. EDC-361829-11-01		
CHECKED : TH. MIZUGUCHI 17.03.13			PART NO. GT32-4DP-1.5H(C)(11)		
DESIGNED : TS. KUBOTA 17.03.13			CODE NO. CL782-0063-9-11		
DRAWN : TS. KUBOTA 17.03.13			DATE		
			1/1		