

Jan.1.2025 Copyright 2025 HIROSE ELECTRIC CO., LTD. All Rights Reserved.  
In case of consideration for using Automotive equipment / device which demand high reliability, kindly contact our sales window correspondents.

RoHS, ELV COMPLIANT

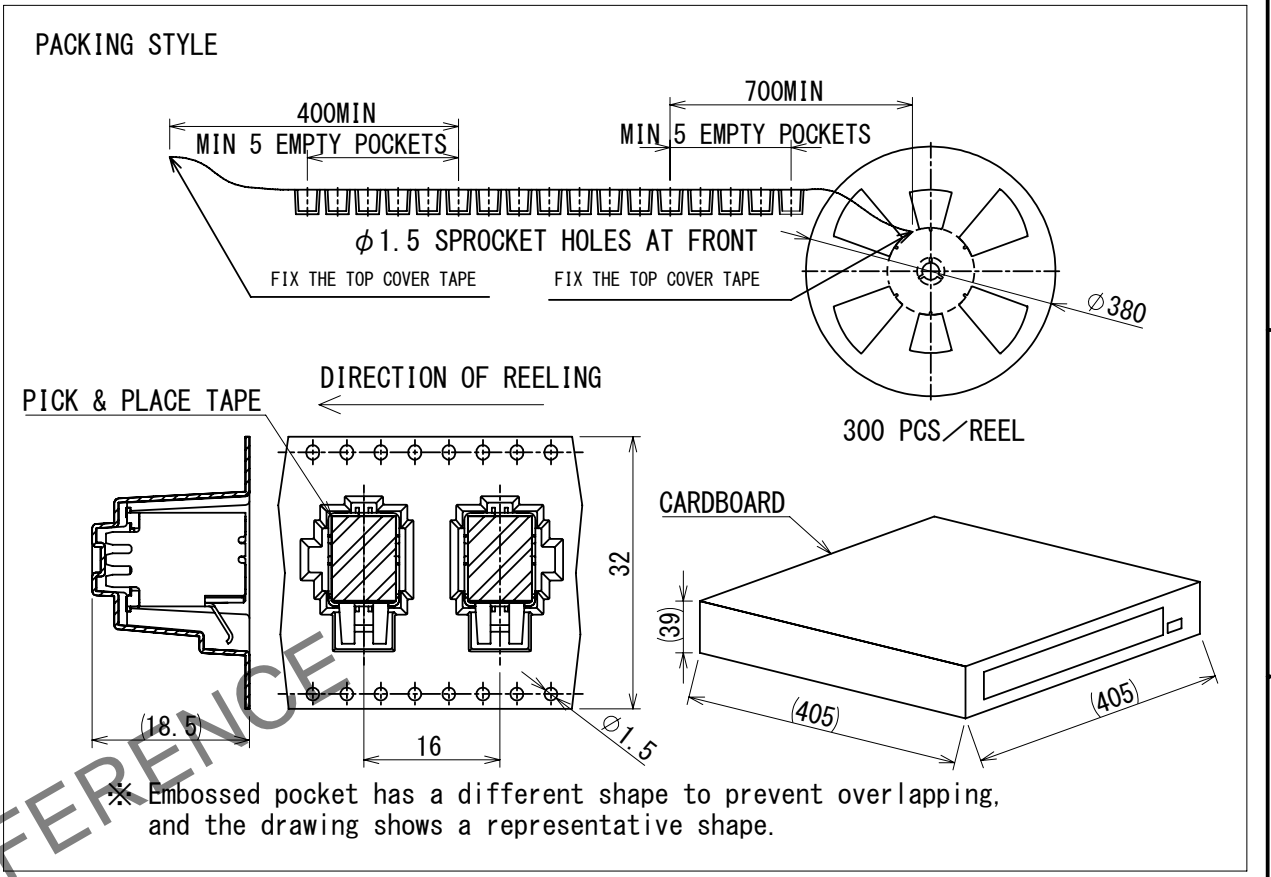

MATED CONNECTORS

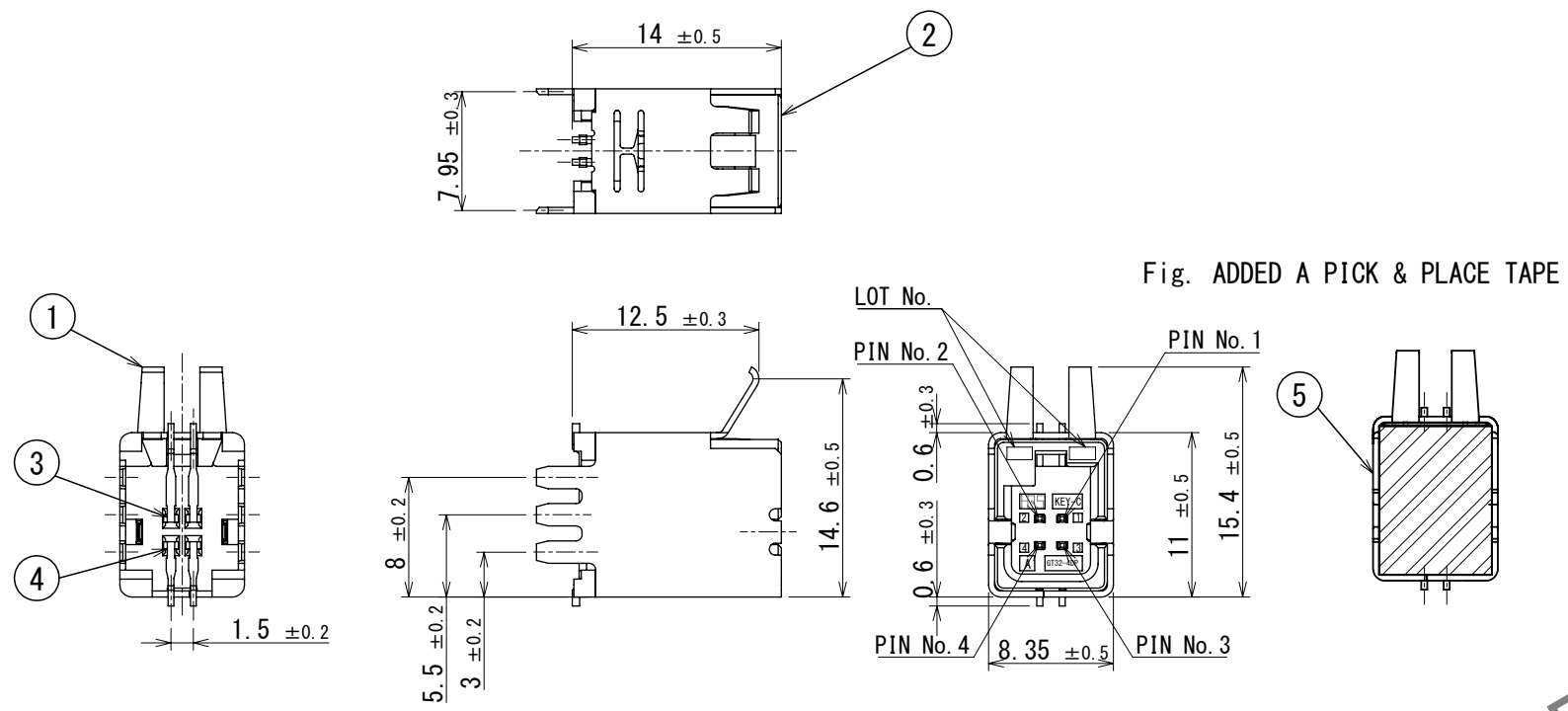
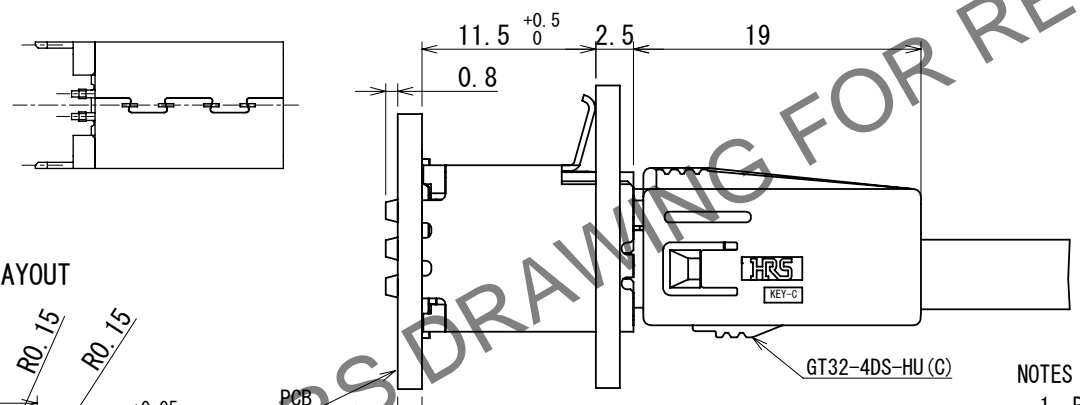

RECOMMENDED PCB LAYOUT (4:1)

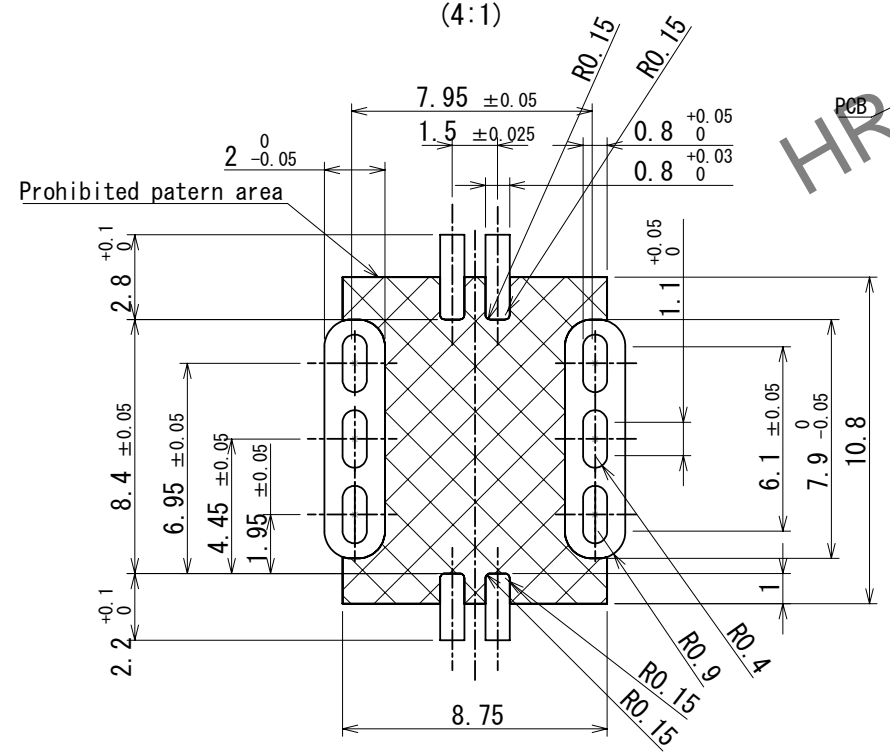

RECOMMENDED PANEL CUTOUT

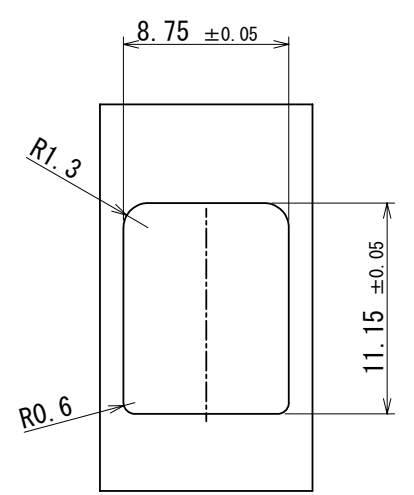

NOTES

1. RECOMMENDED REFLOW PROFILE (SEE RIGHT GRAPH)  
CYCLE TIME: UP TO 2 CYCLES OF REFLOW SOLDERING ARE POSSIBLE UNDER THE CONDITIONS, PROVIDED THAT THERE IS A RETURN TO NOMAL TEMPERATURE BETWEEN THE FIRST AND SECOND CYCLE.  
PEAK TEMPERATURE: 250°C  
230°C MIN, FOR 20 TO 40 SECONDS.  
PREHEATING AREA 150~180°C FOR 60 TO 120 SECONDS.
2. HAND SOLDERING: 280~300°C, 2SECONDS MAX.
3. CONTACT COPLANARITY: 0.1mm MAX.
4. RECOMMENDED THICKNESS OF PCB: 1.6mm
5. RECOMMENDED THICKNESS OF SOLDERING PASTE: 0.12mm

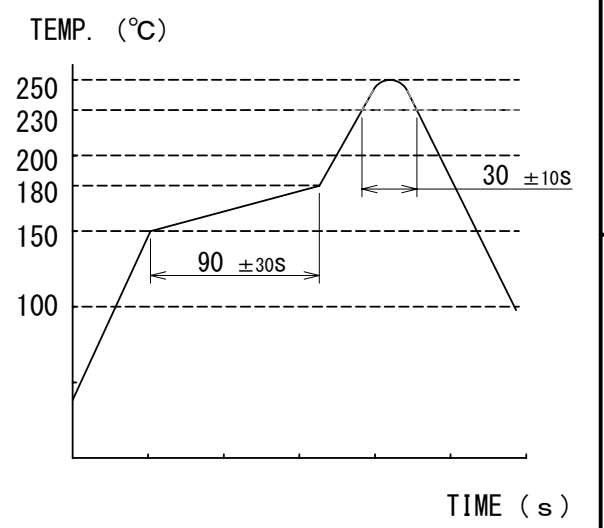

3	BRASS	TIN PLATING							
2	PA	BLUE	5	POLYIMIDE	PICK & PLACE TAPE				
1	COPPER ALLOY	TIN PLATING	4	BRASS	TIN PLATING				
NO.	MATERIAL	FINISH	REMARKS	NO.	MATERIAL	FINISH	REMARKS		
UNITS	mm	SCALE	2:1	COUNT	0	DESCRIPTION OF REVISIONS	DESIGNED	CHECKED	DATE
						DIS-T-00018485	KN. YANAGIMOTO	EJ. WAKATSUKI	2023. 10. 19
		APPROVED :	AR. SHIRAI	2018. 09. 07	DRAWING NO.		EDC-362125-30-01		
		CHECKED :	TH. MIZUGUCHI	2018. 09. 06	PART NO.		GT32-4DP-1.5V (C) (30)		
		DESIGNED :	TS. KUBOTA	2018. 09. 05	CODE NO.		CL0782-0067-0-30		
		DRAWN :	TS. KUBOTA	2018. 09. 05					