

Sep.1.2024 Copyright 2024 HIROSE ELECTRIC CO., LTD. All Rights Reserved.  
In case of consideration for using Automotive equipment / device which demand high reliability, kindly contact our sales window correspondents.

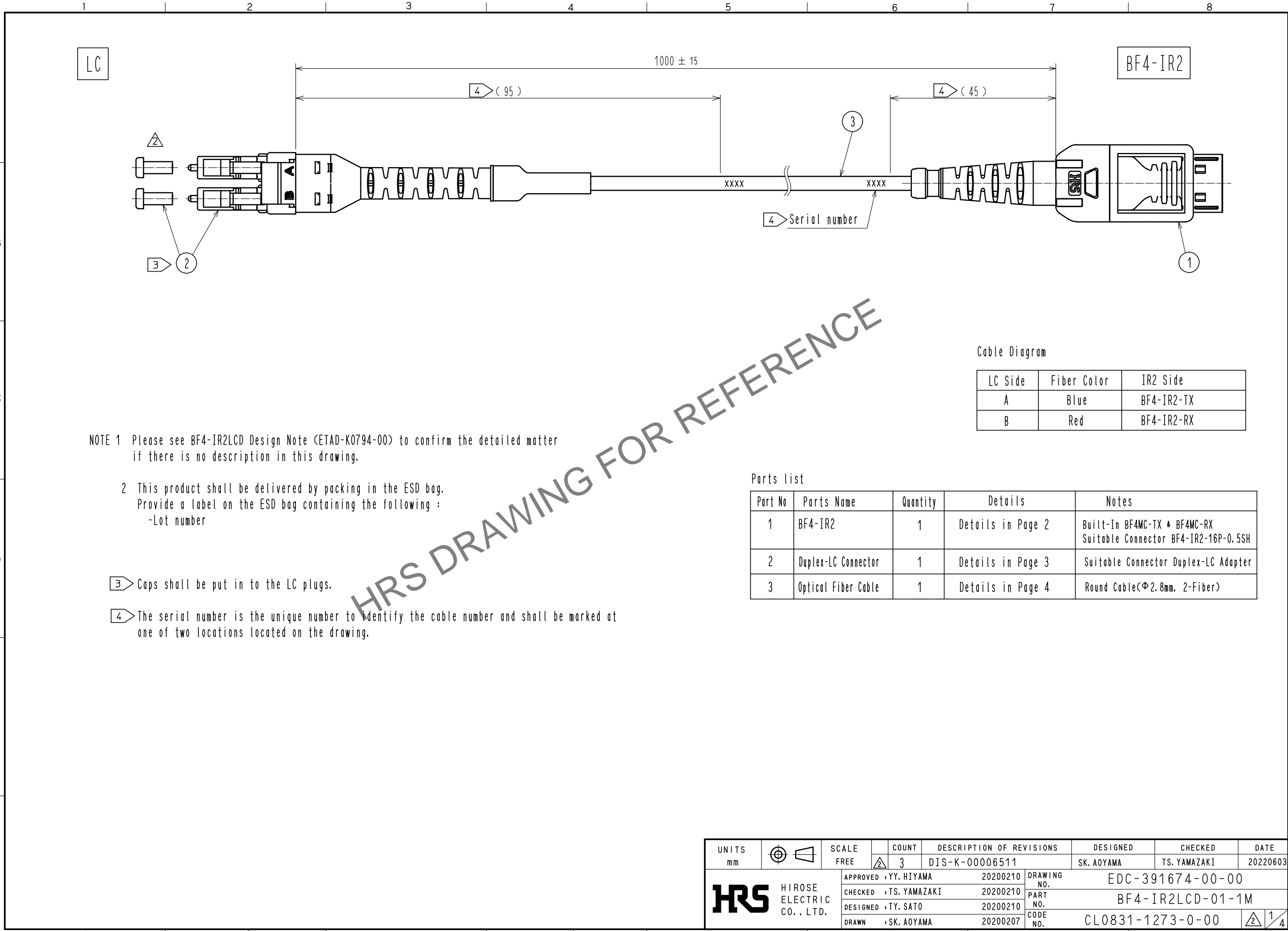

NOTE 1 Please see BF4-IR2LCD Design Note (ETAD-K0794-00) to confirm the detailed matter if there is no description in this drawing.

2 This product shall be delivered by packing in the ESD bag.  
Provide a label on the ESD bag containing the following :  
-Lot number

③ Caps shall be put in to the LC plugs.

④ The serial number is the unique number to identify the cable number and shall be marked at one of two locations located on the drawing.

Cable Diagram

LC Side	Fiber Color	IR2 Side
A	Blue	BF4-IR2-TX
B	Red	BF4-IR2-RX

Parts list

Part No	Parts Name	Quantity	Details	Notes
1	BF4-IR2	1	Details in Page 2	Built-In BF4MC-TX • BF4MC-RX Suitable Connector BF4-IR2-16P-0.5SH
2	Duplex-LC Connector	1	Details in Page 3	Suitable Connector Duplex-LC Adapter
3	Optical Fiber Cable	1	Details in Page 4	Round Cable(Φ2.8mm, 2-Fiber)

UNITS mm	SCALE FREE	COUNT 3	DESCRIPTION OF REVISIONS DIS-K-00006511	DESIGNED	CHECKED	DATE
				SK. AOYAMA	TS. YAMAZAKI	20220603
HIROSE ELECTRIC CO., LTD.	APPROVED : YY. HIYAMA	20200210	DRAWING NO. EDC-391674-00-00			
	CHECKED : TS. YAMAZAKI	20200210				
	DESIGNED : TY. SATO	20200210				
	DRAWN : SK. AOYAMA	20200207				
			PART NO. BF4-IR2LCD-01-1M			
			CODE NO. CL0831-1273-0-00			
			② 1/4			

Sep.1.2024 Copyright 2024 HIROSE ELECTRIC CO., LTD. All Rights Reserved.  
 In case of consideration for using Automotive equipment / device which demand high reliability, kindly contact our sales window correspondents.

Details of BF4-IR2

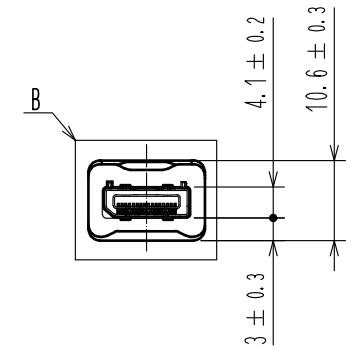
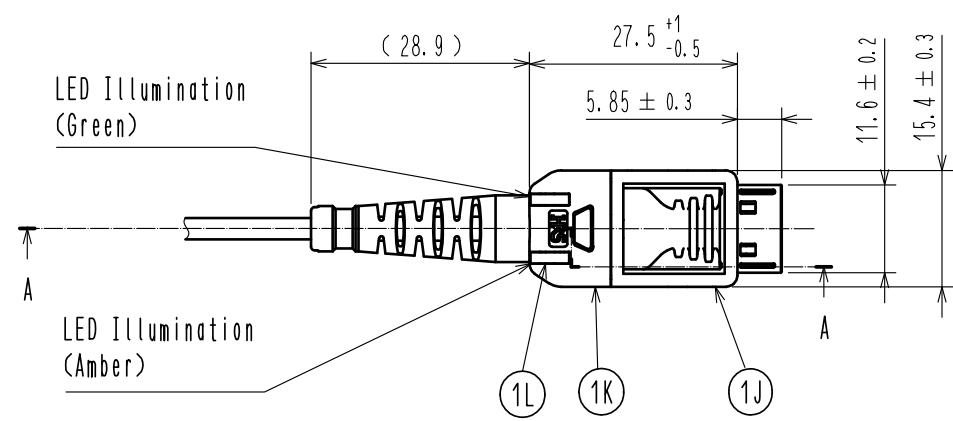

Pin Number

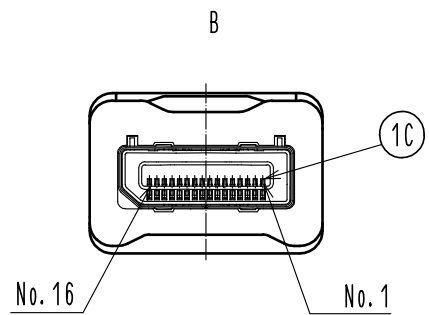

Mated Condition

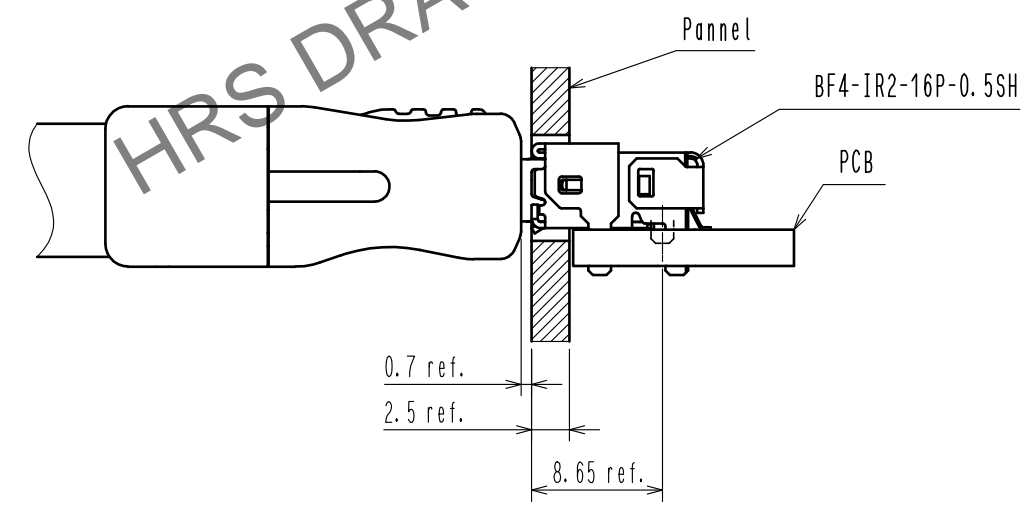

A-A

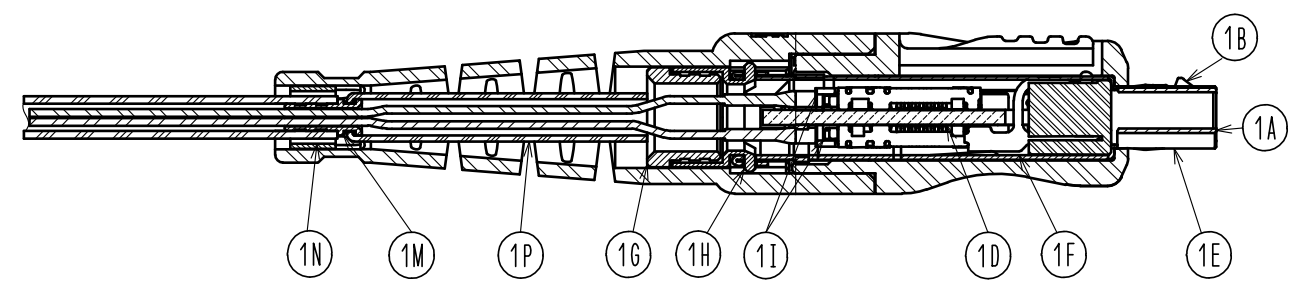

Parts List

Part No	Parts Name	Qty/IR2	Material
1A	S Housing	1	PA (Black)
1B	S Lock Spring	2	Stainless Steel (Au Plating)
1C	S Contact	16	Copper Alloy (Au Plating)
1D	PCBA	1	Including BF4 Receptacles
1E	Shield Shell A	1	Stainless Steel (Ni Plating)
1F	Shield Shell B	1	Stainless Steel (Ni Plating)
1G	Ring	1	Brass (Ni Plating)
1H	Fixed Ring	1	Aluminium
1I	BF4 Plug	2	—
1J	S Cover Case A	1	PBT (Black)
1K	S Cover Case B	1	Polyester Elastomer (Blue)
1L	Light Guiding Pipe	2	PC (Transparent)
1M	Cable Clamper	1	Brass (Ni Plating)
1N	Clamping Ring	1	Brass (Ni Plating)
1P	Heat Shrink Tubing	1	Polyolefin (Black)

Pin Layout

No	Pin Name	I/O	No	Pin Name	I/O
1	VDD	Power	9	GND	GND
2	VDD	Power	10	EO-DATA-	Input
3	GEN-LEDn	Input	11	EO-DATA+	Input
4	OE-SDn	Output	12	GND	GND
5	ANDATA	Output	13	EO-ACT	Input
6	GND	GND	14	EO-ACTn	Output
7	OE-DATA-	Output	15	AMB-LEDn	Input
8	OE-DATA+	Output	16	N. C.	N. C.

<b>HRS</b>	DRAWING NO.	EDC-391674-00-00
	PART NO.	BF4-IR2LCD-01-1M
	CODE NO.	CL0831-1273-0-00

Sep.1.2024 Copyright 2024 HIROSE ELECTRIC CO., LTD. All Rights Reserved.  
 In case of consideration for using Automotive equipment / device which demand high reliability, kindly contact our sales window correspondents.

Details of Duplex-LC Connector

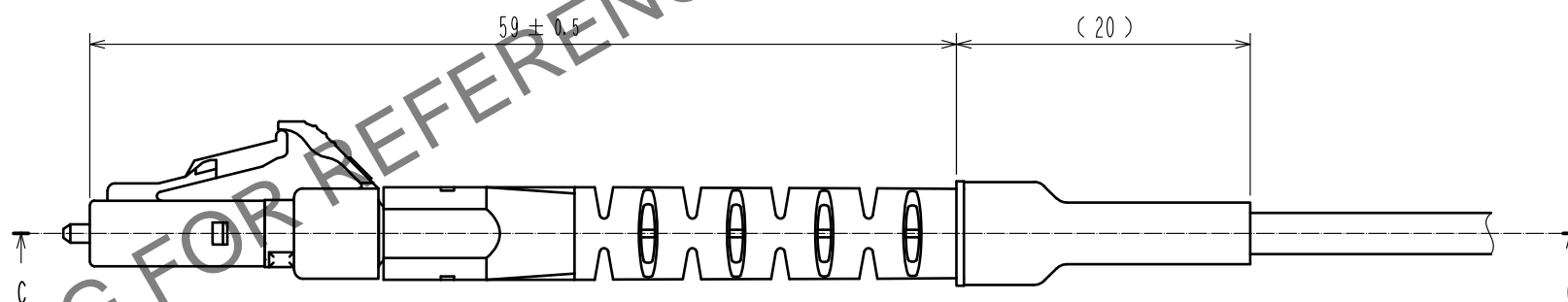
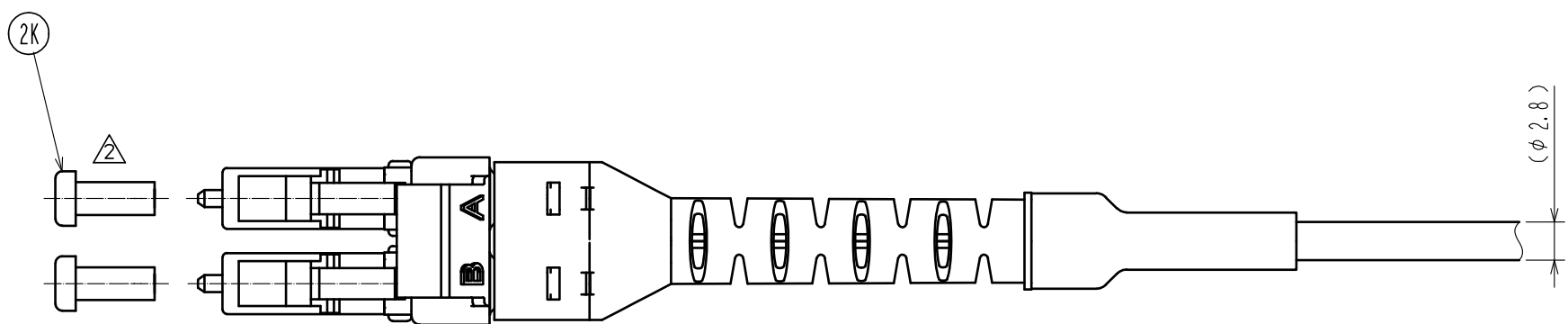
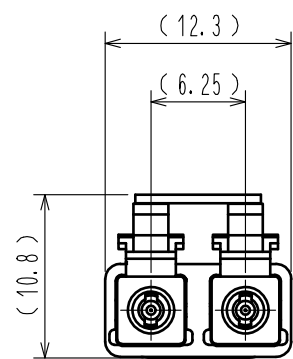

Parts List

Part No	Parts Name	Quantity	Material
2A	Plug Housing	2	PEI (Beige)
2B	Extender Cap	2	PEI (Beige) + Al Alloy
2C	LC Ferrule	2	ZrO2 + Brass (Ni Plating)
2D	Spring	2	SUS304
2E	Side Clip	1	PP (Beige)
2F	Boot	1	Polyester Elastomer (Blue)
2G	Boot Holder	1	Brass (Ni Plating)
2H	Cable Clamper	1	Brass (Ni Plating)
2I	Clamp Ring	1	Brass (Ni Plating)
2J	Heat Shrink Tubing	1	Polyolefin (Black)
2K	Cap	2	TPEE (Black)

HRS DRAWING FOR REFERENCE

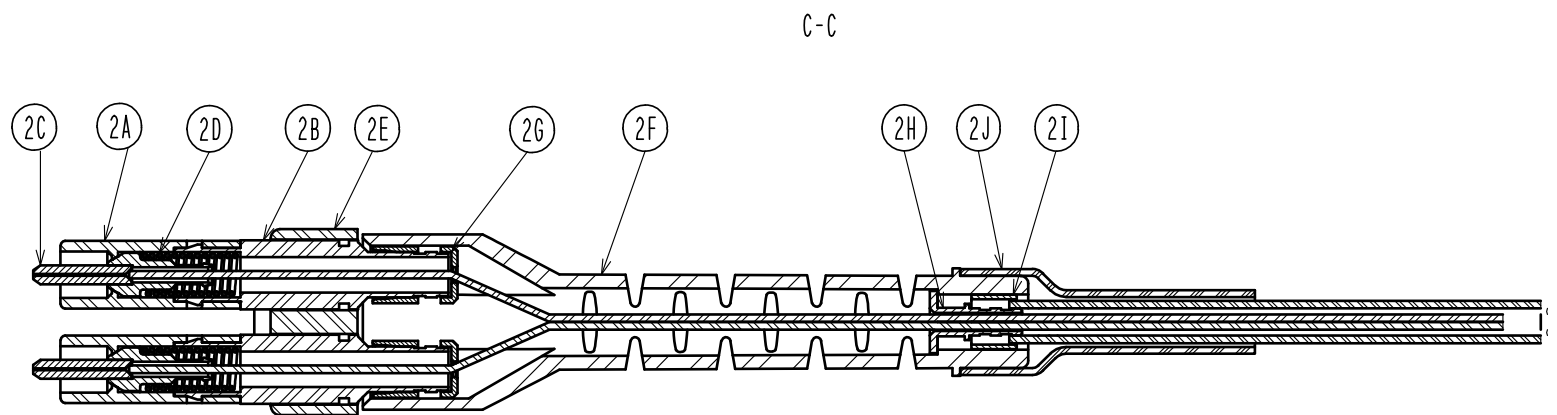

<b>HRS</b>	DRAWING NO.	EDC-391674-00-00
	PART NO.	BF4-IR2LCD-01-1M
	CODE NO.	CL0831-1273-0-00
		3/4

Sep.1.2024 Copyright 2024 HIROSE ELECTRIC CO., LTD. All Rights Reserved.  
 In case of consideration for using Automotive equipment / device which demand high reliability, kindly contact our sales window correspondents.

# Details of 2-Fiber Round Cable

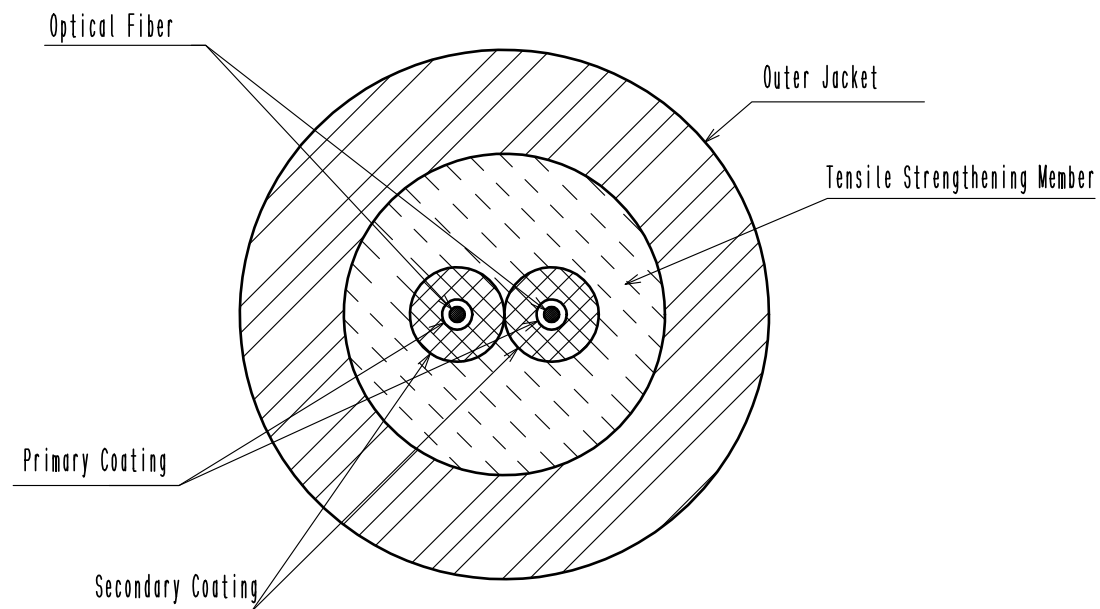

### Optical Fiber

Fiber Type	GI(50/80)
Material	Silica Glass
N. A.	0.275±0.015
Core Diameter	50±5µm
Cladding Diameter	80±1µm
Eccentricity (Core/Cladding)	<3µm
Core Circularity	<6%
Cladding Circularity	<2%

### Primary Coating

Material	UV Cureable Resin
Outer Diameter	165±10µm
Color	Blue / Red

### Secondary Coating

Material	Fluororesin
Outer Diameter	0.5±0.1mm
Color	Clear

### Tensile Strengthening Member

Material	Aramid Fiber (Kevlar)
Color	Yellow

### Outer Jacket

Material	PVC
Outer Jacket Diameter	2.8±0.2mm
Color	Orange

6 Reference Data --- Failure Rate of the Fiber During Static Bending

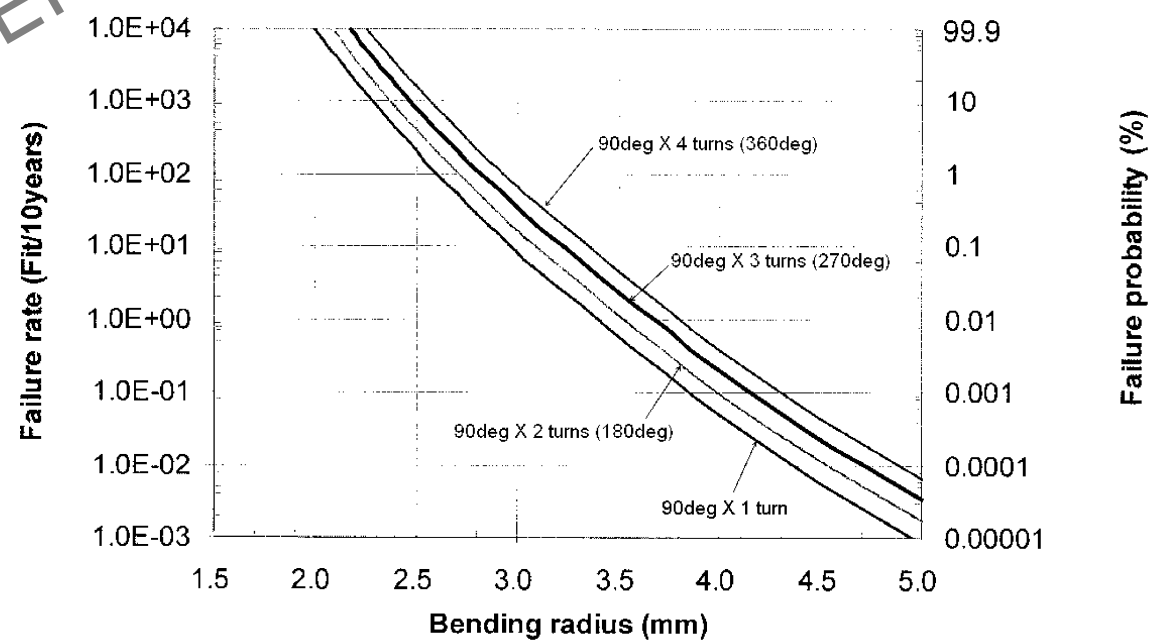

Note 5 The optical fiber coating contains dibutyltin compounds (DBT) less than 1000ppm as an intentionally-doped catalyser. REACH regurations restricts 1000ppm exceeding DBT.

Note 6 The data is only for technical reference. The data shows the failure rate during static bending of the tight-buffered fiber that does not include outer jacket and strenghening member.

<b>HRS</b>	DRAWING NO.	EDC-391674-00-00
	PART NO.	BF4-IR2LCD-01-1M
	CODE NO.	CL0831-1273-0-00
		4/4