

# GT16G Series

— 6 GHz Compatible Antenna Connector —

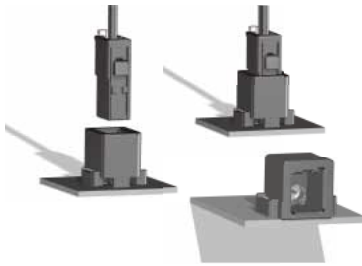
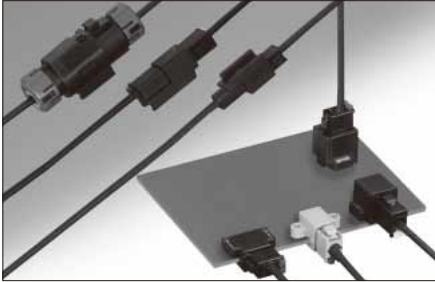

## ■ Features

- **Excellent high frequency performance**  
V.S.W.R. is 1.5 or less (DC to 6 GHz)
- **Satisfies rigorous test conditions for automotive devices.**
- **Robust lock design provides a tactile click.**  
-Lock strength : 98N Min.
- **Many variations**
  - Board connectors :  
SMT type, mid-mount type, lead reflow type
  - In-line connectors :  
Retainer-less type, double latching type, bracket type, waterproof type
- **RoHS compliant**
- ◆ **Applications**  
Automotive WiFi/Bluetooth, V2X, DSRC, etc.

## ■ High Frequency Performance

- **Excellent high frequency performance with a V.S.W.R. of 1.5 or less in all frequencies between DC and 6 GHz.**
- **Proven track record as connector for automotive ETC and automotive WiFi/Bluetooth.**

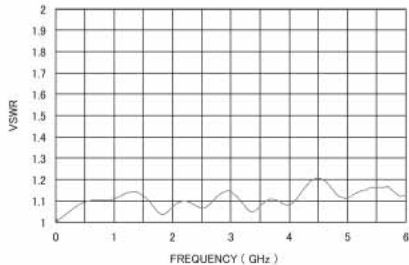

\*Data taken based on GT16GH-1P-DSA and GT16G-1SHU(24).

## ■ Product Specifications

Ratings	Rated current : 1A		Rated voltage : 250V AC	
	Operating temperature range : -30°C to 105°C		Storage temperature range : -40°C to 105°C	
Item	Specifications		Conditions	
1. Insulation Resistance	100MΩ min		Measured at 500V DC	
2. Withstanding Voltage	There shall be no flashover or dielectric breakdown.		650V AC applied for 1 minute.	
3. Contact resistance	Center contact : 30mΩ max, Outer contact : 60mΩ max		Measured at 1A DC	
4. High Frequency Characteristics	V.S.W.R. is 1.5 or less		Measured in a range between 0 and 6 GHz, Characteristic impedance: 50Ω	
5. Heat resistance	Center contact : 60mΩ max, Outer contact : 120mΩ max		105°C for 300 hours	
6. Low temperature resistance	Center contact : 60mΩ max, Outer contact : 120mΩ max		-40°C, 120 hours	
7. Vibration resistance	There shall be no electrical discontinuity of 10 μs or more.		Frequency : 20-200Hz, Acceleration : 43.1m/s <sup>2</sup> in 3 directions for 3 hours.	
8. Humidity resistance	Insulation resistance : 100MΩ min		Left unattended at a temperature of 60°C, and humidity of 90 to 95% for 96 hours.	
9. Temperature cycles	Center contact : 60mΩ max, Outer contact : 120mΩ max. There shall be no damage, cracks or loosened parts.		Temperature -40°C → Room temperature → 105°C → Room temperature Time : 30 min → 5 min → 30 min → 5 min, 1000 cycles	
10. Mating durability	Center contact : 60mΩ max, Outer contact : 120mΩ max		30 mating cycles (insertion/extraction)	
11. Solder heat resistance	There shall be no deformation or excessive play of contacts or other parts.		-Reflow : Perform twice at the specified temperature profile. -Soldering iron : 350°C, 10 sec max.	

## Product Number Structure

Refer to the chart below to determine product specifications from the product number.

### Board Connector/In-line Connector

**GT 16G \* - 1 P - H**

①      ②      ③      ④      ⑤      ⑥

① Series name : GT	⑤ Contact type Board connector P : Pin header In-line connector S : Socket P : In-line plug PP : In-line plug with bracket P/S : Available for both male and female
② Series No : 16C, 16G, 5W	
③ Series Sub No : Serial No.	
④ Pin-count : 1	
⑥ Product type Board connector H : Right angle DSA : Straight In-line connector HU : Housing R : Retainer	

### Center Contact/Outer Contact

**GT 16G \* - 2428 SCF**

①      ②      ③      ④      ⑤

① Series name : GT	⑤ Type category/Packaging type Center SCF : Socket crimp contact/reel PCF : Plug crimp contact/reel Outer shell SC : Socket crimp contact/piece PC : Plug crimp contact/piece
② Series No : 16G	
③ Series Sub No : Serial No..	
④ licable wire Center 2428 : AWG# 24 to 28 Outer/1.6-2.9 : 1.5D-2W or equivalent	

### Insulator/Contact Ferrule/Outer Ferrule

**GT 16G - SC**

①      ②      ③

① Series name : GT	③ Part name SC : Female insulator PC : Male insulator FR : Contact ferrule 1.5 DHQS : Outer Ferrule
② Series No : 16G	

## GT16G Series Mating Table

F Connector	M Connector	
GT16GM-1S-ASSY (Retainer-less type)	SMT type	GT16GMP-1P-H(55)
	Board mid-mount type	GT16GM-1P-H(55)
	In-line type	GT16GM-1P-ASSY
	In-line bracket type	GT16GMN-1PP-ASSY
GT16G-1S-ASSY GT16GT-1S-ASSY (Double latch type)	SMT type	GT16GD-1P-H(55)
		GT16GT-1P-H(55)
		GT16GH-1P-H
	Board mid-mount type	GT16G-1P-H(55)
		GT16GL-1P-H(55)D
		GT16GRL-1P-H(55)
Lead reflow type	GT16GH-1P-DSA	
In-line bracket type	GT16GT-1PP-ASSY	
GT16GW-1S-ASSY	Waterproof in-line type	GT16GW-1P-ASSY

## Harness Connector

### ●GT16GM-1S-ASSY

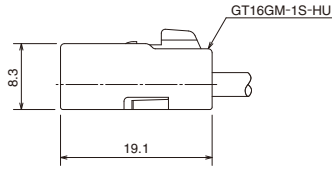

\*Uses two insulators per termination.

## Housing/Insulator

Part	Housing	Insulator
Part No.	GT16GM-1S-HU	GT16G-SC
HRS No.	766-0033-9	766-0023-5
Material	PBT	PBT
Color	Black	Natural
Sales unit	1	1
RoHS	○	○
Dimensions		

## Center Contact/Outer Contact

Part	Center Contact	Outer Contact
Part No.	GT16G-2428SCF	GT16GM-/1.6-2.9SC
HRS No.	766-0022-2	766-0025-0
Material	Phosphor bronze	Phosphor bronze
Finish	Tin plating	Tin plating
Applicable wire	AWG#24~28	1.5D-2W or equivalent
Sales unit	10,000 pcs/reel	1
RoHS	○	○
Dimensions		

## Contact Ferrule/Outer Ferrule

Part	Contact Ferrule	Outer Ferrule
Part No.	GT16G-FR	GT16G-1.5DHQS
HRS No.	766-0028-9	766-0027-6
Material	Phosphor bronze	Phosphor bronze
Finish	Tin plating	Tin plating
Sales unit	1	1
RoHS	○	○
Dimensions		

## ●GT16GM-1P-ASSY



## ●GT16GMN-1PP-ASSY

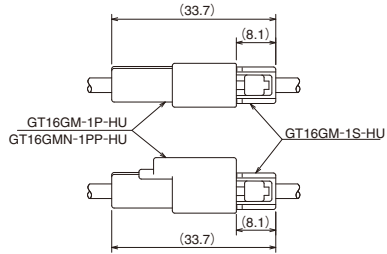

\*Uses two insulators per termination.

## ■Housing/Insulator

Part	Housing		Insulator
Part No.	GT16GM-1P-HU	GT16GMN-1PP-HU	GT16G-PC
HRS No.	766-0050-8	766-0051-0	766-0047-3
Material	PBT	PBT	PBT
Color	Black	Black	Natural
Sales unit	1	1	1
RoHS	○	○	○
Dimensions			

## ■Center Contact/Outer Contact

Part	Center Contact	Outer Contact
Part No.	GT16G-2428PCF	GT16G-/1.6-2.9PC
HRS No.	766-0046-0	766-0048-6
Material	Brass	Phosphor bronze
Finish	Tin plating	Tin plating
Applicable wire	AWG#24~28	1.5D-2W or equivalent
Sales unit	10,000 pcs/reel	1
RoHS	○	○
Dimensions		

## ■Contact Ferrule/Outer Ferrule

Part	Contact Ferrule	Outer Ferrule
Part No.	GT16G-FR	GT16G-1.5DHQS
HRS No.	766-0028-9	766-0027-6
Material	Phosphor bronze	Phosphor bronze
Finish	Tin plating	Tin plating
Sales unit	1	1
RoHS	○	○
Dimensions		

●GT16G-1S-ASSY

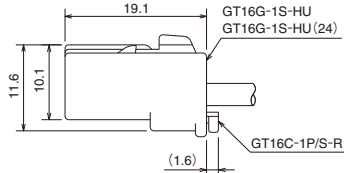

\*Uses two insulators per termination.

■Housing/Insulator/Retainer

Part	Housing		Insulator	Retainer
Part No.	GT16G-1S-HU	GT16G-1S-HU(24)	GT16G-SC	GT16C-1P/S-R
HRS No.	766-0026-3	766-0026-3-24	766-0023-5	766-0011-6
Material	PBT	PBT	PBT	PBT
Color	Light gray	Black	Natural	Dark gray
Sales unit	1	1	1	1
RoHS	○	○	○	○
Dimensions				

■Center Contact/Outer Contact

Part	Center Contact	Outer Contact
Part No.	GT16G-2428SCF	GT16G-/1.6-2.9SC
HRS No.	766-0022-2	766-0024-8
Material	Phosphor bronze	Phosphor bronze
Finish	Tin plating	Tin plating
Applicable wire	AWG#24~28	1.5D-2W or equivalent
Sales unit	10,000 pcs/reel	1
RoHS	○	○
Dimensions		

■Contact Ferrule/Outer Ferrule

Part	Contact Ferrule	Outer Ferrule
Part No.	GT16G-FR	GT16G-1.5DHQS
HRS No.	766-0028-9	766-0027-6
Material	Phosphor bronze	Phosphor bronze
Finish	Tin plating	Tin plating
Sales unit	1	1
RoHS	○	○
Dimensions		

Apr. 1, 2022 Copyright 2022 HIROSE ELECTRIC CO., LTD. All Rights Reserved.

GT5 GT13 GT16 GT19 FH65 FH40 FH35 FH67

GT5  
GT13  
GT16  
GT19  
GT21  
GT36  
GT43  
GT17  
GT32  
GT25  
KM32  
ZE05  
ZG052  
HM-200  
ZG04W  
T2023  
FX26  
DF40  
DF40GL  
RH28K  
FH2K  
FH65  
FH40  
FH63  
FH67

●GT16GT-1S-ASSY

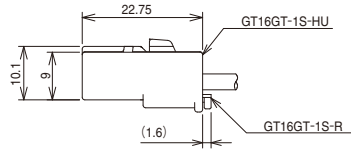

\*Uses two insulators per termination.

■Housing/Insulator/Retainer

Part	Housing	Insulator	Retainer
Part No.	GT16GT-1S-HU	GT16G-SC	GT16GT-1S-R
HRS No.	766-0098-4	766-0023-5	766-0099-7
Material	PBT	PBT	PBT
Color	Black	Natural	Natural
Sales unit	1	1	1
RoHS	○	○	○
Dimensions			

■Center Contact/Outer Contact

Part	Center Contact	Outer Contact
Part No.	GT16G-2428SCF	GT16G-/1.6-2.9SC
HRS No.	766-0022-2	766-0024-8
Material	Phosphor bronze	Phosphor bronze
Finish	Tin plating	Tin plating
Applicable wire	AWG#24~28	1.5D-2W or equivalent
Sales unit	10,000 pcs/reel	1
RoHS	○	○
Dimensions		

■Contact Ferrule/Outer Ferrule

Part	Contact Ferrule	Outer Ferrule
Part No.	GT16G-FR	GT16G-1.5DHQS
HRS No.	766-0028-9	766-0027-6
Material	Phosphor bronze	Phosphor bronze
Finish	Tin plating	Tin plating
Sales unit	1	1
RoHS	○	○
Dimensions		

Apr. 1. 2022 Copyright 2022 HIROSE ELECTRIC CO., LTD. All Rights Reserved.

●GT16GT-1PP-ASSY

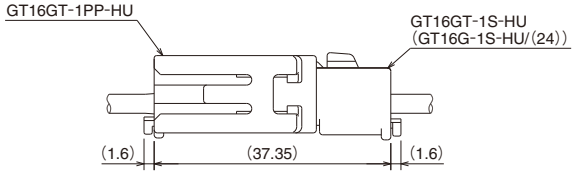

\*Uses two insulators per termination.

■Housing/Insulator/Retainer

Part	Housing	Insulator	Retainer
Part No.	GT16GT-1PP-HU	GT16G-PC	GT16C-1P/S-R
HRS No.	766-0049-9	766-0047-3	766-0011-6
Material	PBT	PBT	PBT
Color	Black	Natural	Dark gray
Sales unit	1	1	1
RoHS	○	○	○
Dimensions			

■Center Contact/Outer Contact

Part	Center Contact	Outer Contact
Part No.	GT16G-2428PCF	GT16G-/1.6-2.9PC
HRS No.	766-0046-0	766-0048-6
Material	Brass	Phosphor bronze
Finish	Tin plating	Tin plating
Applicable wire	AWG#24~28	1.5D-2W or equivalent
Sales unit	10,000 pcs/reel	1
RoHS	○	○
Dimensions		

■Contact Ferrule/Outer Ferrule

Part	Contact Ferrule	Outer Ferrule
Part No.	GT16G-FR	GT16G-1.5DHQS
HRS No.	766-0028-9	766-0027-6
Material	Phosphor bronze	Phosphor bronze
Finish	Tin plating	Tin plating
Sales unit	1	1
RoHS	○	○
Dimensions		

●GT16GW-1P-ASSY

●GT16GW-1S-ASSY

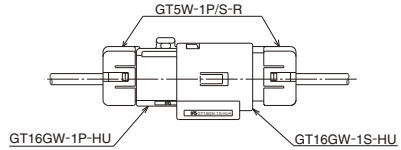

\*Uses two insulators per termination.

■Housing/Insulator/Retainer

Part	Housing		Insulator		Retainer
Part No.	GT16GW-1P-HU	GT16GW-1S-HU	GT16G-PC	GT16G-SC	GT5W-1P/S-R
HRS No.	766-0077-4	766-0076-1	766-0047-3	766-0023-5	755-0028-5
Material	PBT	PBT/ Silicon rubber	PBT	PBT	PBT/ Silicon rubber
Color	Black	Black/White	Natural	Natural	Dark gray/ Right blue
Sales unit	1	1	1	1	1
RoHS	○	○	○	○	○
Dimensions					

■Center Contact/Outer Contact

Part	Center Contact		Outer Contact	
Part No.	GT16G-2428PCF	GT16G-2428SCF	GT16G-/1.6-2.9PC	GT16G-/1.6-2.9SC
HRS No.	766-0046-0	766-0022-2	766-0048-6	766-0024-8
Material	Brass	Phosphor bronze	Phosphor bronze	Phosphor bronze
Finish	Tin plating	Tin plating	Tin plating	Tin plating
Applicable wire	AWG#24~28	AWG#24~28	1.5D-2W or equivalent	1.5D-2W or equivalent
Sales unit	10,000 pcs/reel	10,000 pcs/reel	1	1
RoHS	○	○	○	○
Dimensions				

■Contact Ferrule/Outer Ferrule

Part	Contact Ferrule	Outer Ferrule
Part No.	GT16G-FR	GT16G-1.5DHQS
HRS No.	766-0028-9	766-0027-6
Material	Phosphor bronze	Phosphor bronze
Finish	Tin plating	Tin plating
Sales unit	1	1
RoHS	○	○
Dimensions		



**Board connector**

- SMT type (On Board)
- ◆ GT16GMP-1P-H (55)



**Dimensions**

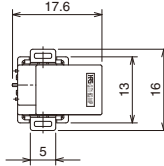

**Recommended Panel Dimensions**

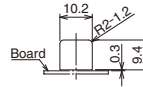

**Recommended Board Dimensions**

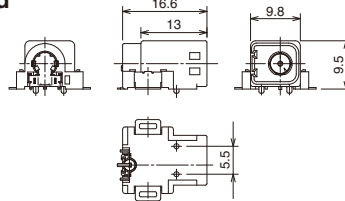
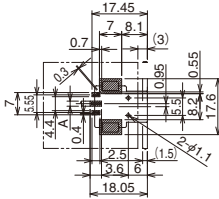

**Mated Connector**

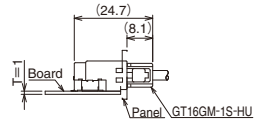

Note : Adjust dimension A of the microstrip line to satisfy 50Ω characteristic impedance.

Part No.	HRS No.	Part	Material	Finish or color	Sales unit	RoHS
GT16GMP-1P-H(55)	766-0052-3 55	Housing	PPS	Black	200 pcs/reel	○
		Center Terminal	Phosphor bronze	Tin plating		
		Outer terminal	Phosphor bronze	Tin plating		
		Insulators L, R	PPS	Natural		
		Shield plate	Phosphor bronze	Tin plating		
		Retention tab	Brass	Tin plating		

◆ GT16GD-1P-H (55)



**Dimensions**

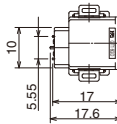

**Recommended Panel Dimensions**

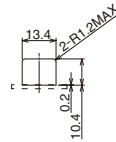

**Recommended Board Dimensions**

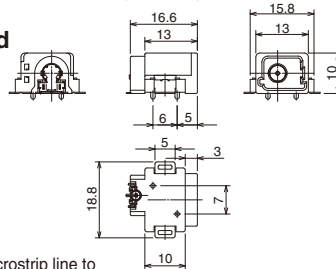
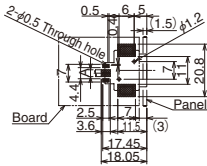

**Mated Connector**

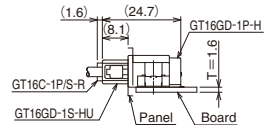

Note : Adjust dimension A of the microstrip line to satisfy 50Ω characteristic impedance.

Part No.	HRS No.	Part	Material	Finish or color	Sales unit	RoHS
GT16GD-1P-H(55)	766-0044-5 55	Housing	PPS	Black	200 pcs/reel	○
		Center Terminal	Phosphor bronze	Tin plating		
		Outer terminal	Phosphor bronze	Tin plating		
		Insulators L, R	PPS	Natural		
		Shield plate	Phosphor bronze	Tin plating		
		Retention tab	Brass	Tin plating		

◆GT16GT-1P-H (55)



◆Dimensions

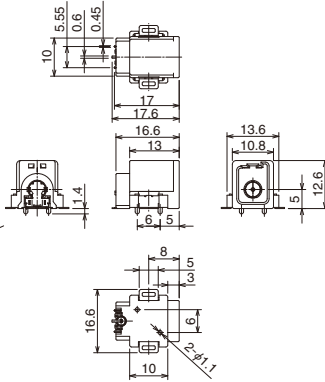

◆Recommended Panel Dimensions

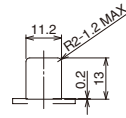

◆Recommended Board Dimensions

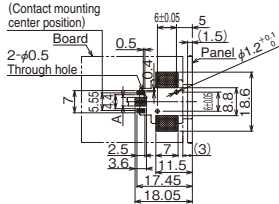

◆Mated Connector

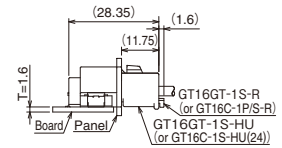

Note : Adjust dimension A of the microstrip line to satisfy 50Ω characteristic impedance.

Part No.	HRS No.	Part	Material	Finish or color	Sales unit	RoHS
GT16GT-1P-H(55)	766-0104-5 55	Housing	PPS	Black	200 pcs/reel	○
		Center Terminal	Phosphor bronze	Tin plating		
		Outer terminal	Phosphor bronze	Tin plating		
		Insulators L, R	PPS	Natural		
		Shield plate	Phosphor bronze	Tin plating		
		Retention tab	Brass	Tin plating		

◆GT16GH-1P-H (Fixing Pin: Lead Reflow type)



◆Dimensions

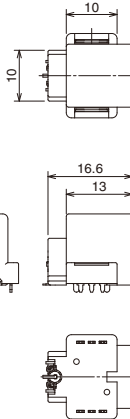

◆Recommended Panel Dimensions

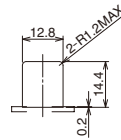

◆Recommended Board Dimensions

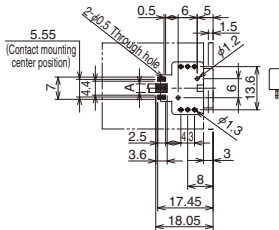

◆Mated Connector

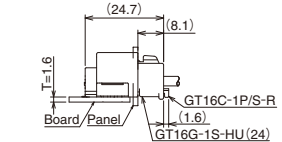

Note : Adjust dimension A of the microstrip line to satisfy 50Ω characteristic impedance.

Part No.	HRS No.	Part	Material	Finish or color	Sales unit	RoHS
GT16GH-1P-H	766-0118-0	Housing	PPS	Black	200 pcs/reel	○
		Center Terminal	Phosphor bronze	Tin plating		
		Outer terminal	Phosphor bronze	Tin plating		
		Insulators L, R	PPS	Natural		
		Shield plate	Phosphor bronze	Tin plating		
		Retention tab	Brass	Tin plating		

GT5  
GT13  
GT16  
GT19  
GT21  
GT36  
GT43  
GT17  
GT32  
GT25  
KM37  
ZE05  
ZE01/2  
HM-200  
ZE04W  
I2032K  
EX26  
DF40  
DF40GL  
RH28K  
FH2K  
FH65  
FH40  
FH63  
FH67



GT5  
 GT13  
**GT16**  
 GT19  
 GT21  
 GT36  
 GT43  
 GT17  
 GT32  
 GT25  
 KM37  
 ZE05  
 ZG052  
 HH-W-200  
 ZG044  
 T23232  
 FX26  
 DF40  
 DF40GL  
 FH28K  
 FH2K  
 FH65  
 FH40  
 FH63  
 FH67

Apr. 1. 2022 Copyright 2022 HIROSE ELECTRIC CO., LTD. All Rights Reserved.

◆GT16GL-1P-H(55)D (Fixing Pin: Lead Reflow type)



◆Dimensions

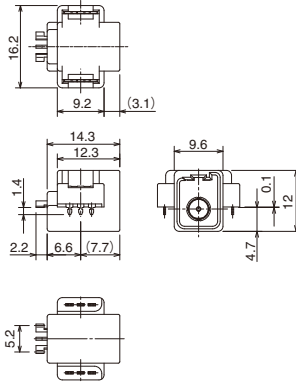

◆Recommended Panel Dimensions

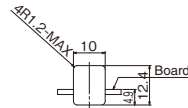

◆Recommended Board Dimensions

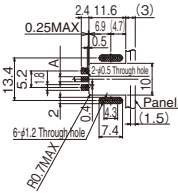

◆Mated Connector

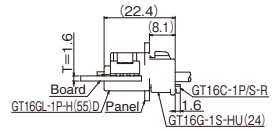

Note : Adjust dimension A of the microstrip line to satisfy 50Ω characteristic impedance.

Part No.	HRS No.	Part	Material	Finish or color	Sales unit	RoHS
GT16GL-1P-H(55)D	766-0103-2 55	Housing	PPS	Black	200 pcs/reel	○
		Center Terminal	Phosphor bronze	Tin plating		
		Outer terminal	Phosphor bronze	Tin plating		
		Insulators	PPS	Natural		
		Metal reinforcement	Brass	Tin plating		

◆GT16GRL-1P-H (55) (Fixing Pin: Lead Reflow type)



◆Dimensions

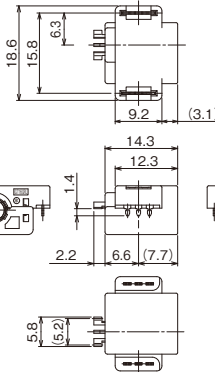

◆Recommended Panel Dimensions

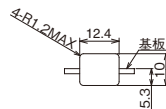

◆Recommended Board Dimensions

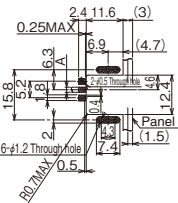

◆Mated Connector

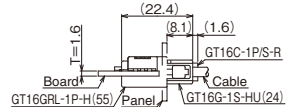

Note : Adjust dimension A of the microstrip line to satisfy 50Ω characteristic impedance.

Part No.	HRS No.	Part	Material	Finish or color	Sales unit	RoHS
GT16GRL-1P-H(55)	766-0101-7 55	Housing	PPS	Black	200 pcs/reel	○
		Center Terminal	Phosphor bronze	Tin plating		
		Outer terminal	Phosphor bronze	Tin plating		
		Insulators	PPS	Natural		
		Metal reinforcement	Brass	Tin plating		

●Lead reflow type (onboard)

◆GT16GH-1P-DSA



◆External dimensions

◆Mated connector

◆Recommended Board Dimensions

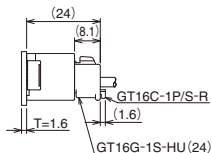
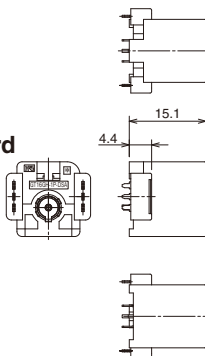
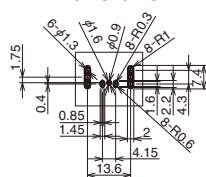

Part No.	HRS No.	Part	Material	Finish or color	Sales unit	RoHS
GT16GH-1P-DSA	766-0112-3	Housing	PPS	Black	1	○
		Center Terminal	Phosphor bronze	Tin plating		
		Outer terminal	Phosphor bronze	Tin plating		
		Insulators	PPS	Natural		
		Retention tab	Brass	Tin plating		

●GT16G Series Conversion Adapter

◆SMA Conversion Adapter



◆Dimensions

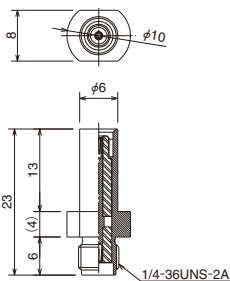

◆Dimensions

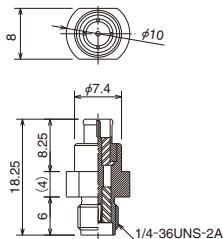

Part No.	HRS No.	Sales unit	RoHS
GT16GS-HRMJ	766-0031-3	1	○
GT16GP-HRMJ	766-0030-0	1	○

Note : The adapter does not have a lock so it can only be used for performance measurements.

## ◆ Precautions for use

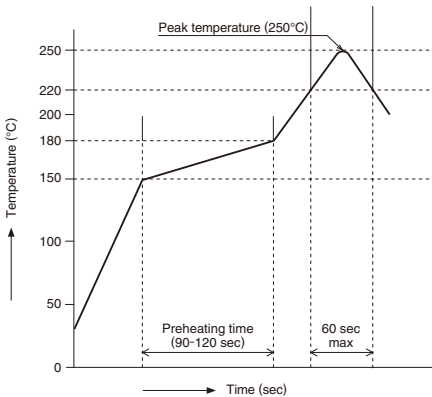
<p>1. Recommended temperature profile</p>	 <p>[Conditions]</p> <ol style="list-style-type: none"> <li>1. Peak temperature : 250°C</li> <li>2. Heating unit : 220°C min, 60 sec max.</li> <li>3. Preheating unit : 150 to 180°C for 90 to 120 sec</li> <li>4. Number of cycles : 2 cycles max</li> </ol> <p>Note 1 : Temperatures show the surface temperature of the board near the connector lead part.          Note 2 : If nitrogen reflow is used, mount the product at an oxygen concentration of no less than 1,000 [ppm].          Please contact us if your concentration will be below 1,000 [ppm].</p>
<p>2. Recommended hand soldering conditions</p>	<p>Soldering iron temperature : 340 ± 10°C Soldering time : 3 sec max</p>
<p>3. Recommended screen thickness : Aperture ratio (pattern area ratio)</p>	<p>Thickness : 0.15mm aperture ratio : 100%</p>
<p>4. Cleaning</p>	<p>Cleaning is not recommended. If the product must be cleaned, make sure to evaluate the outcome of its cleaning before use. (Cleaning may alter its mating/un-mating characteristics or resistance to environmental elements.)</p>
<p>5. Precautions</p>	<ul style="list-style-type: none"> <li>■ Be careful not to mate or un-mate the product without mounting it on the board This may cause damage or deform the contacts.</li> <li>■ Make sure not to support the board only by the connector. Implement other means to hold the board in place.</li> <li>■ Be careful not to apply excessive prying forces when mating or un-mating as doing so may result in damage</li> <li>■ Do not apply flux when hand soldering as this will cause flux wicking on the connector.</li> </ul>

## ● Crimping Tools

Applicable Connector		GT16GM-1S-ASS GT16G-1S-ASSY GT16GT-1S-ASSY GT16GW-1S-ASSY	GT16GM-1P-ASSY GT16GMN-1PP-ASSY GT16GT-1PP-ASSY GT16GW-1P-ASSY
Process 1.	Cable termination	Schleuniger MP257, etc.	Schleuniger MP257, etc.
2.	Center contact crimping	Crimping machine unit 105C type +	Crimping machine unit 105C type +
3.	Cable forming	AP105-GT16G-2428S Shield forming tool GT16G-1.5DHQS/CF-MD	AP105-GT16G-2428P Shield forming tool GT16G-1.5DHQS/CF-MD
4.	Inserting the outer ferrule	Outer ferrule insertion tool GT16G-1.5DHQS/PR-MD	Outer ferrule insertion tool GT16G-1.5DHQS/PR-MD
5.	Inserting the contact ferrule	Contact ferrule insertion tool GT16G-FR/PR-MD	Contact ferrule insertion tool GT16G-FR/PR-MD
6.	Attaching the insulator	Manual work	Manual work
7.	Inserting the outer shell	Insulator pushing tool GT16G-SC/PR-MD	—
8.	Caulking the outer shell	Hand press HOS-7 +	Hand press HOS-7 +
9.	Mounting the housing (retainer)	Manual work	Manual work
10.	Inspection	Inspection of high frequency characteristics Inspection of continuity/withstanding voltage Visual inspection	Inspection of high frequency characteristics Inspection of continuity/withstanding voltage Visual inspection

Please refer to our cable termination procedure manual for performing terminations.