

Jun.1.2020 Copyright 2020 HIROSE ELECTRIC CO., LTD. All Rights Reserved.
 In case of consideration for using Automotive equipment / device which demand high reliability, kindly contact our sales window correspondents.

COUNT	DESCRIPTION OF REVISIONS	BY	CHKD	DATE	COUNT	DESCRIPTION OF REVISIONS	BY	CHKD	DATE
1	DIS-C-000491	D.M	Y.Y	07.2.16					

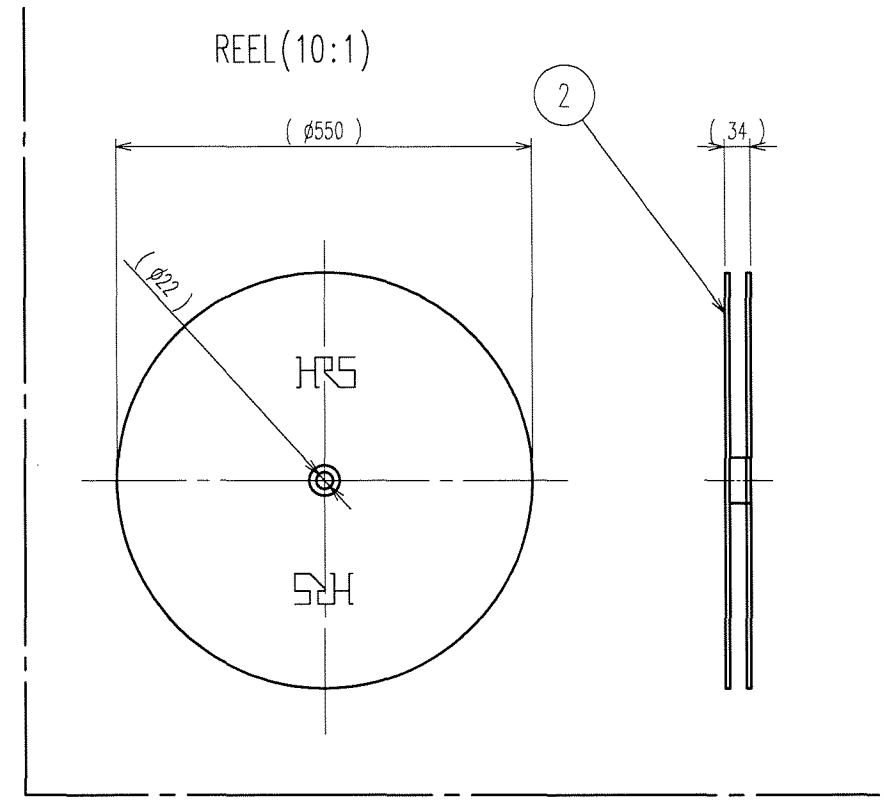
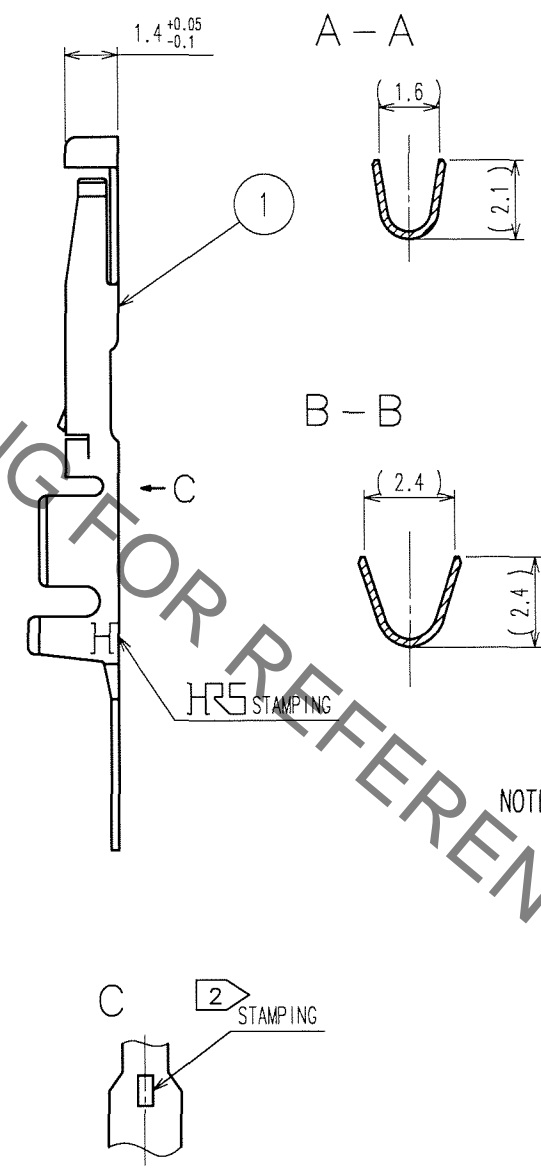
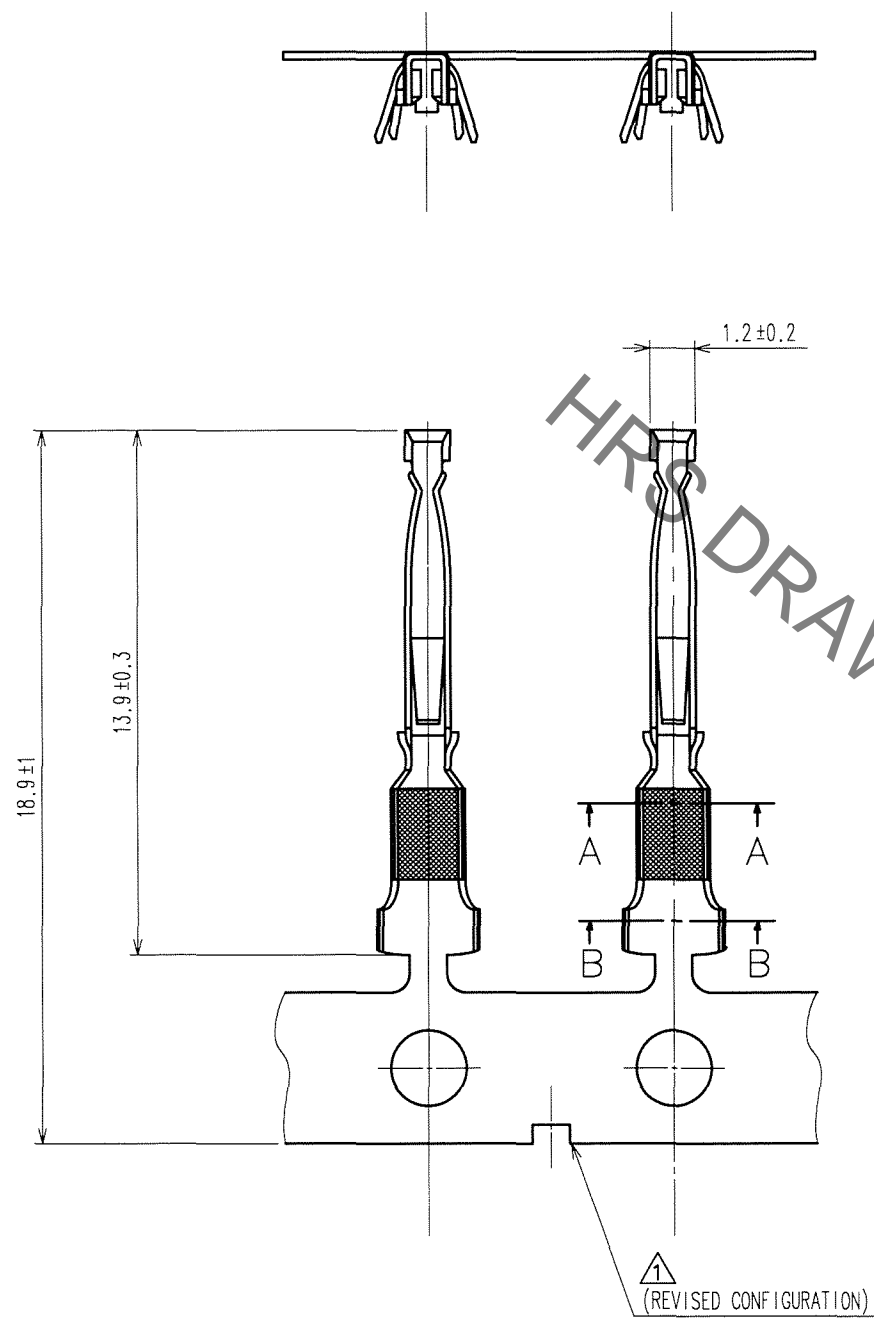

NOTE 1 APPLICABLE WIRE SIZE: AWG#22 TO 18
 2 STAMPING IS INDENTED ON RP13A-SC-212(AWG#22 TO 18)
 TO IDENTIFY FROM RP13A-SC-222(AWG#24 TO 28)

TO
R

1	PHOSPHOR BRONZE	SILVER PLATING(N=10000)	2	CARTON	(REEL)		
NO.	MATERIAL	FINISH, REMARKS	NO.	MATERIAL	FINISH, REMARKS		
CODE NO. (OLD)	CL		DRAWN	DESIGNED	CHECKED	APPROVED	RELEASED
			D.MATSUNE	D.MATSUNE	M.SATO	M.YOSHIDA	
			00.9.25	00.9.25	00.9.27	00.9.28	
SCALE	DRAWING NO.		PART NO.				
5 : 1	EDC3-009286		RP13A-SC-212				
UNITS	HRS HIROSE ELECTRIC CO., LTD		CODE NO.		CL113-0150-8		1/1
mm							