

Oct.1.2019 Copyright 2019 HIROSE ELECTRIC CO., LTD. All Rights Reserved.  
 In case of consideration for using Automotive equipment / device which demand high reliability, kindly contact our sales window correspondents.

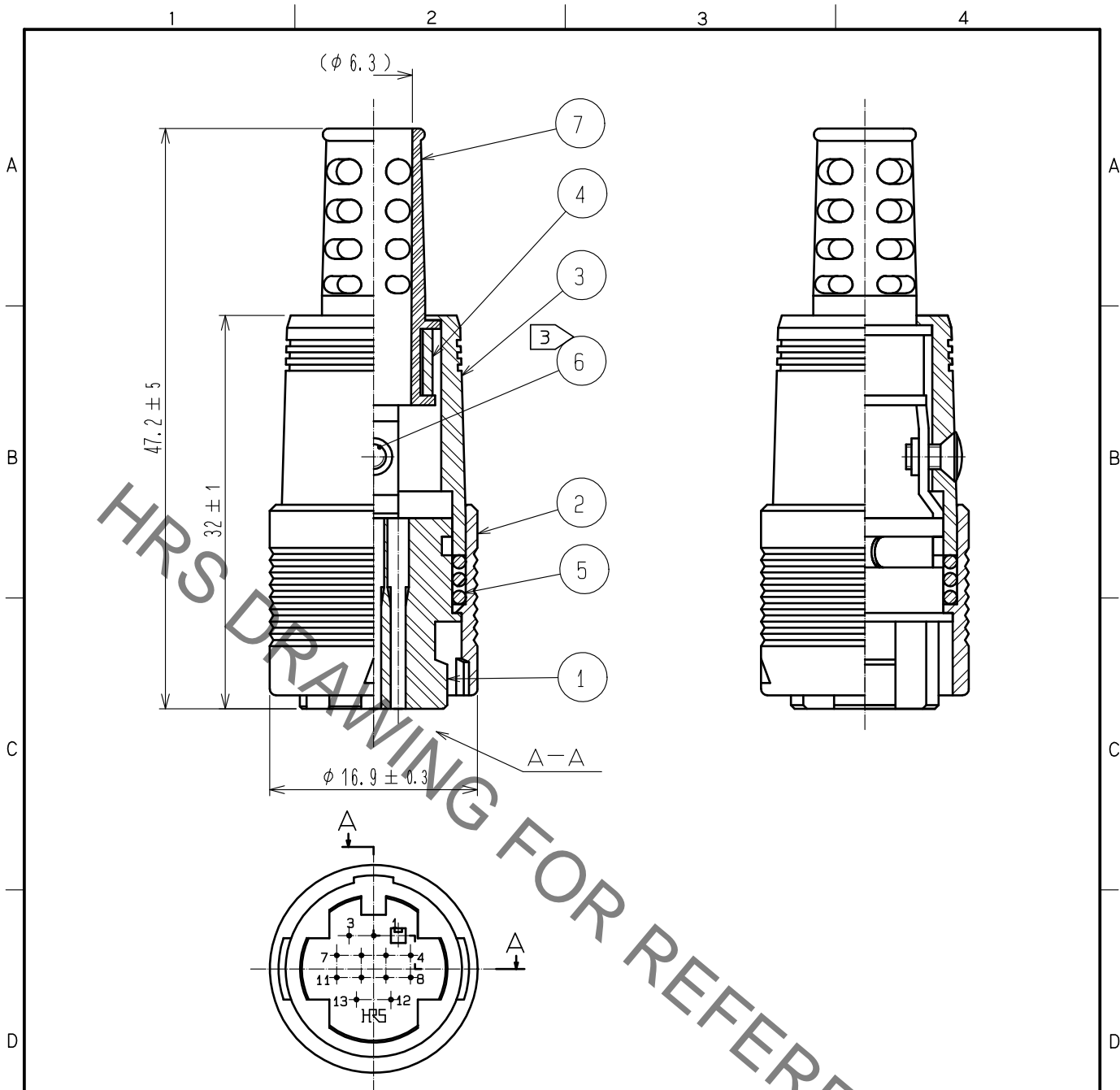

- Notes
- ① Applicable crimping contact:  
 Contact No.1 to 11 : RP13A-SC-222(Applicable wire : AWG #24 to 28)  
 Contact No.12 to 13 : RP13A-SC-212(Applicable wire : AWG #18 to 22)
  - 2 Applicable crimp contact crimping tool : RP13A-TC-01(CCL150-0070-0)  
 Applicable crimp contact extraction tool : RP13A-SC-TP(CCL150-0022-8)
  - ③ The recommended tightening torque of Ref. No. ⑥ shell be 0.2N·m.
  - 4 This product is delivered disassemble.
  - 5 The cable pull and twisting strength and other characteristics may differ.  
 Depending on the cable structure. please confirm before the use.

4	BRASS			7	PVC	(BLACK)	
3	POLYCARBONATE	(BLACK) UL94V-0		6	BRASS	ZINC PLATING BLACK CHROMETE TREATMENT (TRIVALENT CHROMIUM) JIS B 1111 M2X0.4X4	
2	POLYCARBONATE	(BLACK) UL94V-0		5	STEEL	NICKEL PLATING	
1	POLYCARBONATE	(BLACK) UL94V-0					
NO.	MATERIAL	FINISH .	REMARKS	NO.	MATERIAL	FINISH .	REMARKS

UNITS mm	SCALE	COUNT	DESCRIPTION OF REVISIONS	DESIGNED	CHECKED	DATE
2 : 1	① 1	DIS-C-00001211	MM. ISHII	EJ. KUNII	16.10.17	
APPROVED : MR. YOSHIDA 05.01.05			DRAWING NO. EDC4-009810-71			
CHECKED : MO. SATOH 05.01.05			PART NO. RP13A-12PA-13SC(71)			
DESIGNED : YH. YAMADA 05.01.05			CODE NO. CL113-0182-4-71			
DRAWN : YH. YAMADA 05.01.05			① 1/1			