

Oct.1.2019 Copyright 2019 HIROSE ELECTRIC CO., LTD. All Rights Reserved.  
 In case of consideration for using Automotive equipment / device which demand high reliability, kindly contact our sales window correspondents.

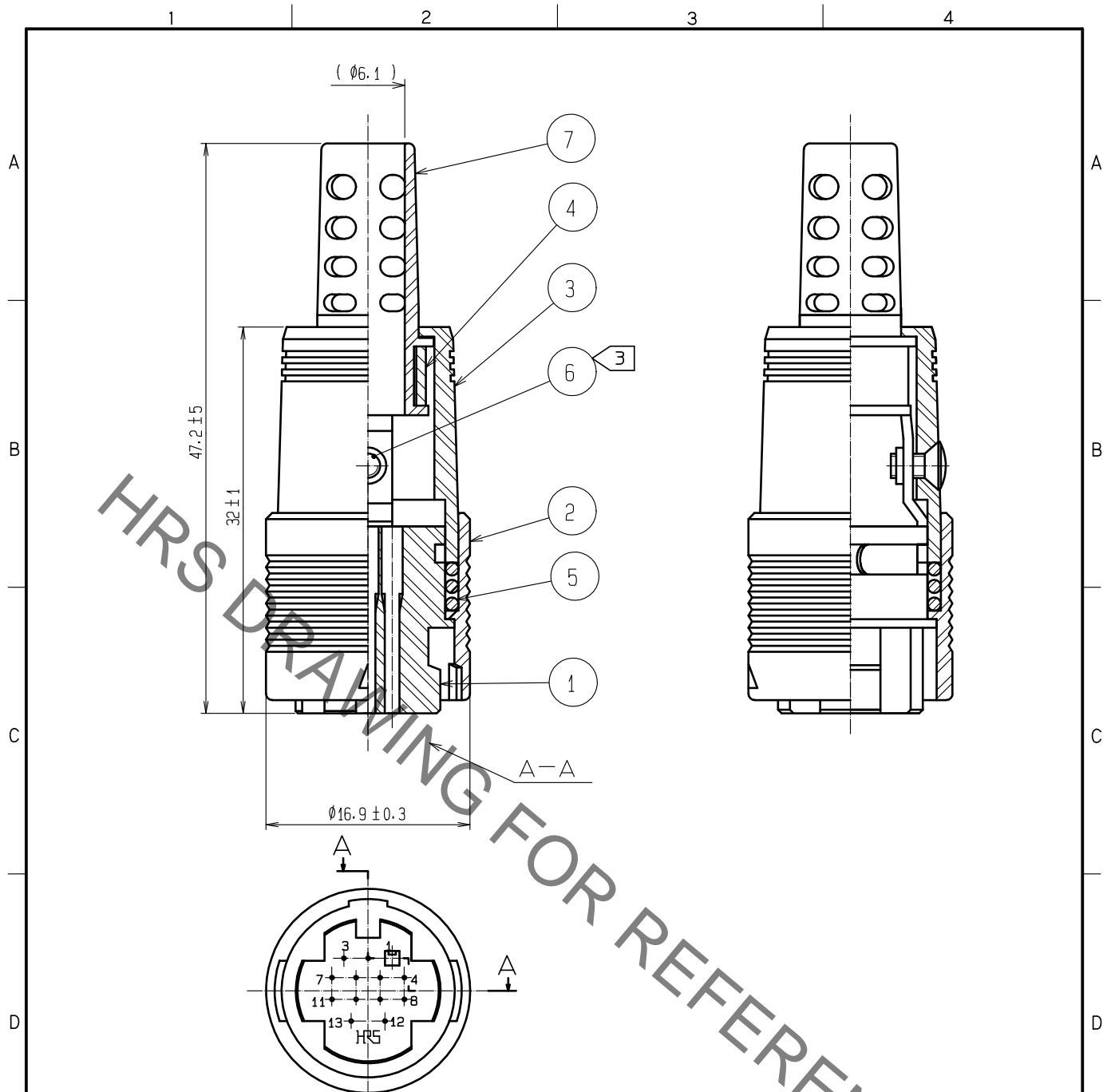

- NOTES
- 1 APPLICABLE CRIMP CONTACT:  
 CONTACT NO.1 TO 11: RP13A-SC-222(WIRE RANGE, #24 TO 28 AWG)  
 CONTACT NO.12 TO 13: RP13A-SC-212(WIRE RANGE, #18 TO 22 AWG)
  - 2 APPLICABLE CRIMP CONTACT CRIMPING TOOL: RP13A-TC-01(CL150-0070-0)  
 APPLICABLE CRIMP CONTACT EXTRACTION TOOL: RP13A-SC-TP(CL150-0022-8)
  - 3 THE RECOMMENDED CLAMP TORQUE OF REF.NO. ⑥ TO 0.2 N · m.
  - 4 THIS PRODUCT IS DELIVERED DISASSEMBLED.
  - 5 THE CABLE CLAMP STRENGTH, ROTATION STRENGTH AND OTHER PLEASE CONFIRM BEFORE THE USE.

4	BRASS				
3	POLYCARBONATE	(BLACK) UL94V-0	7	PVC	(BLACK)
2	POLYCARBONATE	(BLACK) UL94V-0	6	BRASS	ZINC PLATING BLACK CHROME TREATMENT (TRIVALENT CHROMIUM) JIS B 1111 M2X0.4X4
1	POLYCARBONATE	(BLACK) UL94V-0	5	STEEL	NICKEL PLATING
NO.	MATERIAL	FINISH . REMARKS	NO.	MATERIAL	FINISH . REMARKS

UNITS mm	SCALE 2 : 1	COUNT	DESCRIPTION OF REVISIONS	DESIGNED	CHECKED	DATE
HIROSE ELECTRIC CO., LTD.			APPROVED :HY. KOBAYASHI 18.02.26 CHECKED :HY. KOBAYASHI 18.02.26 DESIGNED :DS. MATSUNE 18.02.24 DRAWN :AI. NISHIYAMA 18.02.16	DRAWING NO. EDC-009829-31-00 PART NO. RP13A-12PB-13SC(31) CODE NO. CL113-0184-0-31	1/1	