

Sep.1.2019 Copyright 2019 HIROSE ELECTRIC CO., LTD. All Rights Reserved.
 In case of consideration for using Automotive equipment / device which demand high reliability, kindly contact our sales window correspondents.

1					2					3					4				
COUNT	DESCRIPTION OF REVISIONS				BY	CHKD	DATE	COUNT	DESCRIPTION OF REVISIONS				BY	CHKD	DATE				
△								△											
△								△											
△								△											

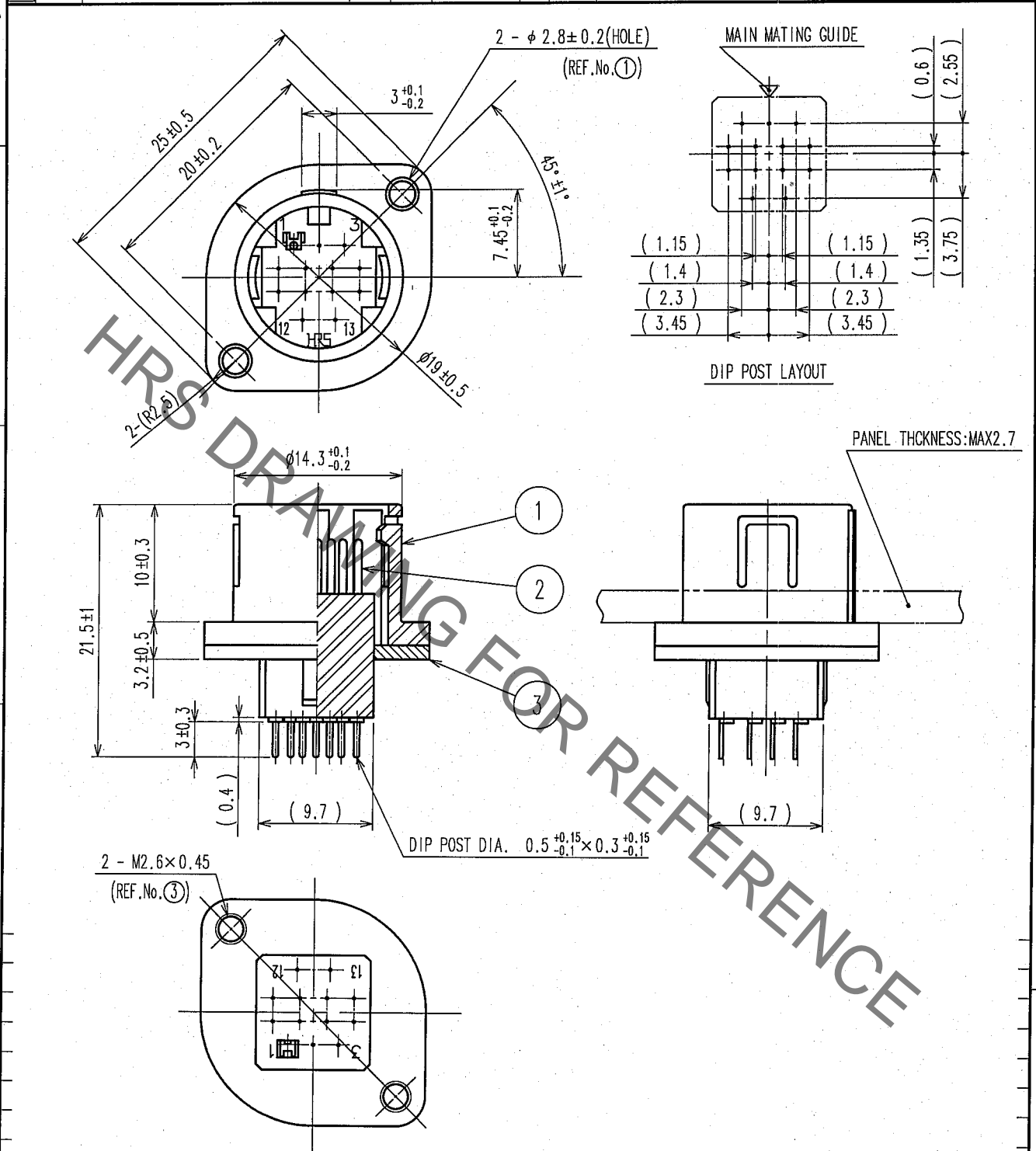

2	PHOSPHOR BRONZE	SILVER PLATING	0.8μ m min.				
1	POLYCARBONATE	(BLACK)	UL94V-0	3	STEEL	NICKEL PLATING	
NO.	MATERIAL	FINISH, REMARKS		NO.	MATERIAL	FINISH, REMARKS	

CODE NO. (OLD) CL				DRAWN M. Ishihara 05.9.26	DESIGNED E. Yamino 05.09.26	CHECKED H. Zemba 05.09.26	APPROVED M. Sato 05.09.28	RELEASED
----------------------	--	--	--	---------------------------------	-----------------------------------	---------------------------------	---------------------------------	----------

F SCALE 2 : 1 UNITS mm	DRAWING NO. EDC4-010245-71	PART NO. RP13A-12RA-13PA(71)	CODE NO. CL113-0202-0-71 1/1
	HIROSE ELECTRIC CO., LTD.		
	FORM NO. 228		