

Oct.1.2019 Copyright 2019 HIROSE ELECTRIC CO., LTD. All Rights Reserved.
 In case of consideration for using Automotive equipment / device which demand high reliability, kindly contact our sales window correspondents.

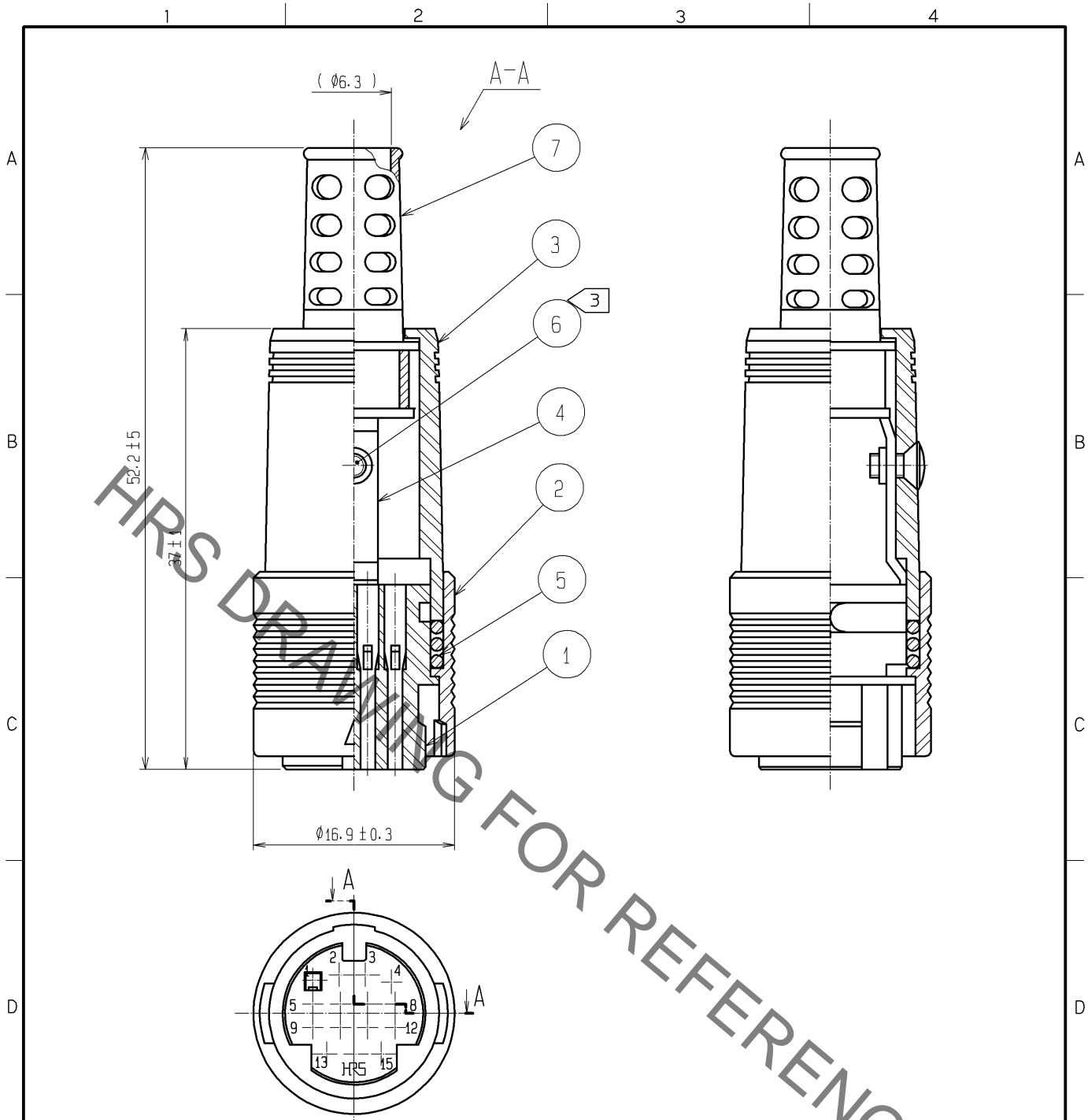

- NOTES
- 1 APPLICABLE CRIMPING CONTACT : RP13A-SC-222(CL113-0151-0-00)
(APPLICABLE WIRE : #24~#28)
 - 2 APPLICABLE CRIMP CONTACT EXTRACTION TOOL : RP13A-SC-TP(CL150-0022-8-00)
 - 3 THE RECOMMENDED TIGHTENING TORQUE OF REF. NO. ◎SHELL BE 0.2N · m.
 - 4 THIS PRODUCT IS DELIVERED DISASSEMBLE.
 - 5 THE CABLE PULL AND TWISTING STRENGTH AND OTHER CHARACTERISTICS MAY DIFFER, DEPENDING ON THE CABLE STRUCTURE. PLEASE CONFIRM BEFORE THE USE.

4	BRASS						
3	POLYCARBONATE	(BLACK) UL94V-0		7	FLEXIBLE POLYVINYLCHLORIDE	(BLACK)	
2	POLYCARBONATE	(BLACK) UL94V-0		6	BRASS	BLACK CHROMATE TREATMENT(TRIVALENT CHROMIUM) JIS B1111 M2×0.4×4	
1	POLYCARBONATE	(BLACK) UL94V-0		5	STEEL	NICKEL PLATING	
NO.	MATERIAL	FINISH	REMARKS	NO.	MATERIAL	FINISH	REMARKS

UNITS mm	SCALE 2 : 1	COUNT	DESCRIPTION OF REVISIONS	DESIGNED	CHECKED	DATE	
HIROSE ELECTRIC CO., LTD.			APPROVED : EJ. KUNII 12.08.06 CHECKED : HY. KISHI 12.08.06 DESIGNED : HK. NAMAI 12.08.06 DRAWN : HK. NAMAI 12.08.06	DRAWING NO. EDC4-009932-71 PART NO. RP13A-12PD-15SC(71) CODE NO. CL113-0206-0-71			1/1