

Jan.1.2025 Copyright 2025 HIROSE ELECTRIC CO., LTD. All Rights Reserved.
 In case of consideration for using Automotive equipment / device which demand high reliability, kindly contact our sales window correspondents.

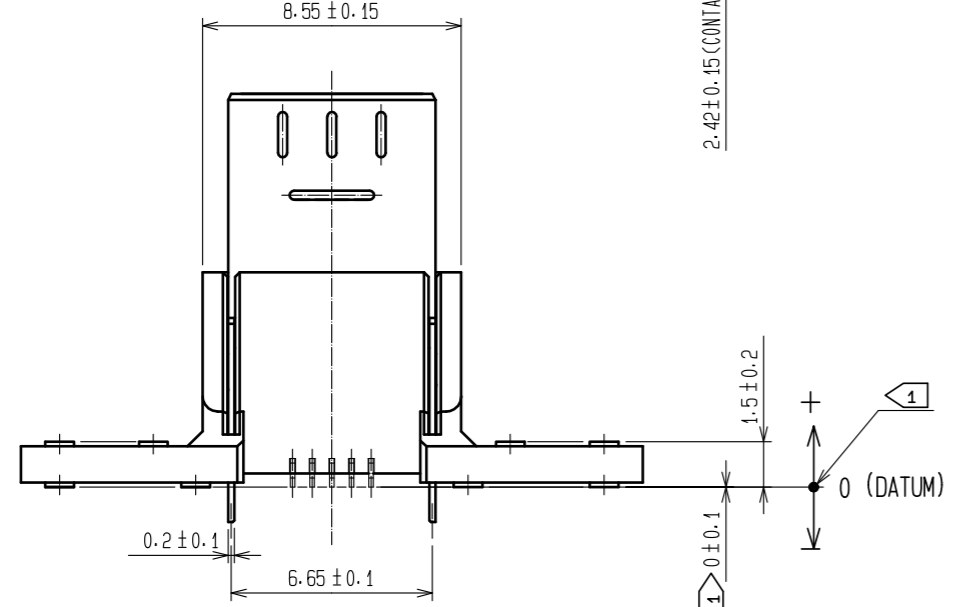

RECOMMENDED PC BOARD PATTERN

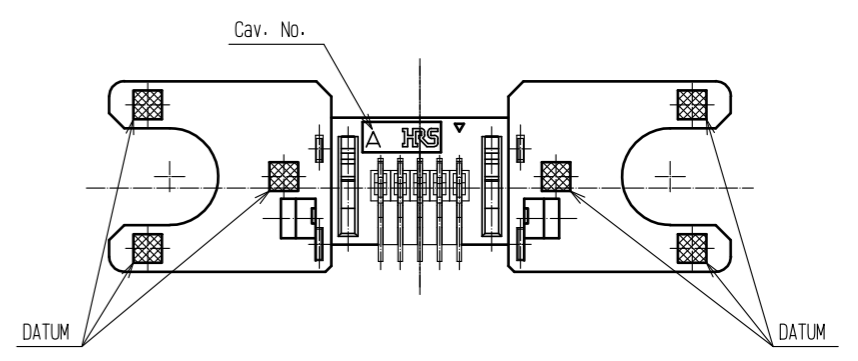
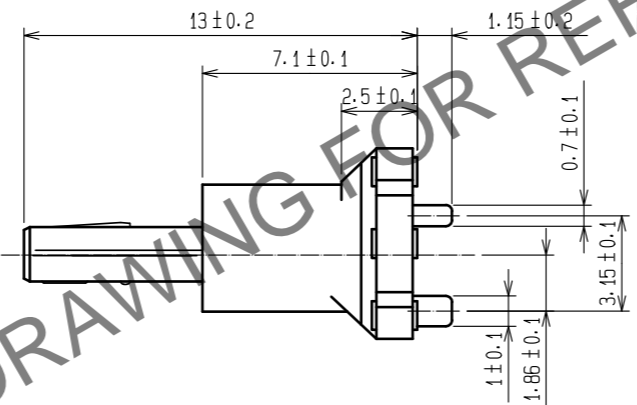
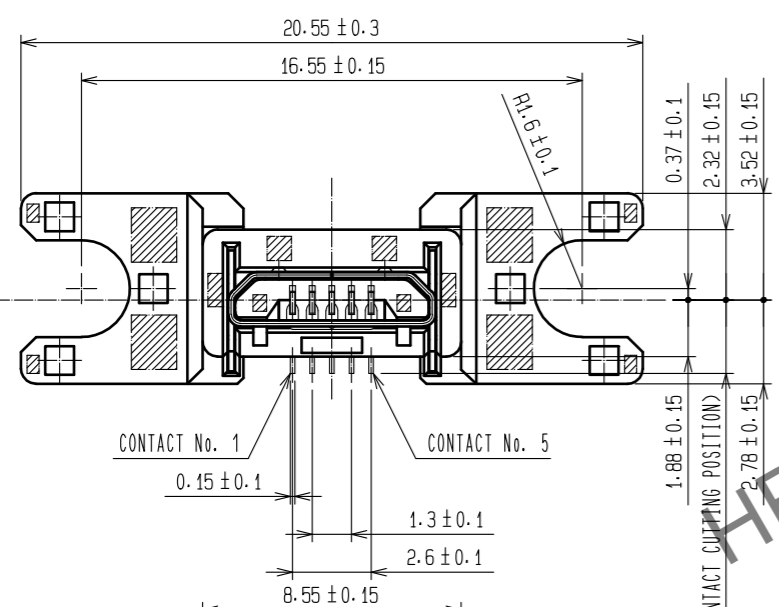
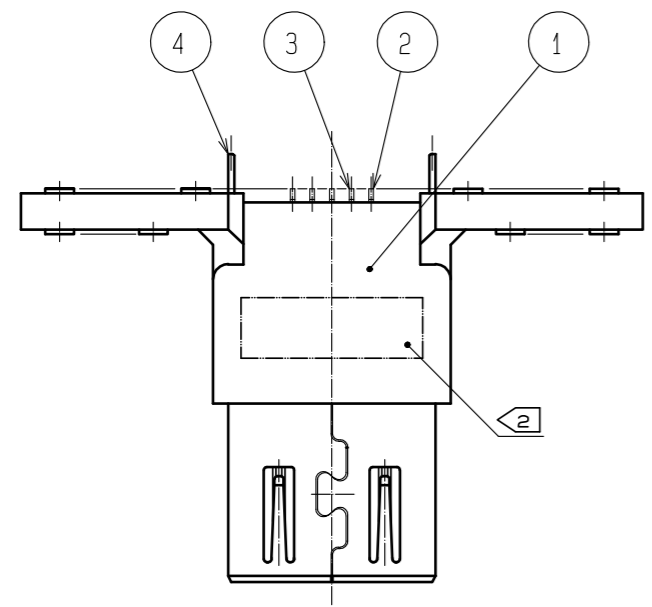
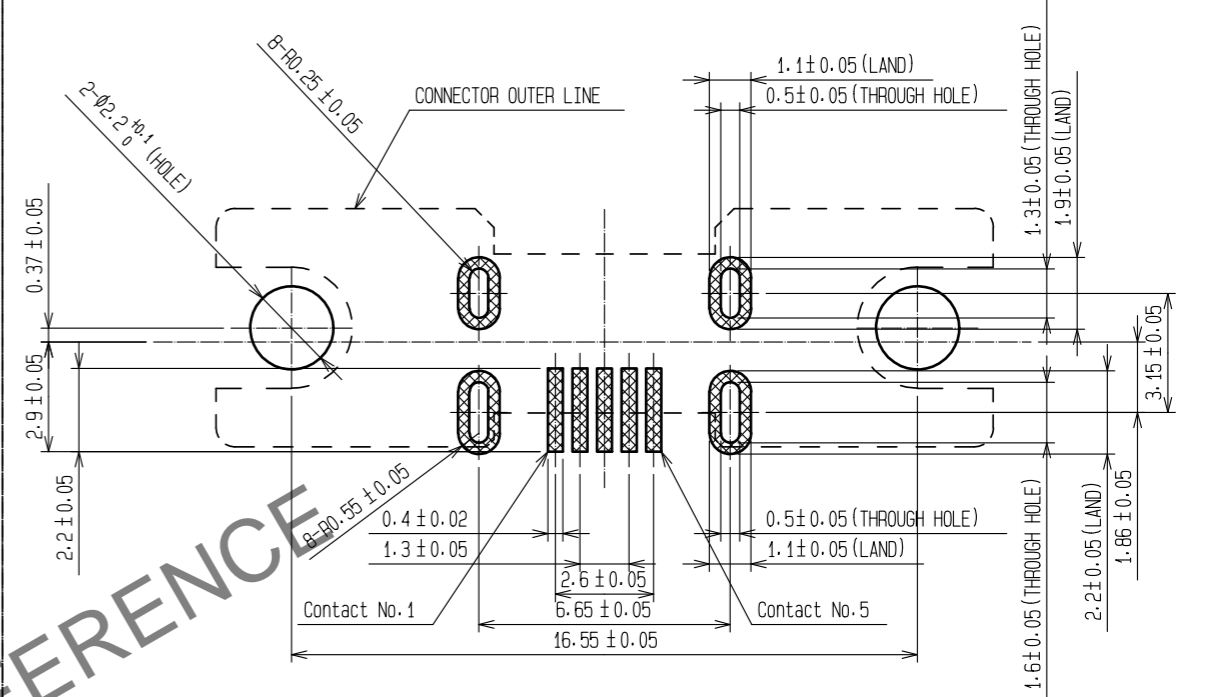

3	COPPER ALLOY	5	7	PE				
2	COPPER ALLOY	5	6	PS				
1	POLYAMIDE OR LCP	BLACK UL94V-0	5	POLYAMIDE OR LCP	BLACK			
			4	STAINLESS STEEL	SELECTIVE TIN PLATING 1 μm MIN.			
NO.	MATERIAL	FINISH . REMARKS	NO.	MATERIAL	FINISH . REMARKS			
UNITS	mm	SCALE	4 : 1	COUNT	DESCRIPTION OF REVISIONS	DESIGNED	CHECKED	DATE
APPROVED		.NM. NISHIMATSU		15. 10. 27		DRAWING NO. EDC-126145-31-00		
CHECKED		.KN. ICHIKAWA		15. 10. 27		PART NO. ZX80-B-5SA(31)		
DESIGNED		.TS. ITO		15. 10. 27		CODE NO. CL242-0019-7-31		
DRAWN		.AK. AKIYAMA		15. 10. 27		1/2		

Jan.1.2025 Copyright 2025 HIROSE ELECTRIC CO., LTD. All Rights Reserved.
 In case of consideration for using Automotive equipment / device which demand high reliability, kindly contact our sales window correspondents.

3 DRAWING FOR PACKING(FREE)

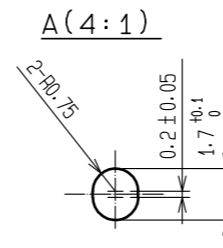
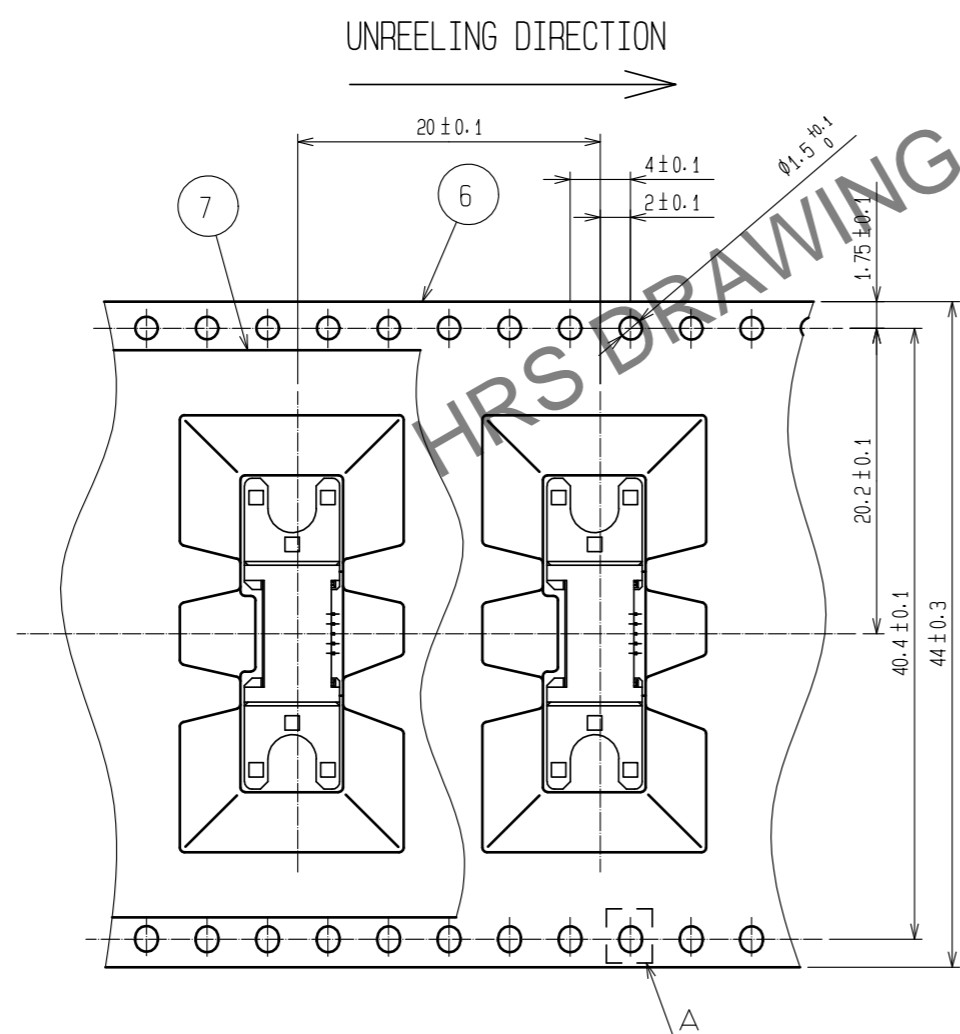
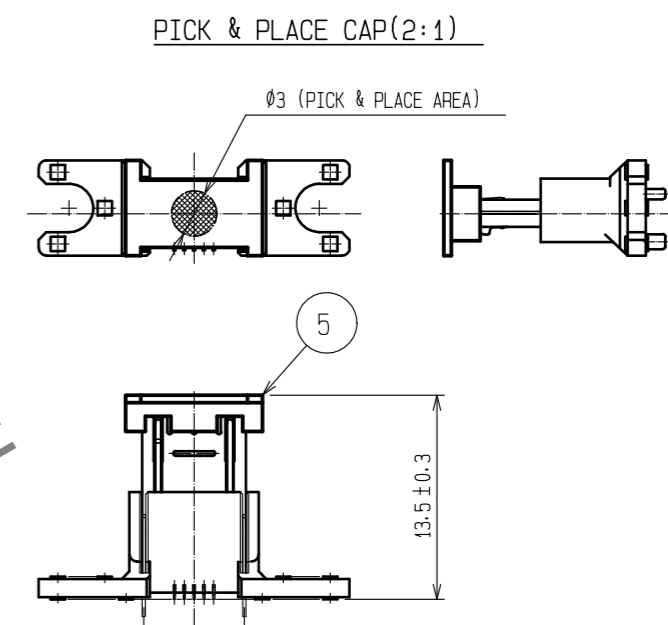
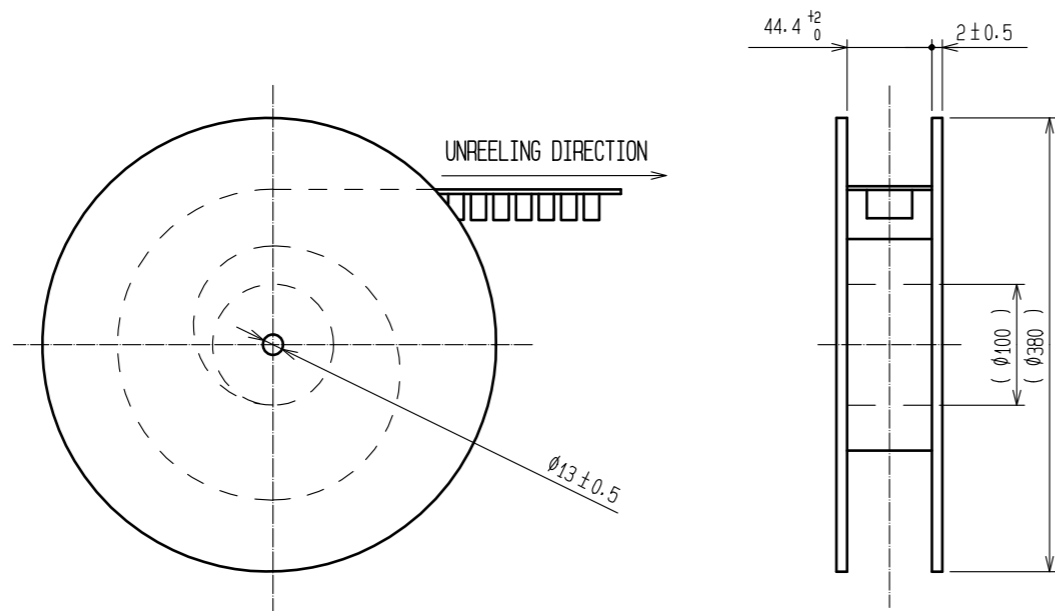

NOTES. 1 DIMENSIONS OF SMT RANGE AND CO-PLANARITY ARE AS SHOWN BELOW.

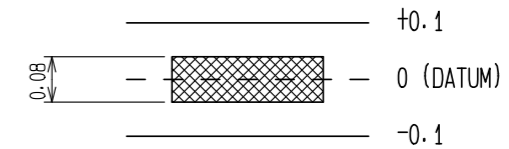

- 2 LOT No. SHALL BE INDICATED AT THE POSITION AS SHOWN.
- 3 PER REEL: 200 pcs.
- 4 THE SHADED AREAS SHOW LOCATIONS OF EJECTOR PINS.
- 5 PLATING
 CONTACT AREA : GOLD 0.75μm MIN.
 READ AREA : GOLD 0.03μm MIN.
 UNDER PLATING: NICKEL 2μm MIN.

HRS	DRAWING NO.	EDC-126145-31-00
	PART NO.	ZX80-B-5SA(31)
	CODE NO.	CL242-0019-7-31
		2/2