

Apr.1.2019 Copyright 2019 HIROSE ELECTRIC CO., LTD. All Rights Reserved.
In case of consideration for using Automotive equipment / device which demand high reliability, kindly contact our sales window correspondents.

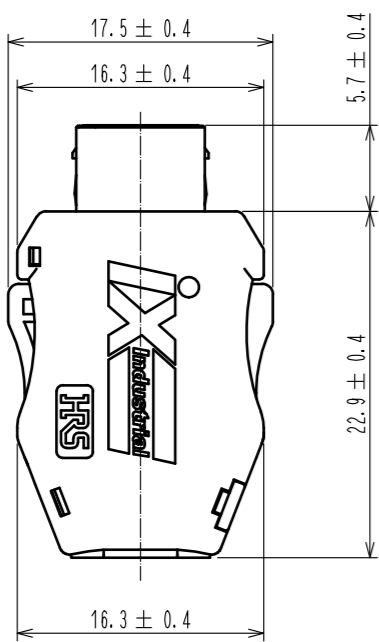

Notes. 1. Applicable cable condition is shown below.
In case of using a not applicable cable, please contact our sales representative.
Refer to the technical specification (ETAD-E3164-00) for wiring and assembly procedure.

Applicable Cable	
Items	Applicable Condition
Conductor size	AWG # 28-22
Insulation O.D.	φ 1.55 mm MAX.
Braid Shield	Tin plating
Sheath O.D.	φ 6.3 -7.2 mm

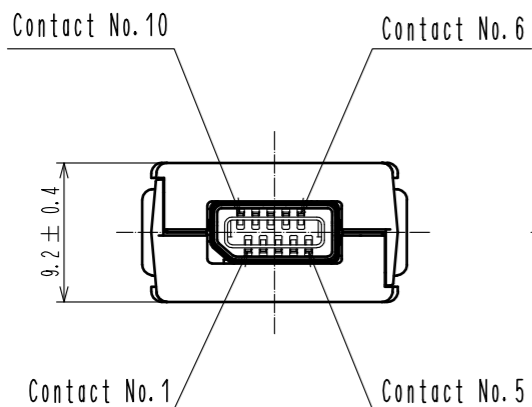
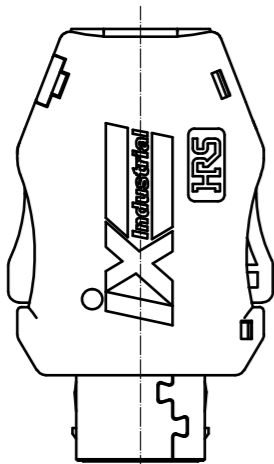
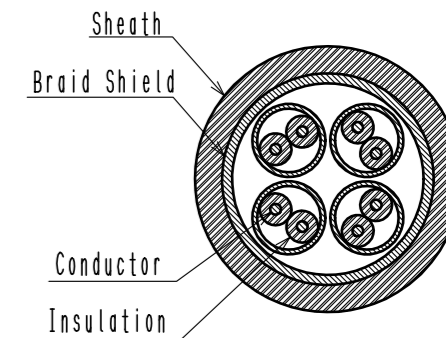

2 This product (Type A) is defined for 10/100 Mbit/s and 1/10 Gbit/s Ethernet communication. Please use Type B for all other non Ethernet applications like signaling, serial or other industrial bus communication systems.

Mating Shape

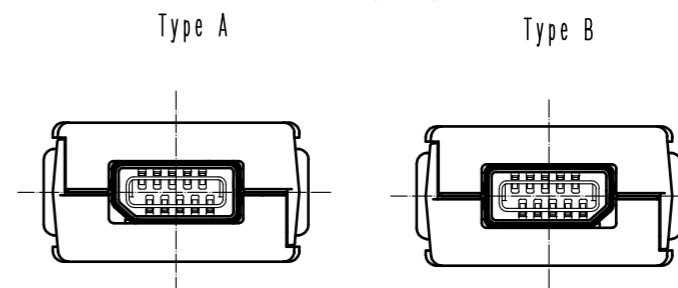

3 This product except plug unit is packed separately by the types of parts.
Shield Shell is packed in pre-bended state. (See next page.)

2 Pin Assignment For 10/100 Mbit/s And 1/10 Gbit/s Ethernet

Contact No.	Signal	
	10/100 Mbit/s	1/10 Gbit/s
1	TX+	BI_DA+
2	TX-	BI_DA-
3	N.C	N.C
4	N.C	BI_DC+
5	N.C	BI_DC-
6	RX+	BI_DB+
7	RX-	BI_DB-
8	N.C	N.C
9	N.C	BI_DD+
10	N.C	BI_DD-

3	Stainless Steel		7	PC	Dark gray, UL94V-0
2	PA	Black, UL94V-0	6	Stainless Steel	Nickel 0.2 μm min
1	Copper Alloy	Contact area : Palladium-Nickel 0.75 μm min + Gold 0.05 μm min Wiring area : Gold 0.03 μm min Under plating : Nickel 2 μm min	5	Stainless Steel	Nickel 1 μm min
			4	PA	Black, UL94V-0
NO.	MATERIAL	FINISH . REMARKS	NO.	MATERIAL	FINISH . REMARKS
UNITS mm		SCALE 2 : 1	COUNT 2	DESCRIPTION OF REVISIONS DIS-E-00001437	
DESIGNED SG. CHAMURA		CHECKED KI. NAGANUMA		DATE 18.07.02	
APPROVED : RI. TAKAYASU 17.04.11		DRAWING NO. EDC-129431-01-00			
CHECKED : KI. NAGANUMA 17.04.11		PART NO. IX40G-A-10S-CV(7.0)(01)			
DESIGNED : TS. SAKAIZAWA 17.04.11		CODE NO. CL251-0022-0-01			
DRAWN : TS. SAKAIZAWA 17.04.11					

Apr.1.2019 Copyright 2019 HIROSE ELECTRIC CO., LTD. All Rights Reserved.
 In case of consideration for using Automotive equipment / device which demand high reliability, kindly contact our sales window correspondents.

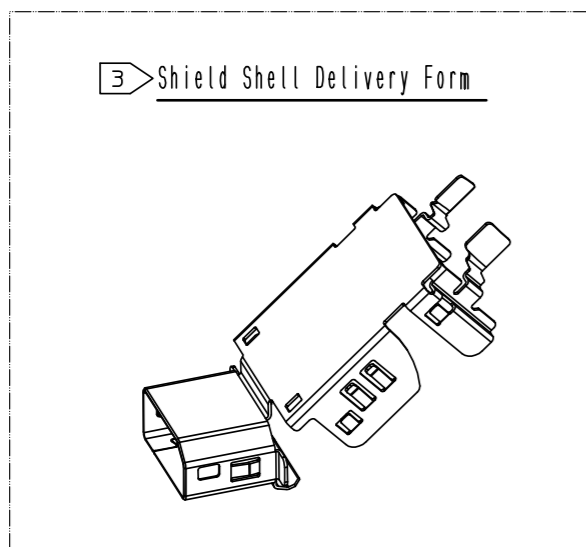

HRS DRAWING FOR REFERENCE

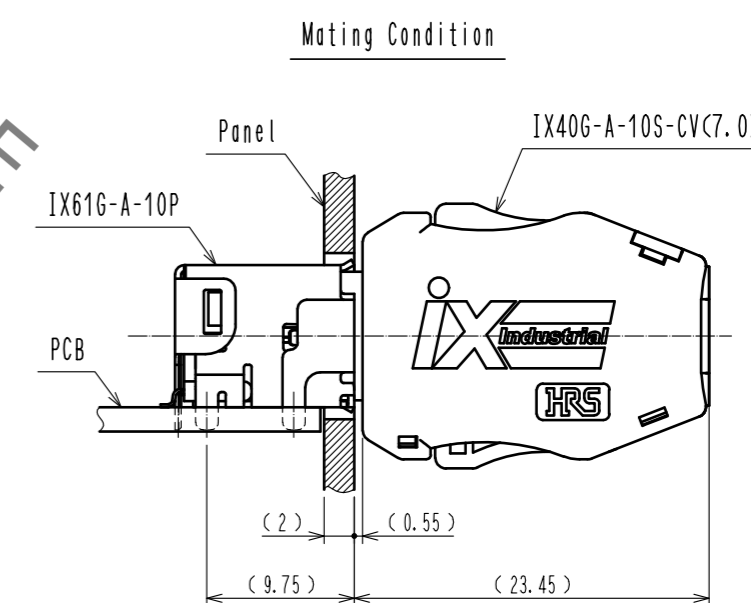
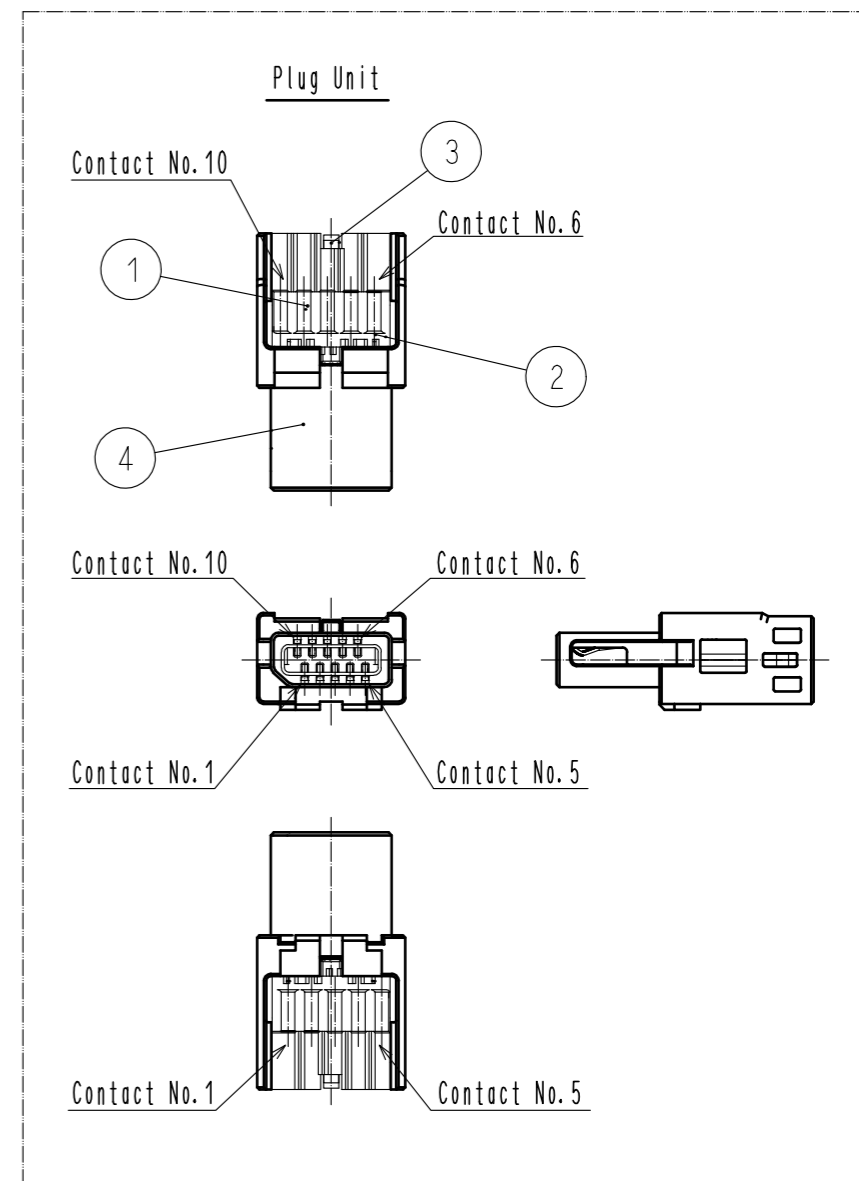
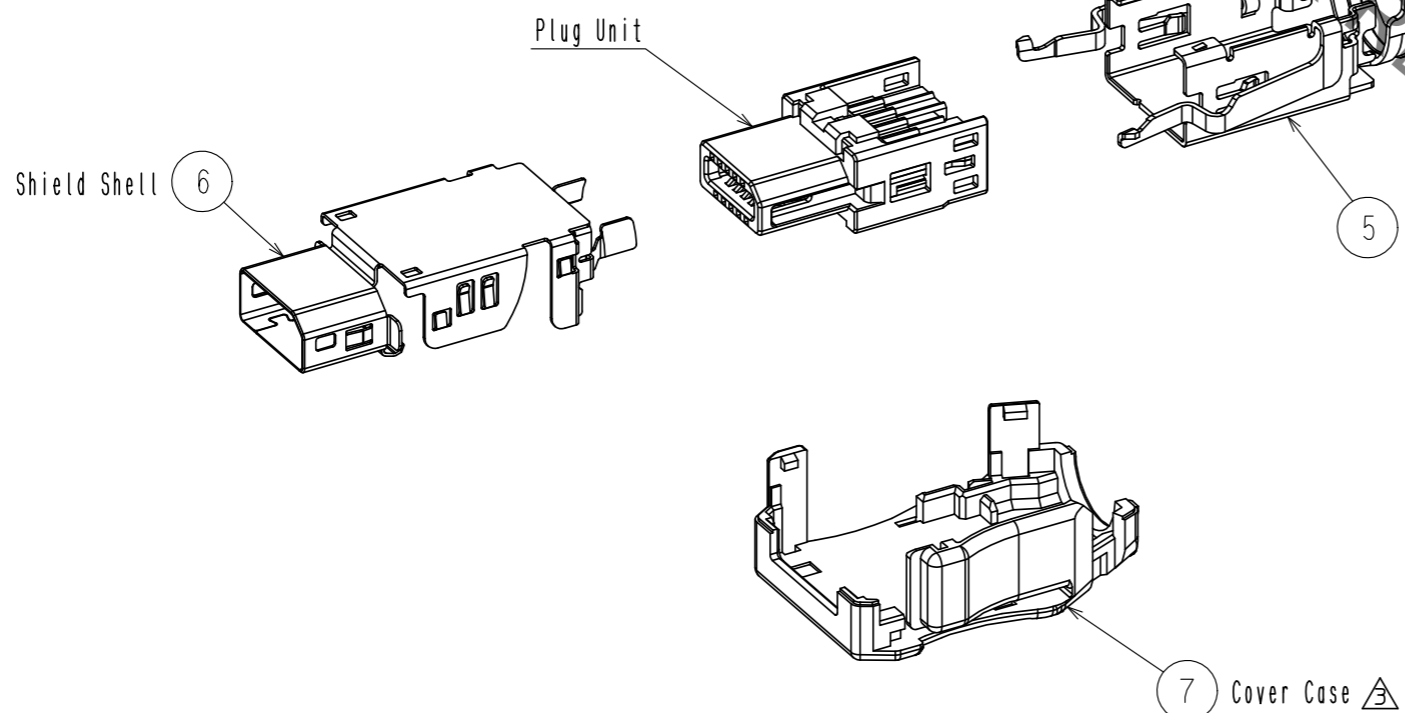
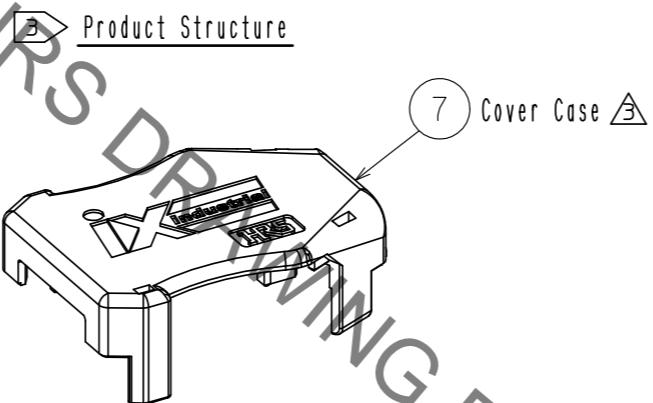

HRS	DRAWING NO.	EDC-129431-01-00
	PART NO.	IX40G-A-10S-CV(7.0)(01)
	CODE NO.	CL251-0022-0-01
		3/2