

Apr.1.2019 Copyright 2019 HIROSE ELECTRIC CO., LTD. All Rights Reserved.  
In case of consideration for using Automotive equipment / device which demand high reliability, kindly contact our sales window correspondents.

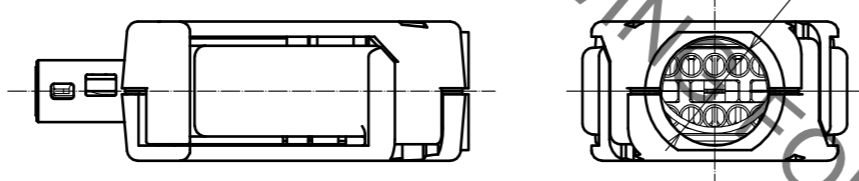
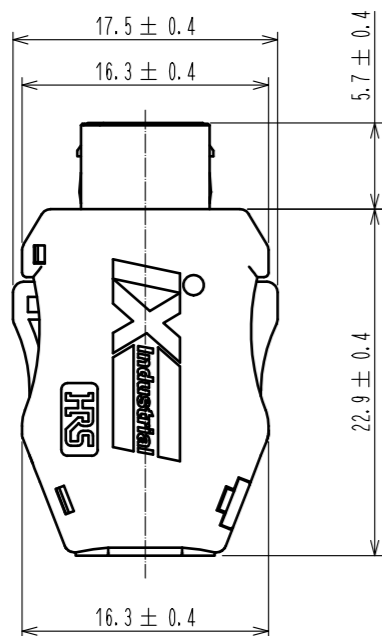
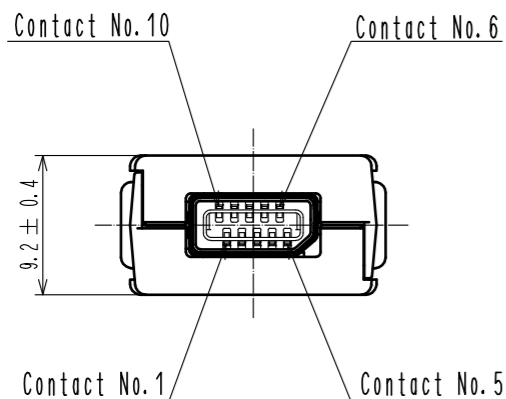
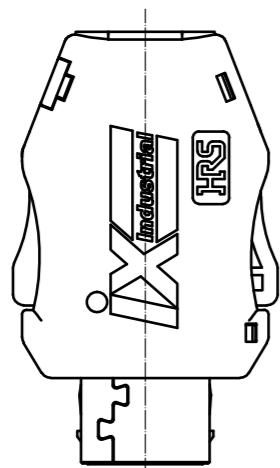

Notes. 1. Applicable cable condition is shown below.  
In case of using a not applicable cable, please contact our sales representative.  
Refer to the technical specification (ETAD-E3162-00) for wiring and assembly procedure.

Applicable Cable

Items		Applicable Condition
Conductor	Size	AWG24
	Composition	7 stranded
	Material	Annealed copper wire
Insulation O. D.		φ1.1 to 1.25mm
Braid Shield		Tin plating
Sheath O. D.		φ6.3 to 7.2mm

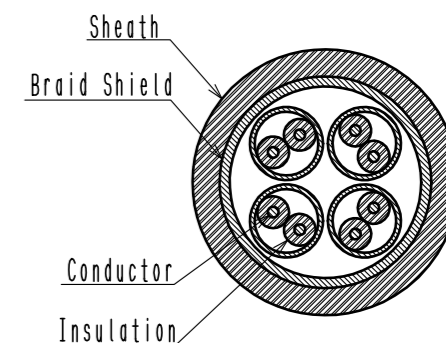

2. This product (Type B) is used for non Ethernet applications like signaling, serial or other industrial bus communication systems. Please use Type A for 10/100Mbit/s and 1/10 Gbit/s Ethernet communication.

Mating Shape

Type A

Type B

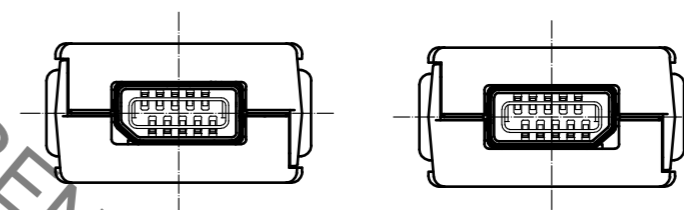

③ This product except plug unit is packed separately by the types of parts. Shield Shell is packed in pre-bended state. (See next page.)

3	Stainless Steel		8	PC	Dark gray, UL94V-0
2	PA	Dark gray, UL94V-0	7	Stainless Steel	Nickel 0.2 μm min
1	Copper Alloy	Contact area : Palladium-Nickel 0.75 μm min + Gold 0.05 μm min	6	Stainless Steel	Nickel 1 μm min
		Wiring area : Gold 0.03 μm min	5	PC	Clear yellow, UL94V-0
		Under plating : Nickel 2 μm min	4	PA	Black, UL94V-0
NO.	MATERIAL	FINISH . REMARKS	NO.	MATERIAL	FINISH . REMARKS
UNITS mm		SCALE 2 : 1	COUNT 2	DESCRIPTION OF REVISIONS DIS-E-00001437	
APPROVED : RI. TAKAYASU 17.03.28			DESIGNED SG. CHAMURA		
CHECKED : KI. NAGANUMA 17.03.28			CHECKED KI. NAGANUMA		
DESIGNED : HT. SATO 17.03.28			DATE 18.07.02		
DRAWN : HT. SATO 17.03.28			DRAWING NO. EDC-129486-01-00		
HRS HIROSE ELECTRIC CO., LTD.			PART NO. IX316-B-10S-CV(7.0)(01)		
			CODE NO. CL251-0024-0-01		
			③ 1/2		

Apr.1.2019 Copyright 2019 HIROSE ELECTRIC CO., LTD. All Rights Reserved.  
 In case of consideration for using Automotive equipment / device which demand high reliability, kindly contact our sales window correspondents.

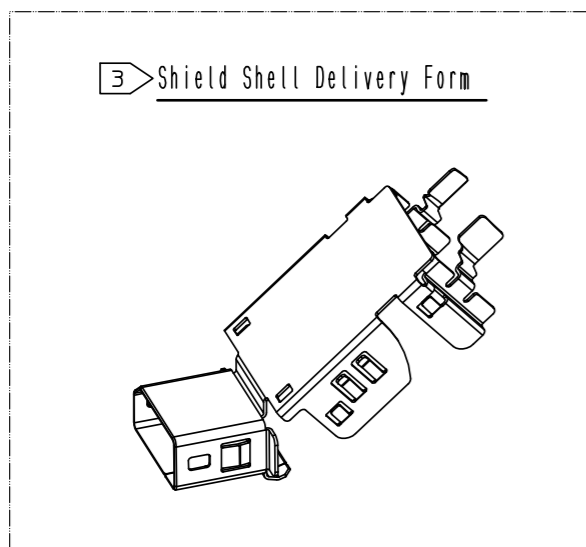

Product Structure

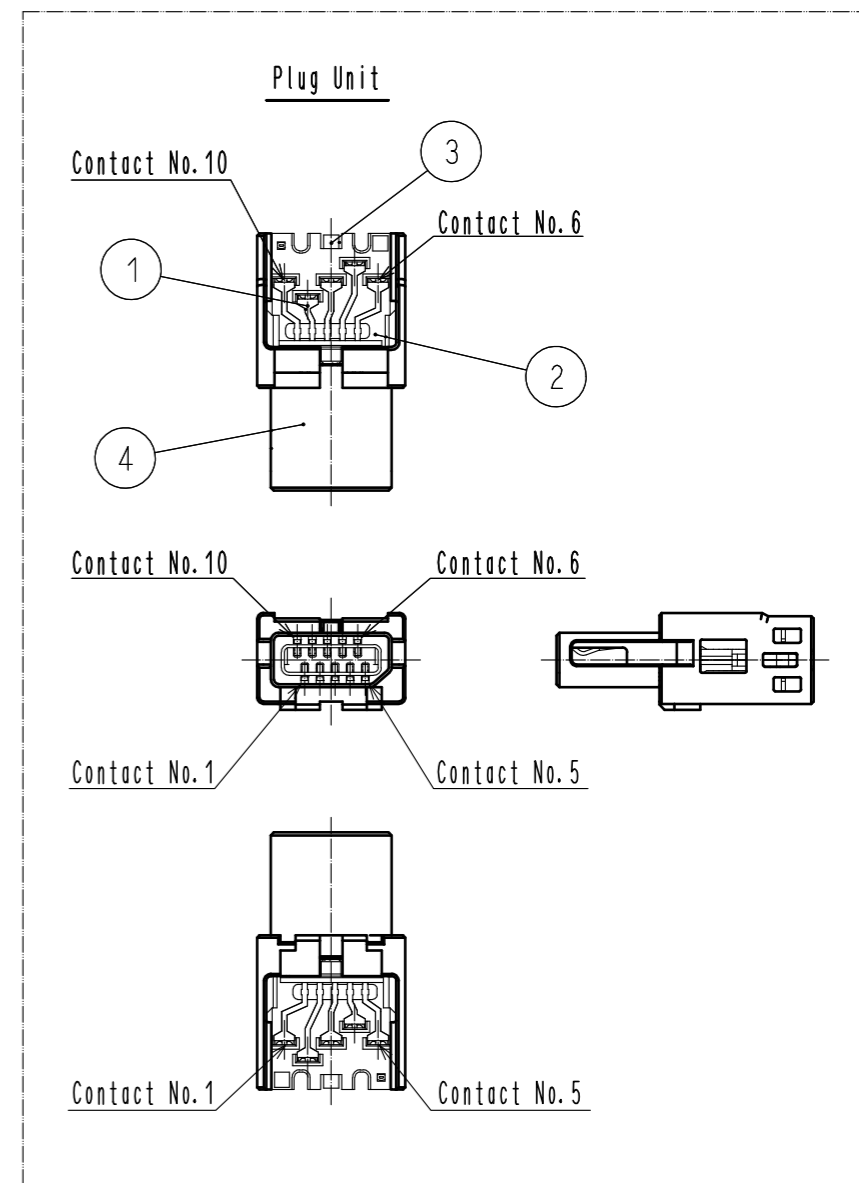
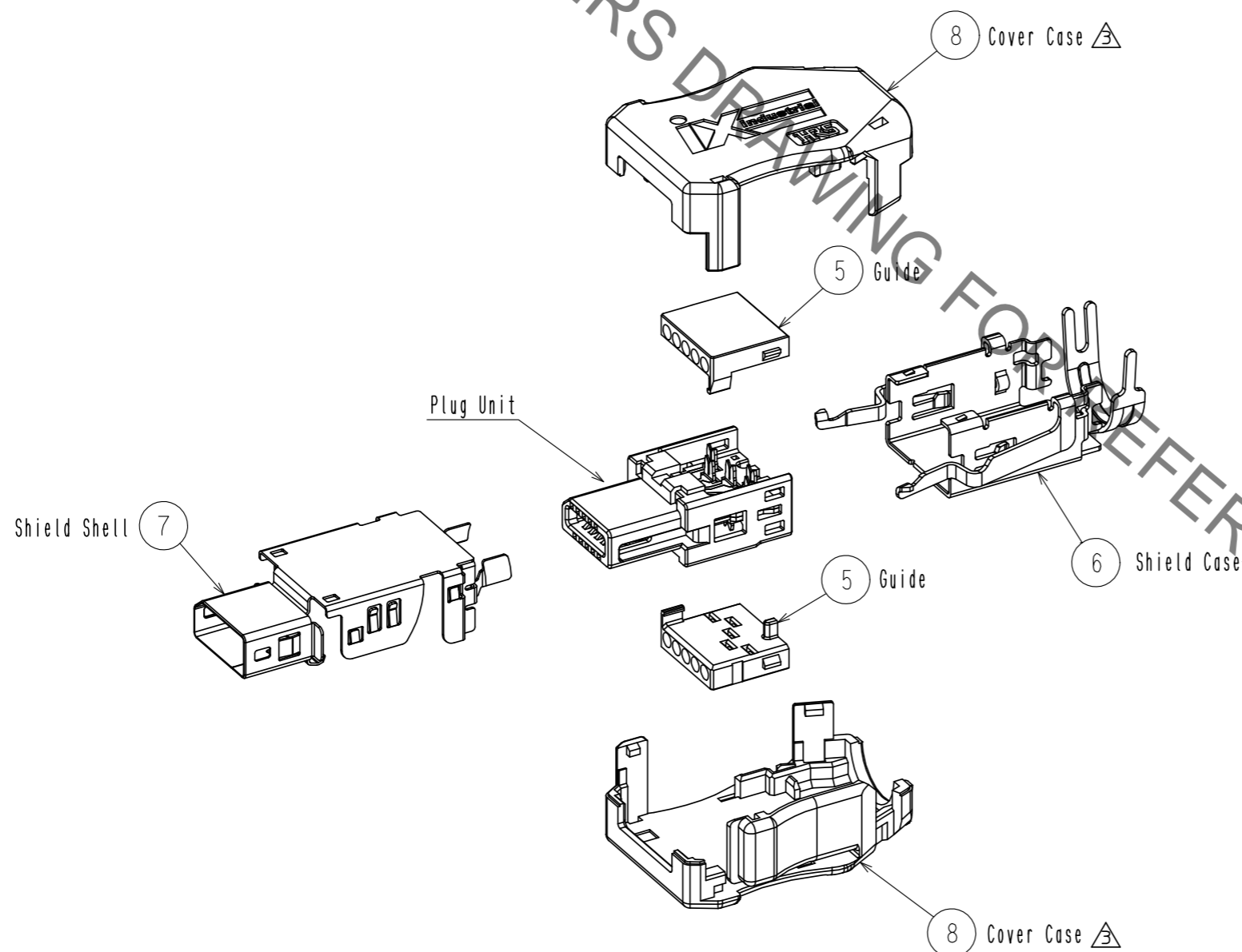

Mating Condition

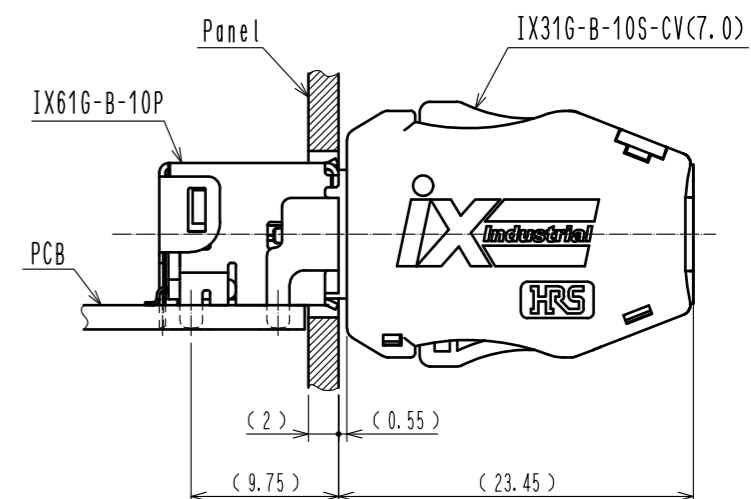

<b>HRS</b>	DRAWING NO.	EDC-129486-01-00
	PART NO.	IX31G-B-10S-CV(7.0)(01)
	CODE NO.	CL251-0024-0-01
		$\triangle$ 2/2