

Apr.1.2020 Copyright 2020 HIROSE ELECTRIC CO., LTD. All Rights Reserved.
 of consideration for using Automotive equipment / device which demand high reliability, kindly contact our sales window correspondents.

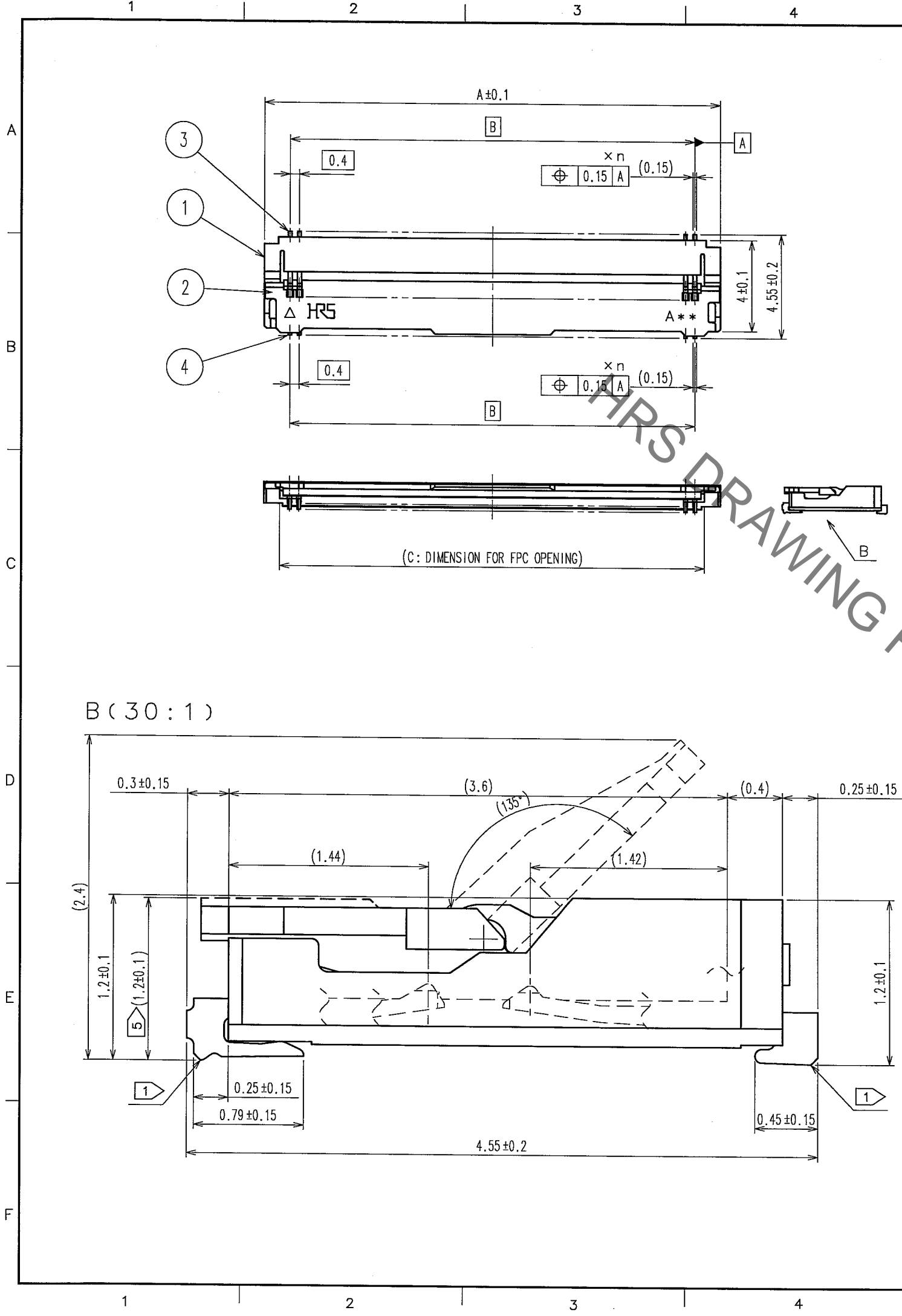

COUNT	DESCRIPTION OF REVISIONS	BY	CHKD	DATE	COUNT	DESCRIPTION OF REVISIONS	BY	CHKD	DATE
7	DIS-F-002121	T.M	N.N	07.06.27					

4 RECOMMENDED LAND PATTERN (SCALE:FREE)
 RECOMMENDED METAL MASK THICKNESS: $t=0.12$

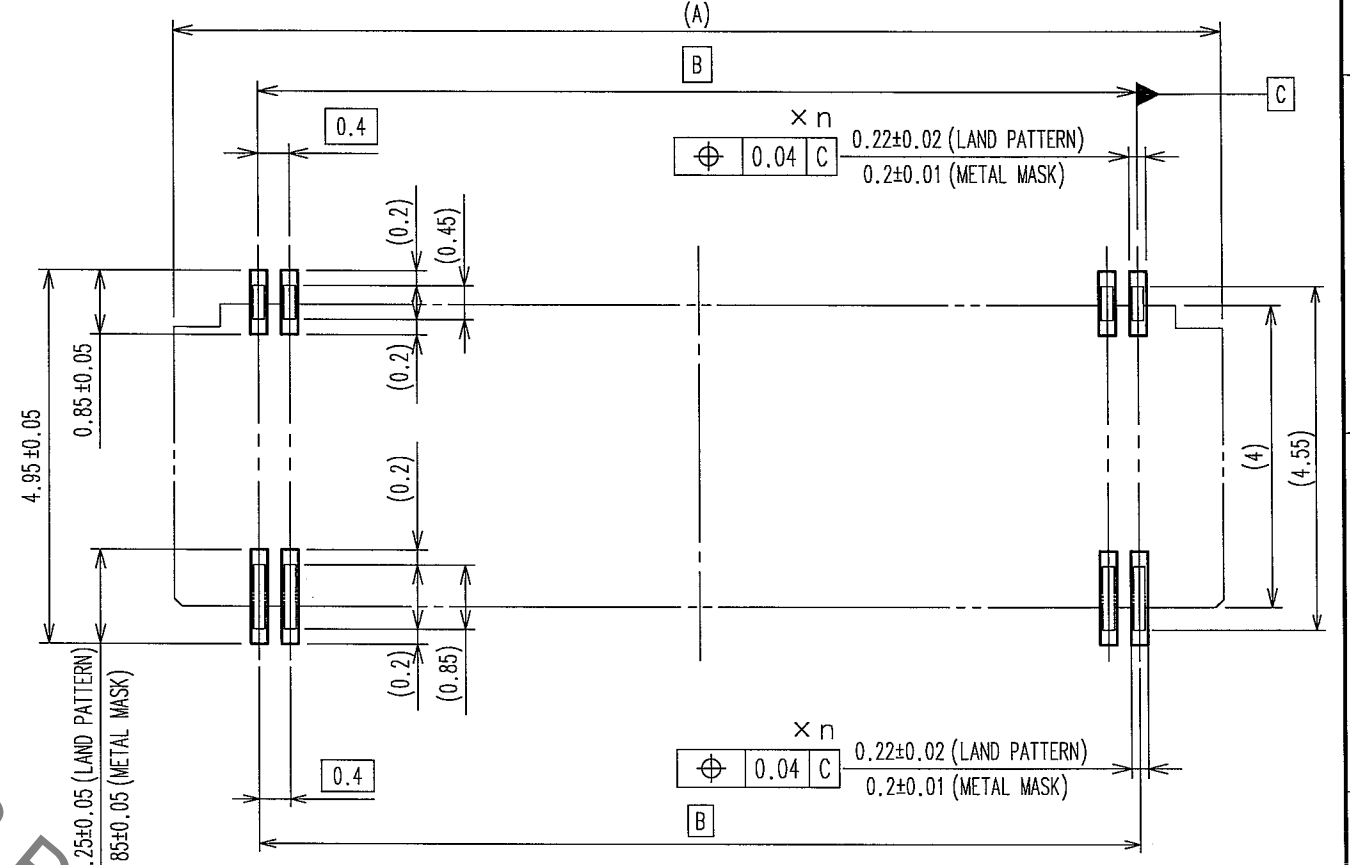

- NOTE
- LEAD CO-PLANARITY SHALL BE 0.1 MAX.
 - TO BE DELIVERED WITH TAPE AND REEL PACKAGES. SEE ATTACHED PACKAGING SPECIFICATIONS FOR DETAILS.
 - THE QUALITY REMAINS GOOD, EVEN WITH THE DARK SPOTS, WHICH COULD OCCASIONALLY OCCUR ON MOLDED PLASTIC.
 - RECOMMENDED LAND PATTERN DIMENSION IS AN EXAMPLE. THE DIMENSION DEPENDS ON MOUNTING REQUIREMENTS (SOLDER PASTE, PCB SIZE, AND TEMPERATURE PROFILE). THEREFORE, PLEASE CONFIRM THE MOUNTING CONDITION BEFORE USE.
 - IN CASE OF THE CONNECTOR OVER 92PINS, THE MOLD FOR LOCK LEVER SHOULD BE DOTTED LINE.

2	PA	DEEP BROWN	UL94V-0	4	PHOSPHOR BRONZE	GOLD FLASH OVER NICKEL 1 μ m MIN		
1	LCP	BEIGE	UL94V-0	3	PHOSPHOR BRONZE	GOLD FLASH OVER NICKEL 1 μ m MIN		
NO.	MATERIAL	FINISH, REMARKS		NO.	MATERIAL	FINISH, REMARKS		
CODE NO. (OLD) CL				DRAWN	DESIGNED	CHECKED	APPROVED	RELEASED
				T.MOGI 07.04.19	T.MOGI 07.04.19	N.NISHIMATSU 07.04.19	M.ISHIDA 07.04.20	
DRAWING NO. EDC3-157004-01				PART NO. FH29B-**-S-0.2SHW(05)				
SCALE 5 : 1				CODE NO. CL580				
UNITS mm				HIROSE ELECTRIC CO., LTD				

Apr.1.2020 Copyright 2020 HIROSE ELECTRIC CO., LTD. All Rights Reserved.
 In case of consideration for using Automotive equipment / device which demand high reliability, kindly contact our sales window correspondents.

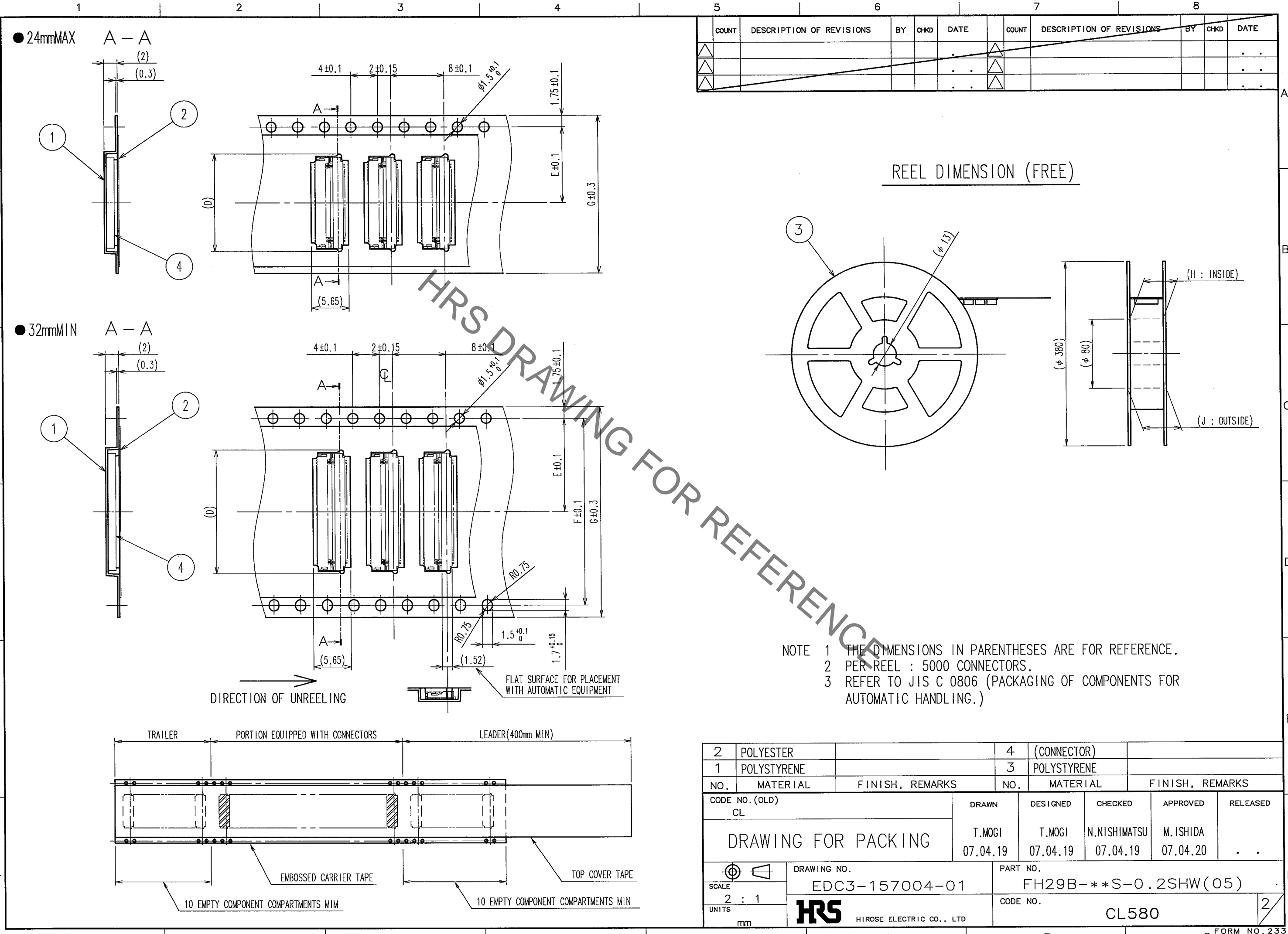

COUNT	DESCRIPTION OF REVISIONS	BY	CHKD	DATE	COUNT	DESCRIPTION OF REVISIONS	BY	CHKD	DATE

REEL DIMENSION (FREE)

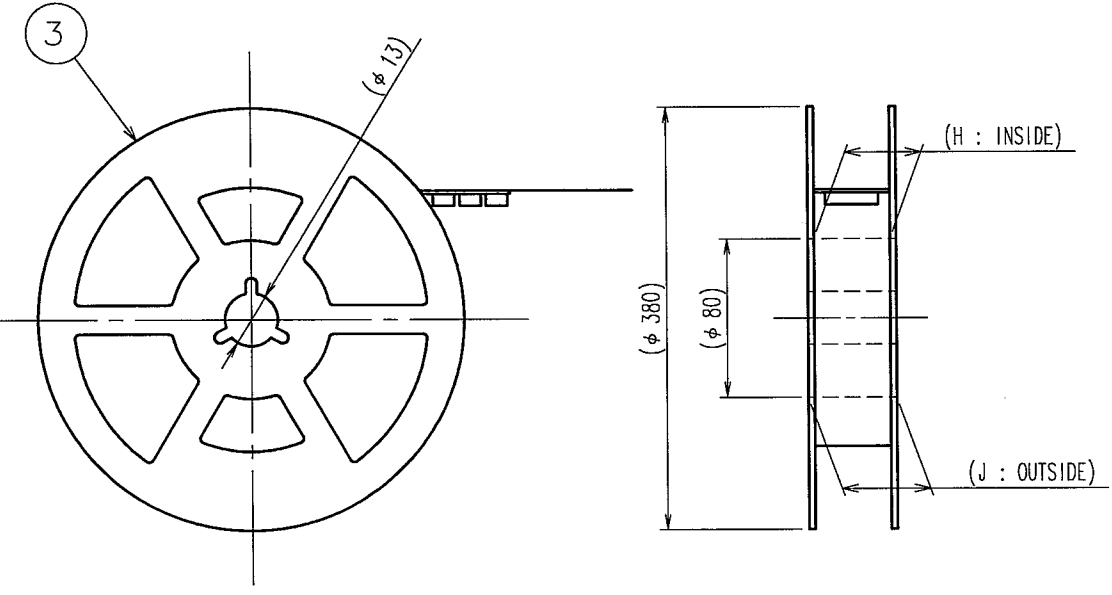

NOTE 1 THE DIMENSIONS IN PARENTHESES ARE FOR REFERENCE.
 2 PER REEL : 5000 CONNECTORS.
 3 REFER TO JIS C 0806 (PACKAGING OF COMPONENTS FOR AUTOMATIC HANDLING.)

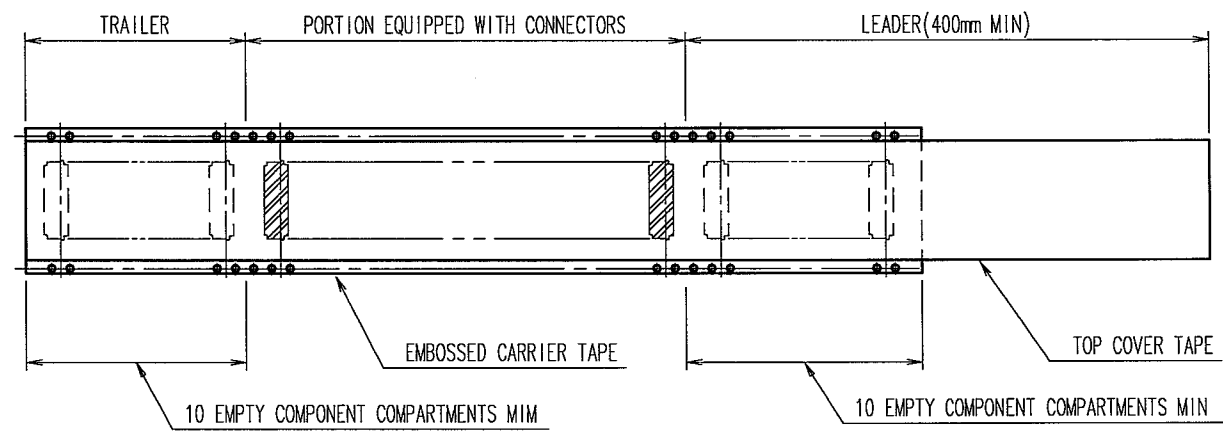

2	POLYESTER		4	(CONNECTOR)	
1	POLYSTYRENE		3	POLYSTYRENE	
NO.	MATERIAL	FINISH, REMARKS	NO.	MATERIAL	FINISH, REMARKS
CODE NO. (OLD) CL			DRAWN	DESIGNED	CHECKED
DRAWING FOR PACKING			T.MOGI 07.04.19	T.MOGI 07.04.19	N.NISHIMATSU 07.04.19
DRAWING NO. EDC3-157004-01			PART NO. FH29B-**S-0.2SHW(05)		
SCALE 2 : 1			CODE NO. CL580		
UNITS mm			2		

Apr.1.2020 Copyright 2020 HIROSE ELECTRIC CO., LTD. All Rights Reserved.
 Increase of consideration for using Automotive equipment / device which demand high reliability, kindly contact our sales window correspondents.

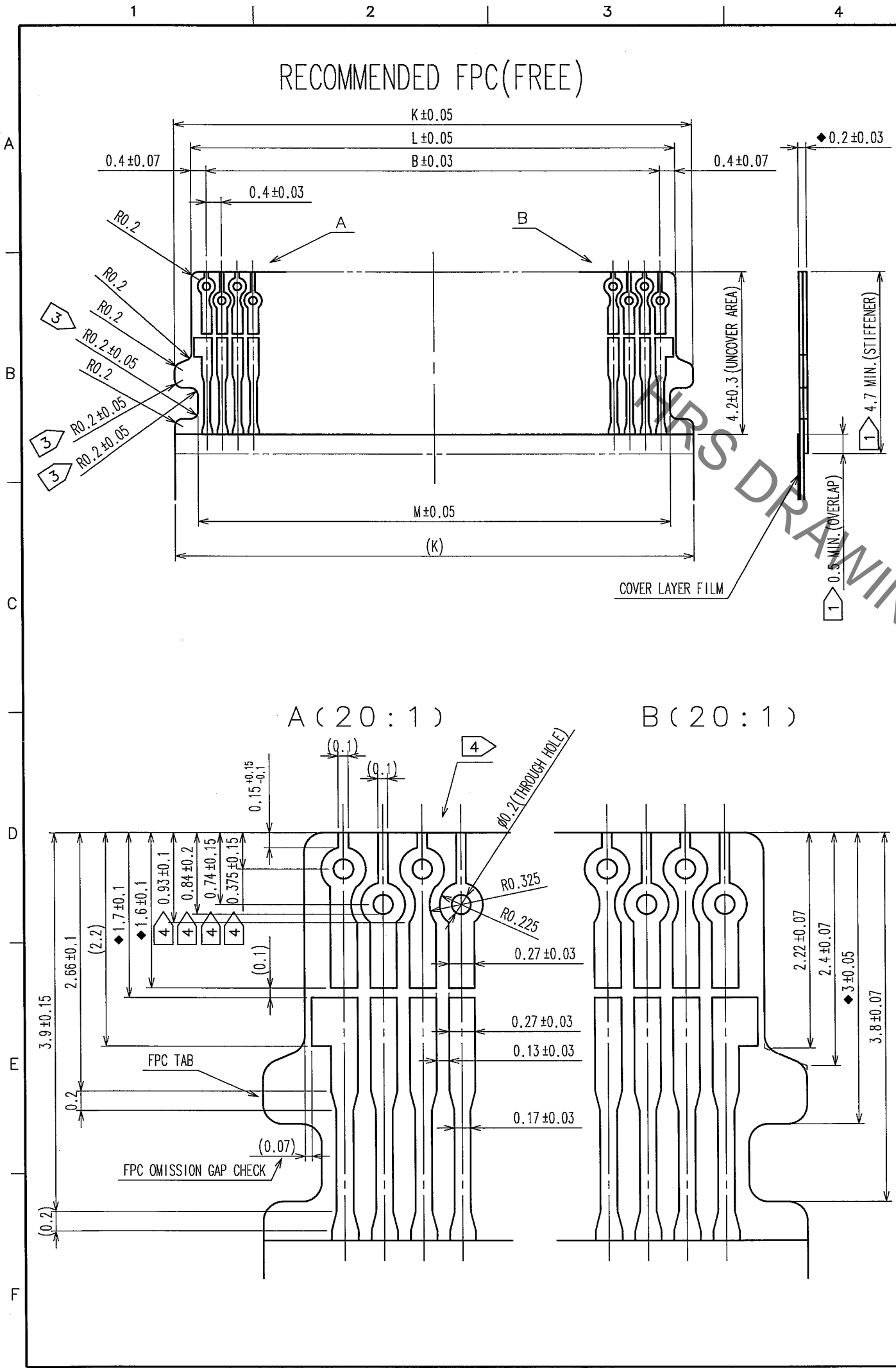

COUNT	DESCRIPTION OF REVISIONS	BY	CHKD	DATE	COUNT	DESCRIPTION OF REVISIONS	BY	CHKD	DATE
△					△				
△					△				

FPC CONSTRUCTION (Recommended Specifications)

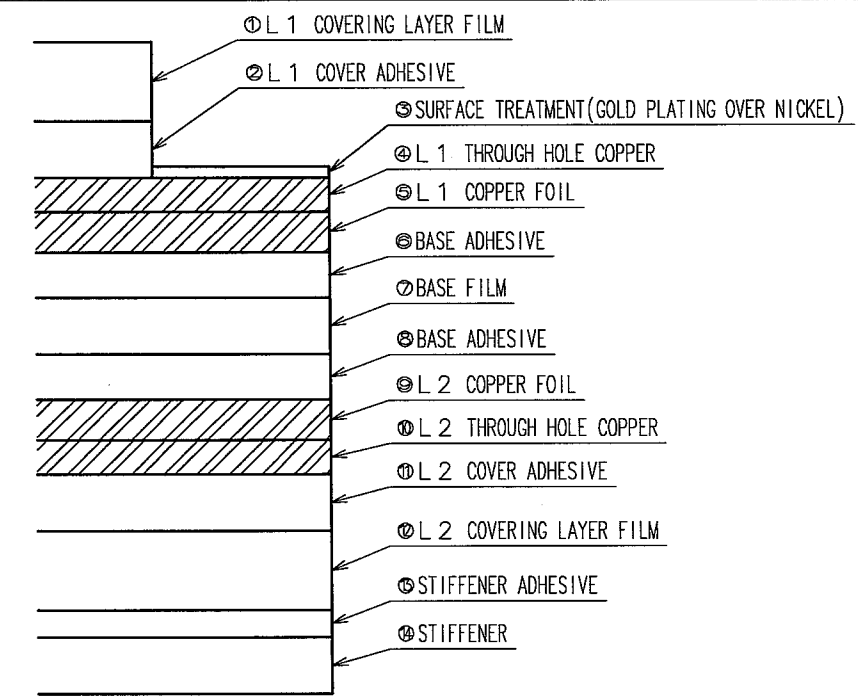

	THICKNESS (μm)		NOTES
	3 LAYERS CCL	2 LAYERS CCL	
①	25	12.5	
②	30	25	
③	3.5	3.5	GOLD PLATING OVER NICKEL
④	13	13	
⑤	18	12	
⑥	10	NO ADHESION MATERIAL	
⑦	25	25	
⑧	10	NO ADHESION MATERIAL	
⑨	18	12	
⑩	13	13	
⑪	25	20	
⑫	12.5	12.5	
⑬	30	30	POLYAMIDE + HEAT-HARDENED ADHESIVE
⑭	25	75	
TOTAL	203	216	TOTAL OF ③~⑭

- ① THE AMOUNT OF OVERLAP SHALL BE 0.5mm MIN. IN CASE THE LENGTH OF STIFFENER IS 4.7mm MAX DUE TO FPC DESIGN.
- ② FPC THICKNESS TO BE $t=0.20 \pm 0.03$ mm, REFERRING TO THE COMPONENT CONFIGURATION.
- ③ R TO BE 0.25mm MAX WHEN THE FPC MANUFACTURING TOLERANCE DOES NOT SATISFY ± 0.05 mm.
- ④ IN CASE THE DESIGNATED DIMENSIONS 0.93 ± 0.1, 0.84 ± 0.2, 0.74 ± 0.15, AND 0.375 ± 0.15 ARE UNMEASURABLE, PLEASE RESERVE THE HATCHING AREA OF MAGNIFIED DRAWING C.

NO.	MATERIAL	FINISH, REMARKS	NO.	MATERIAL	FINISH, REMARKS
CODE NO. (OLD) CL			DRAWN	DESIGNED	CHECKED
			T.MOGI	T.MOGI	N.NISHIMATSU
			07.04.19	07.04.19	07.04.19
			APPROVED	RELEASED	
			M.ISHIDA		
			07.04.20		
DRAWING NO.	EDC3-157004-01		PART NO.	FH29B-**S-0.2SHW(05)	
SCALE	FREE		CODE NO.	CL580	
UNITS	mm			3	

Apr.1.2020 Copyright 2020 HIROSE ELECTRIC CO., LTD. All Rights Reserved.
 Please of consideration for using Automotive equipment / device which demand high reliability, kindly contact our sales window correspondents.

This connector is small and thin and requires delicate and careful handling.
 Read through the instructions shown below and handle the connector properly.
 Each values indicating here are for reference and may differ from standard value.

【 INSTRUCTIONS FOR MOUNTING ON THE BOARD 】

- ◆Warp of Board
 Minimize warp of the board as much as possible.
 Lead co-planarity including reinforced metal fittings is 0.1 mm or less.
 Too much warp of the board may result in a soldering failure.
- ◆Load to Connector
 Do not apply a force of 0.5 N or more to the connector before mounting it on the board.
 Otherwise, the connector may be broken.
 Do not insert the FPC or operate the connector before mounting it.
- ◆Lord to Board
 · Splitting a large board into several pieces
 · Screwing the board
 Avoid the handling described above so that no force is exerted on the board during the assembly process.
 Otherwise, the connector may become defective.
- ◆Amount of Warp
 The warp of a 100-mm wide board should be 0.5 mm or less.
 The warp of board suffers stress on connector and the connector may become defective.

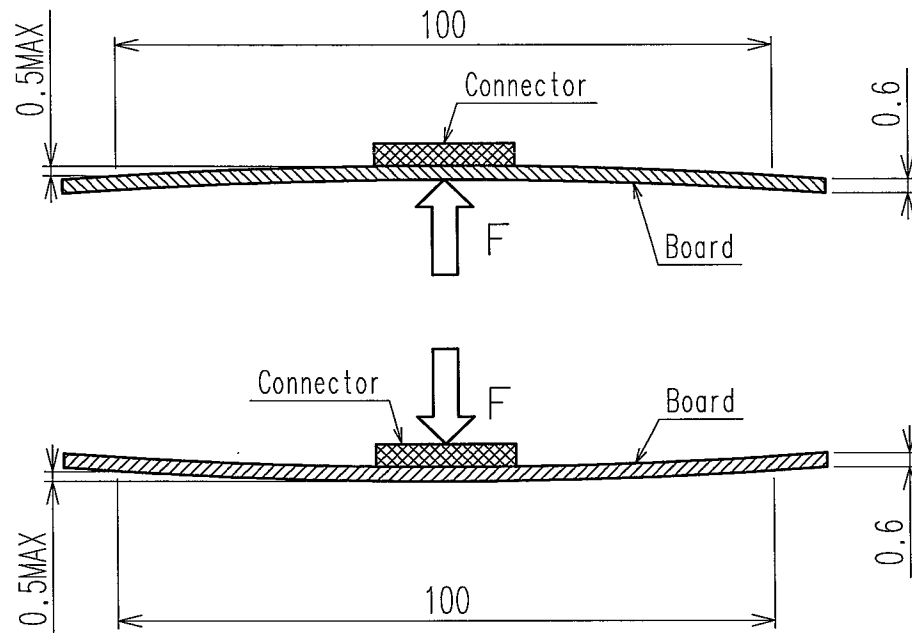

5				6				7				8			
COUNT	DESCRIPTION OF REVISIONS	BY	CHKD	DATE	COUNT	DESCRIPTION OF REVISIONS	BY	CHKD	DATE	COUNT	DESCRIPTION OF REVISIONS	BY	CHKD	DATE	
△					△					△					
△					△					△					
△					△					△					

【 INSTRUCTIONS ON INSERTING FPC AND CONNECTION 】

- ◆ Use of the Lock Lever
 1. Be very careful not to apply excessive force when releasing the lock lever in the initial position (with no FPC inserted).
 If you use your nail or finger as shown below, the terminals may be deformed.

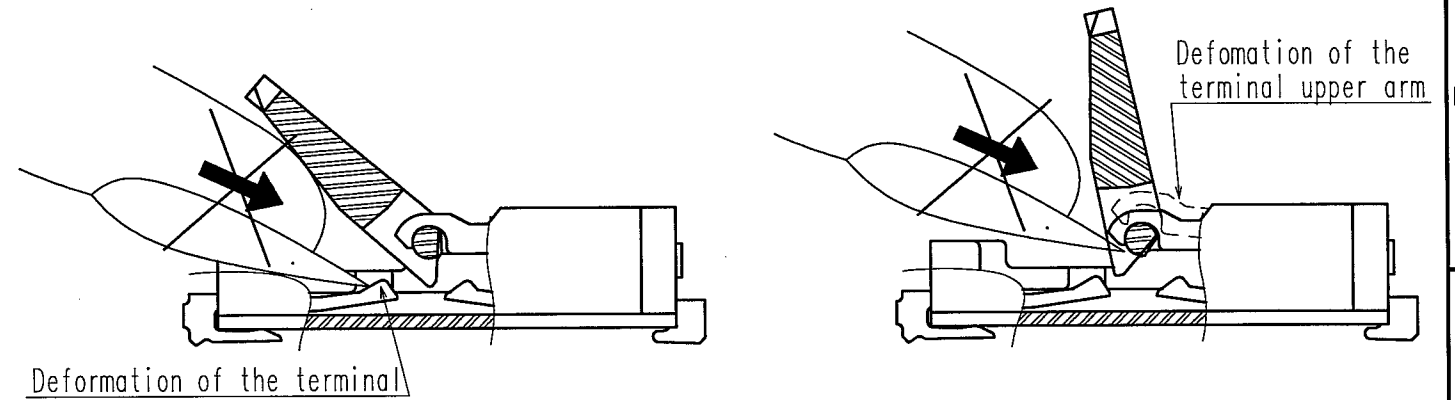

2. The lock lever rotates around the rotational axis as shown below.
 Rotate the lock lever.

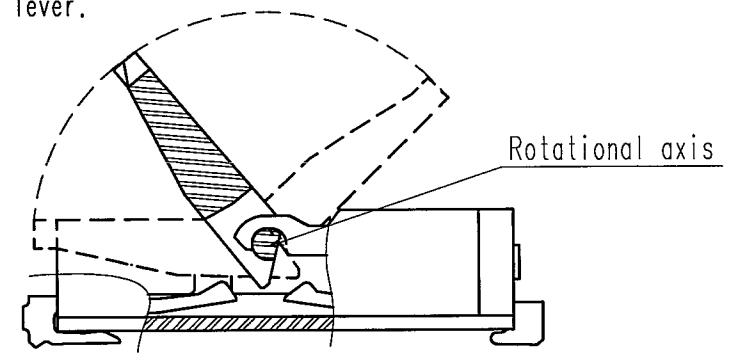

3. The lock lever will not open more than 135° .
 Do not apply any force backward beyond this point.
 Otherwise, the lock lever may come off or break.

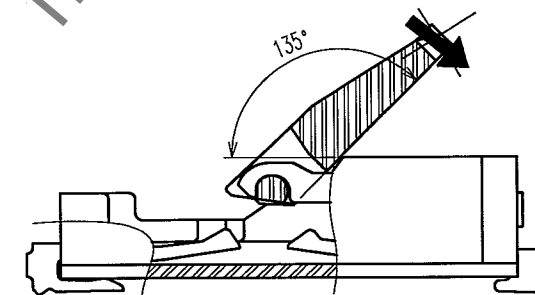

CODE NO. (OLD) CL	DRAWN T.MOGI 07.04.19	DESIGNED T.MOGI 07.04.19	CHECKED N.NISHIMATSU 07.04.19	APPROVED M.ISHIDA 07.04.20	RELEASED .
INSTRUCTION MANUAL			PART NO. FH29B-***S-0.2SHW(05)		
SCALE FREE	DRAWING NO. EDC3-157004-01		CODE NO. CL580		
UNITS mm	HRS HIROSE ELECTRIC CO., LTD		5		

Apr.1.2020 Copyright 2020 HIROSE ELECTRIC CO., LTD. All Rights Reserved.
 In case of consideration for using Automotive equipment / device which demand high reliability, kindly contact our sales window correspondents.

4. Move the lock lever at approximately the center.
 (It may break if operate the edge of the lock lever with FPC inserted.)
5. Do not pinch or pick the lock lever to lift it as shown below. Otherwise, it may break.
 (Do not carry out any operation other than rotating the lever as shown in 2 above.)

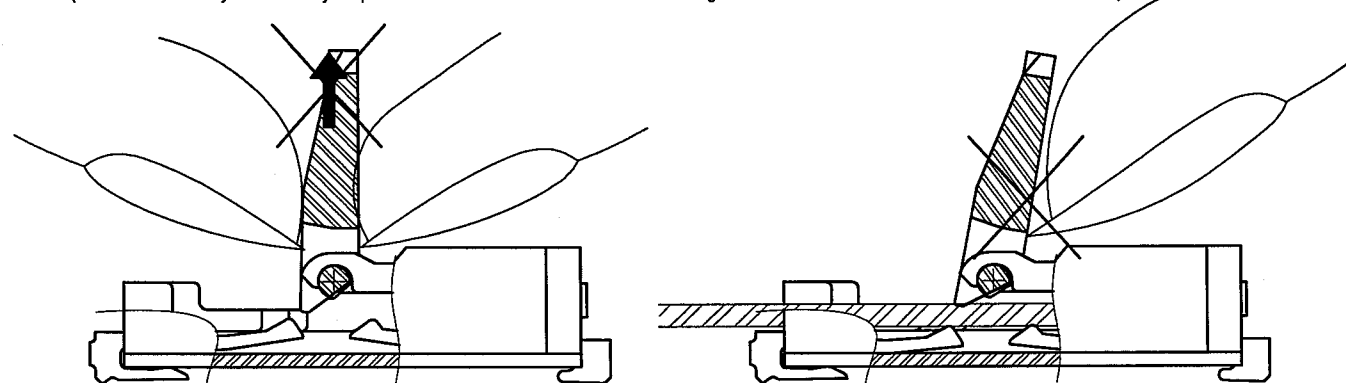

◆ Direction of Contacts
 This connector has contacts on the bottom. Thus, insert it with the exposed conductors face down.

- ◆ Inserting the FPC
1. Insert the FPC by about 10 degrees along the surface and at a right angle to the connector.
 Insert it properly to the very end.
 If the FPC is inserted at a slant (incorrectly), the conductors may short-circuit due to pitch shift or the edge of the FPC may catch in the terminals, resulting in deformation of the terminals.

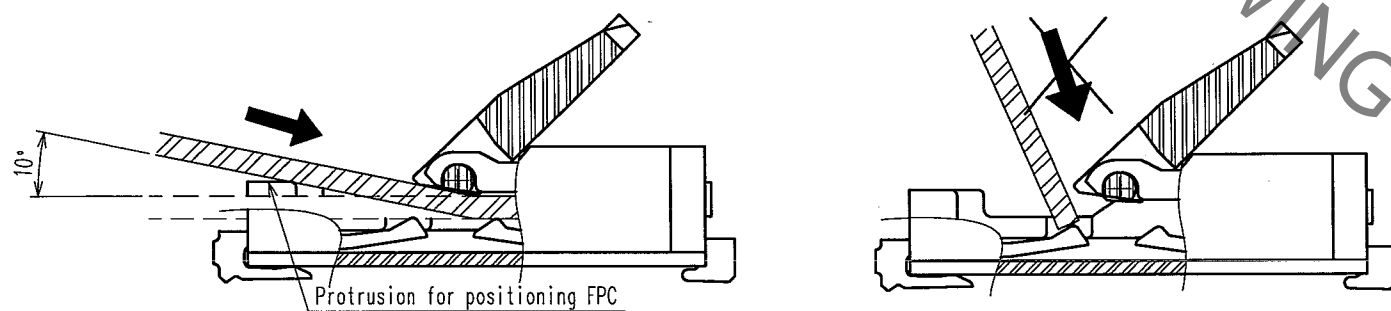

2. Do not insert the FPC diagonally from above.
 If the FPC is inserted at a slant (incorrectly) as shown below in the FPC insertion process, the FPC may bend and patterns may break or the FPC may not insert completely, resulting in improper conduction.

※ Keep a sufficient FPC insertion space in the stage of the layout in order to avoid incorrect FPC insertion.
 Besides, it is not difficult to insert FPC correctly all the way to the end.
 Design the proper layout of parts.

※ Make adjustments with the FPC manufacturer for FPC bending performance and wire breakage.

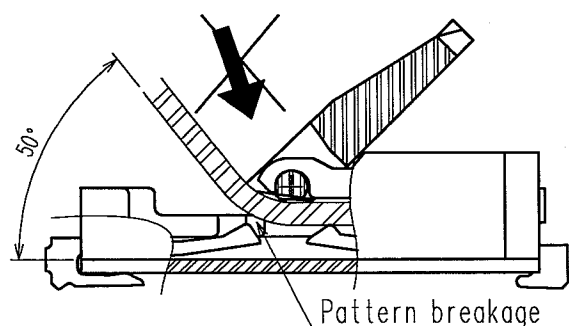

- ◆ Checking the Locking Condition
 In the locked condition, make sure that the lock lever is horizontal on the board surface.
 Do not apply excessive force to it near the 0° position of the lever.
 Otherwise, the terminals may be deformed. (Allowable force: 1 N or less)

5				6				7				8			
COUNT	DESCRIPTION OF REVISIONS	BY	CHKD	DATE	COUNT	DESCRIPTION OF REVISIONS	BY	CHKD	DATE	COUNT	DESCRIPTION OF REVISIONS	BY	CHKD	DATE	
△					△					△					
△					△					△					
△					△					△					

【 INSTRUCTIONS ON FPC LAYOUT AFTER CONNECTION 】

- ◆ Load to FPC
 Be very careful not to apply any force to the FPC after inserting it.
 Otherwise, the connector may become unlocked or the FPC may break.
 Fix the FPC, in particular, when loads are applied to it continuously.
 Design the FPC layout with care not to bend it sharply near the insertion opening.

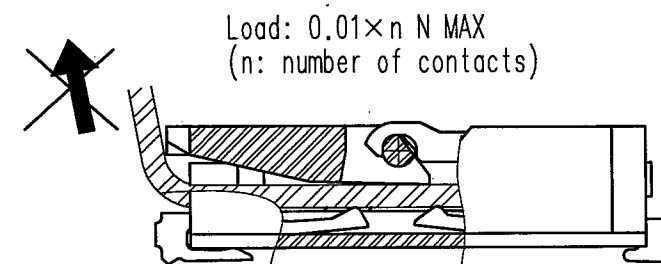

【 INSTRUCTIONS ON REMOVING FPC 】

- ◆ Release the lock lever at approximately the center.
 (It may break if operate the edge of the lock lever with FPC inserted.)
- ◆ Release the lock lever to remove the FPC.
 Remove the FPC by about 10 degrees along the surface.

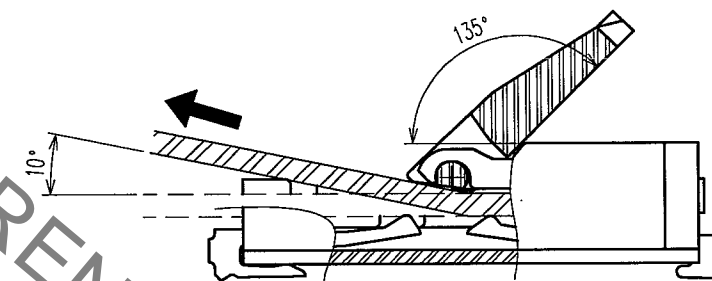

【 OTHER INSTRUCTIONS 】

- ◆ Instructions on Manual Soldering
 Follow the instructions shown below when soldering the connector manually during repair work, etc.
1. Do not perform reflow soldering or manual soldering with the FPC inserted into the connector.
 2. Do not heat the connector excessively. Be very careful not to let the soldering iron contact any parts other than connector leads. Otherwise, the connector may be deformed or melt.
 3. Do not use excessive solder (or flux).
 If excessive solder (or flux) is used on the terminals, solder or flux may adhere to the contacts or rotating parts of the lock lever, resulting in poor contact or a rotation failure of the lock lever.

CODE NO. (OLD) CL	DRAWN T.MOGI 07.04.19	DESIGNED T.MOGI 07.04.19	CHECKED N.NISHIMATSU 07.04.19	APPROVED M.ISHIDA 07.04.20	RELEASED .
INSTRUCTION MANUAL			PART NO. FH29B-**S-0.2SHW(05)		
SCALE FREE	DRAWING NO. EDC3-157004-01		CODE NO. CL580		
UNITS mm	HRS HIROSE ELECTRIC CO., LTD		6		