

Sep.1.2019 Copyright 2019 HIROSE ELECTRIC CO., LTD. All Rights Reserved.
In case of consideration for using Automotive equipment / device which demand high reliability, kindly contact our sales window correspondents.

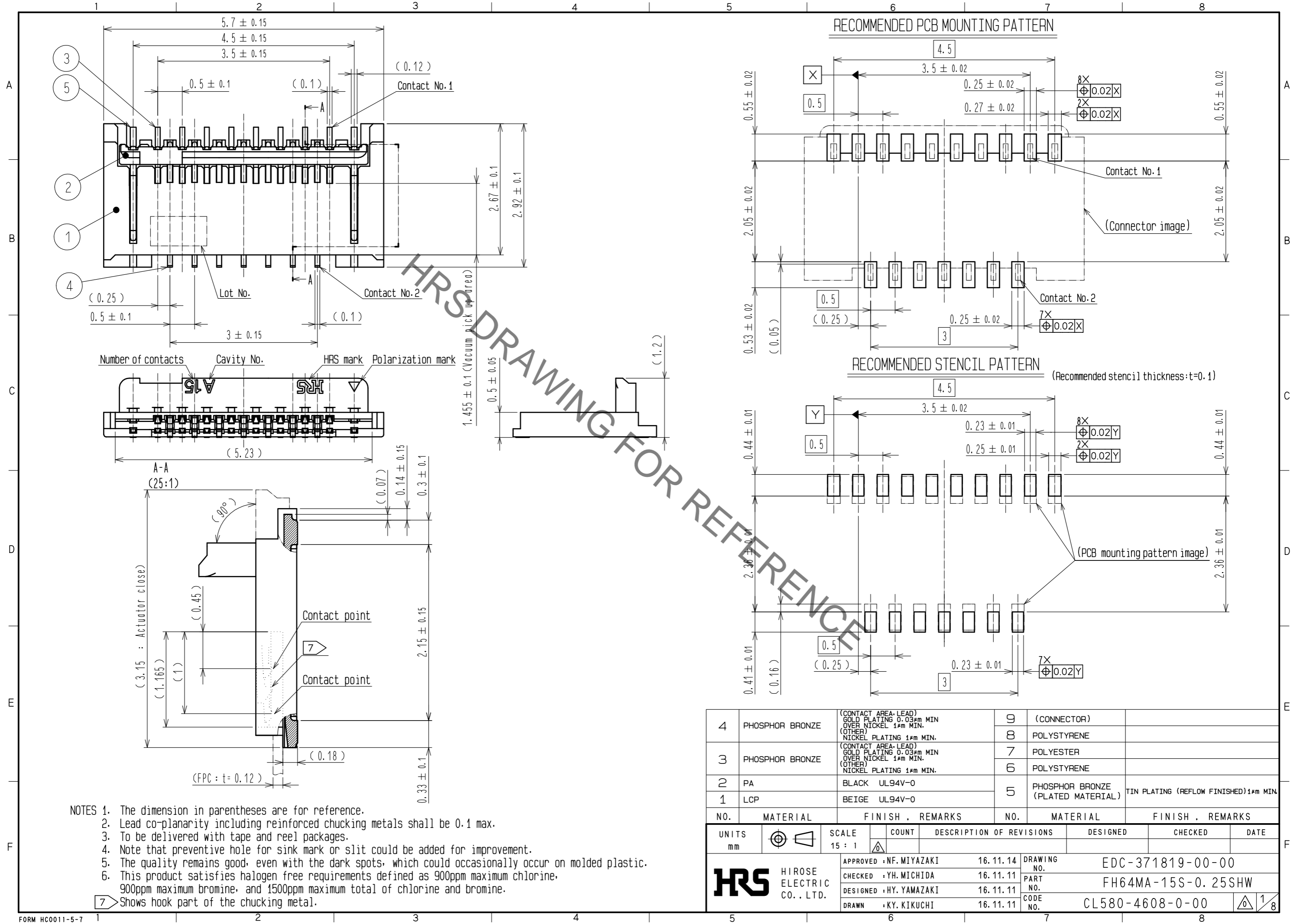

- NOTES
- The dimension in parentheses are for reference.
 - Lead co-planarity including reinforced chucking metals shall be 0.1 max.
 - To be delivered with tape and reel packages.
 - Note that preventive hole for sink mark or slit could be added for improvement.
 - The quality remains good, even with the dark spots, which could occasionally occur on molded plastic.
 - This product satisfies halogen free requirements defined as 900ppm maximum chlorine, 900ppm maximum bromine, and 1500ppm maximum total of chlorine and bromine.
 - Shows hook part of the chucking metal.

4	PHOSPHOR BRONZE	(CONTACT AREA LEAD) GOLD PLATING 0.03µm MIN OVER NICKEL 1µm MIN. (OTHER) NICKEL PLATING 1µm MIN.	9	(CONNECTOR)	
3	PHOSPHOR BRONZE	(CONTACT AREA LEAD) GOLD PLATING 0.03µm MIN OVER NICKEL 1µm MIN. (OTHER) NICKEL PLATING 1µm MIN.	8	POLYSTYRENE	
2	PA	BLACK UL94V-0	7	POLYESTER	
1	LCP	BEIGE UL94V-0	6	POLYSTYRENE	
			5	PHOSPHOR BRONZE (PLATED MATERIAL)	TIN PLATING (REFLOW FINISHED) 1µm MIN.
NO.	MATERIAL	FINISH . REMARKS	NO.	MATERIAL	FINISH . REMARKS
UNITS		SCALE	COUNT	DESCRIPTION OF REVISIONS	
mm		15 : 1		DESIGNED	CHECKED
HIROSE ELECTRIC CO., LTD.			APPROVED	DRAWING NO. EDC-371819-00-00	
			CHECKED	PART NO. FH64MA-15S-0.25SHW	
			DESIGNED	CODE NO. CL580-4608-0-00	
			DRAWN	1/8	

Sep.1.2019 Copyright 2019 HIROSE ELECTRIC CO., LTD. All Rights Reserved.
 In case of consideration for using Automotive equipment / device which demand high reliability, kindly contact our sales window correspondents.

EMBOSSED CARRIER TAPE DIMENSION (5:1)

Direction of unreeling →

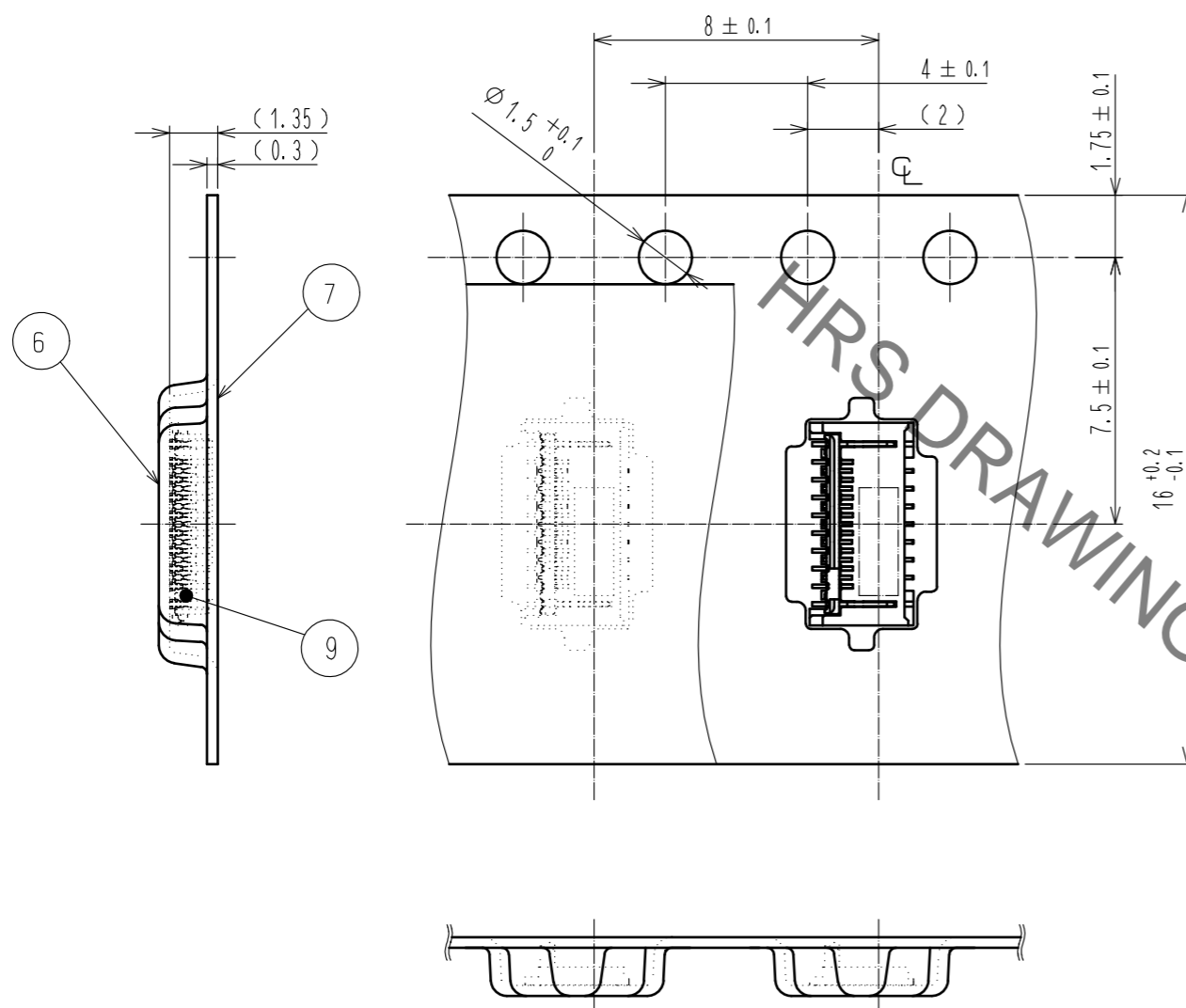

REEL DIMENSION (FREE)

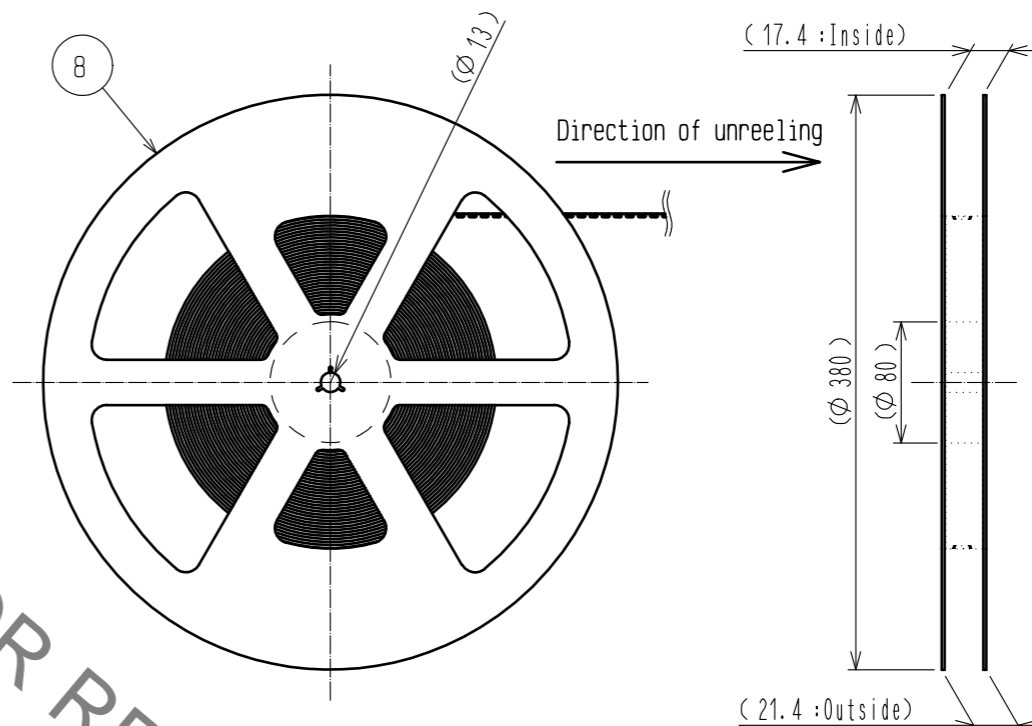

NOTES 12. Per reel : 5000 connectors.
 13. Refer to JIS C 0806 and IEC 60286-3
 (Packaging of components for automatic handling.)

LEADER, TRAILER DIMENSION (FREE)

Direction of unreeling →

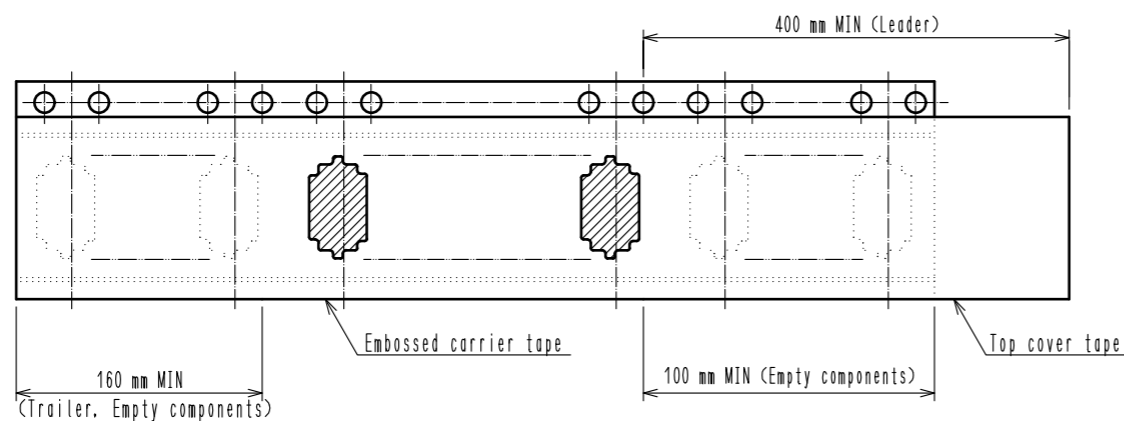

<PACKING SPECIFICATIONS>

HRS	DRAWING NO.	EDC-371819-00-00
	PART NO.	FH64MA-15S-0.25SHW
	CODE NO.	CL580-4608-0-00
		3/8

Sep.1.2019 Copyright 2019 HIROSE ELECTRIC CO., LTD. All Rights Reserved.
In case of consideration for using Automotive equipment / device which demand high reliability, kindly contact our sales window correspondents.

This connector features small and thin, requiring delicate and careful handling.
To prevent connector/FPC breakage and contact failure (mating failure, FPC pattern breakage, etc),
read through the instructions shown below and handle the connector properly.

[Connector Part Nomenclature]

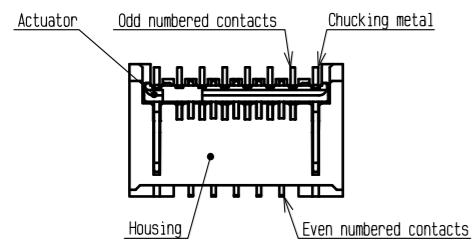

Top view

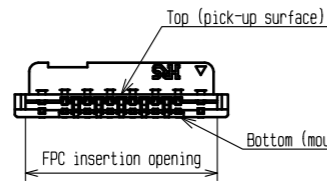

Front view

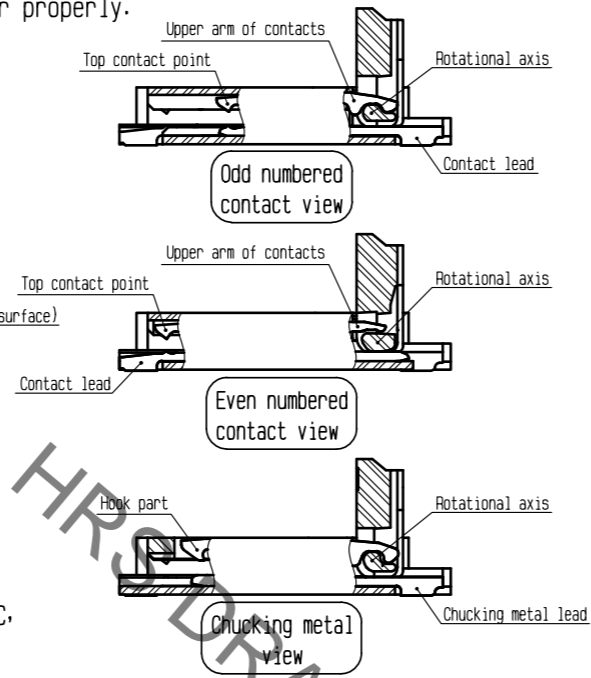

[Operation and Precautions]

1. Initial condition

Actuator does not have to be operated before inserting FPC,
as the connector is delivered with the actuator opened.

[Caution]

- Do not close the actuator before inserting FPC.
Closing the actuator without FPC could make the contact gap smaller, which could increase the FPC insertion force. (Example1)
- Do not insert FPC or operate actuator before mounting. (Example1)

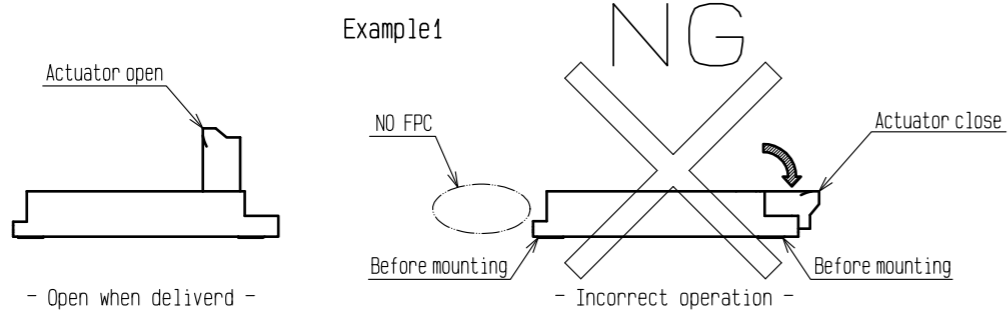

2. How to insert FPC

Insert the FPC into the connector opening horizontally to the PCB plane.
Insert it properly to the very end. (Example2)

[Caution]

- Do not insert the FPC with the actuator closed. (Example3)
- Do not twist the FPC to up and down, right and left or an angle. (Example4)

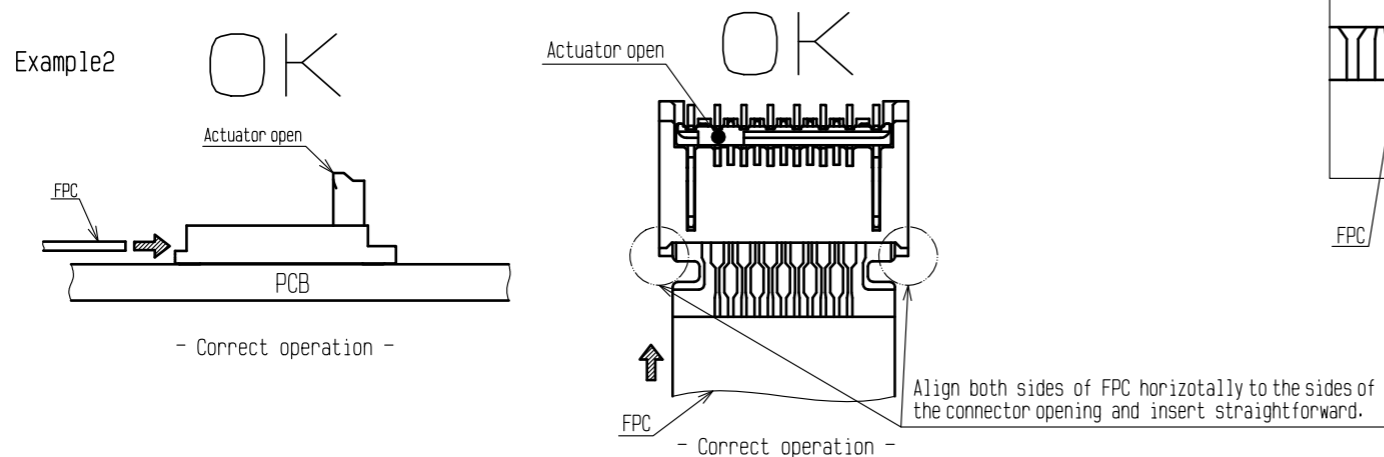

3. FPC insertion check

Make sure that the FPC tabs are located in proper position as shown in the figure below after FPC insertion. (Example5)

[Caution]

- Do not insert the FPC at an angle and/or stop it before insertion is completed. (Example6)(Example7)

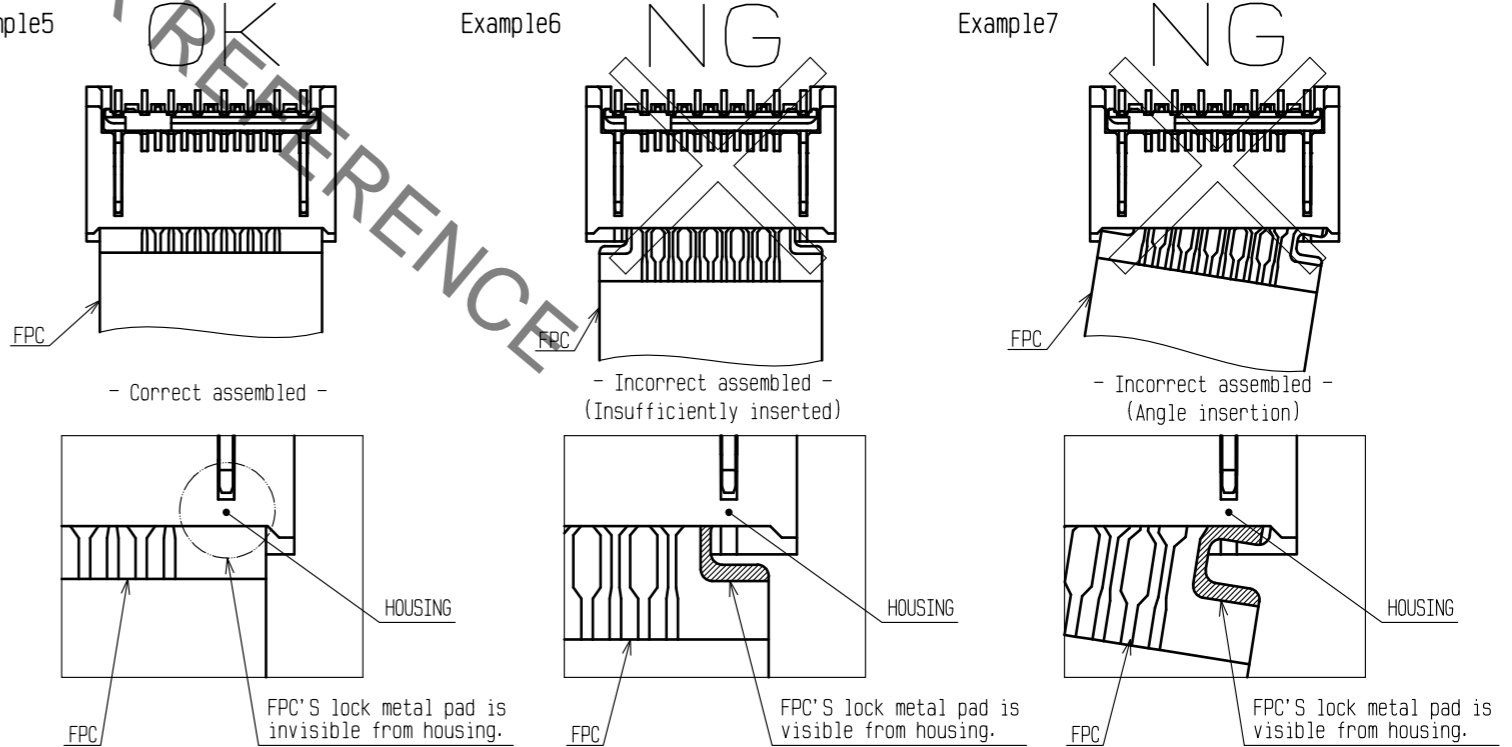

Example3

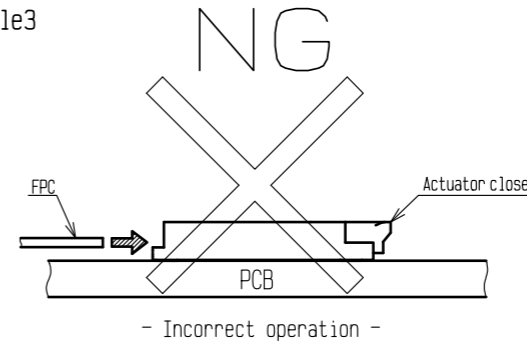

Example4

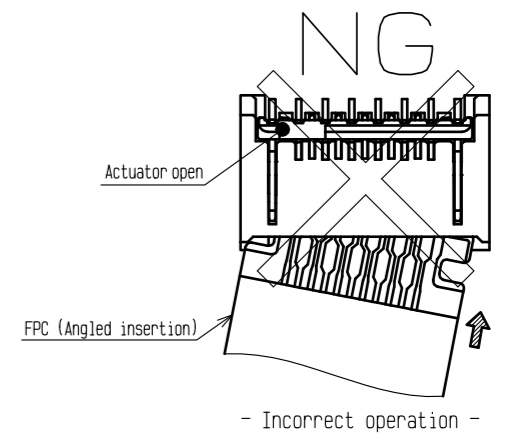
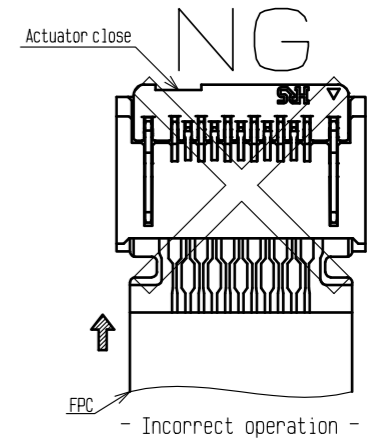
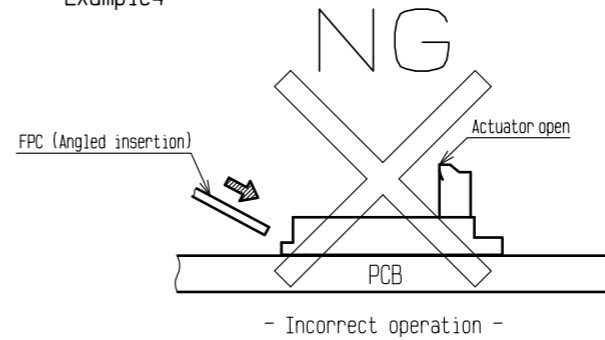

<INSTRUCTION MANUAL (1)>

HRS	DRAWING NO.	EDC-371819-00-00
	PART NO.	FH64MA-15S-0.25SHW
	CODE NO.	CL580-4608-0-00
		4/8

Sep.1.2019 Copyright 2019 HIROSE ELECTRIC CO., LTD. All Rights Reserved.
In case of consideration for using Automotive equipment / device which demand high reliability, kindly contact our sales window correspondents.

4. How to lock

The actuator rotates around the rotational axis as shown below.
Apply load to rotate the actuator by 90 degree after inserting the FPC. (Example8)

[Caution]

- To close the actuator, operate at the center of the actuator. (Example9)
- To close the actuator, do not operate the actuator at one end only. (Example10)
- Do not rotate the actuator to the counter direction. (Example11)
- Do not push out the actuator horizontally. (Example12)
- Do not push out the actuator vertically. (Example13)
- Do not operate the actuator while the upper contact arm is pressed down. (Example14)
- Do not pick the actuator to lift. (Example15)
- Operate the actuator by hand without using sharp tool such as Tweezers. (Example16)
- Do not apply excess force to the housing during the operation. (Example17)

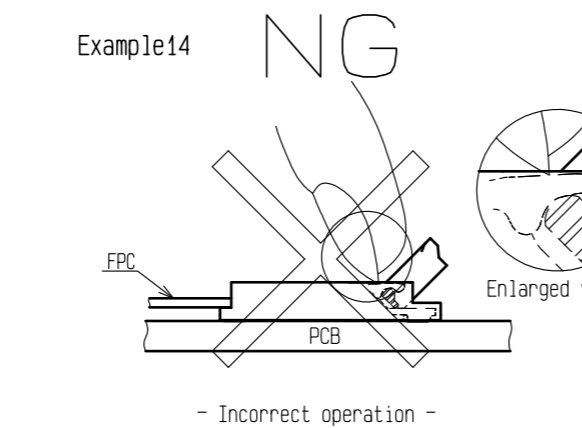
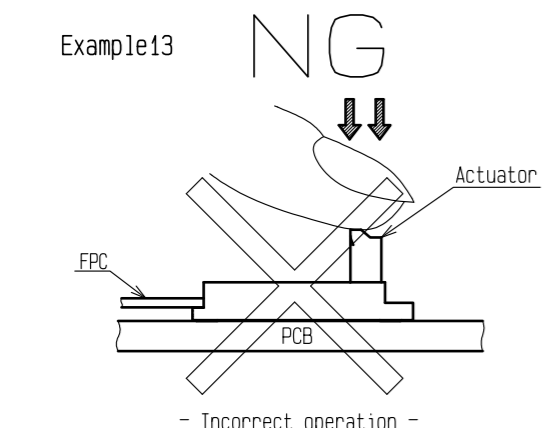
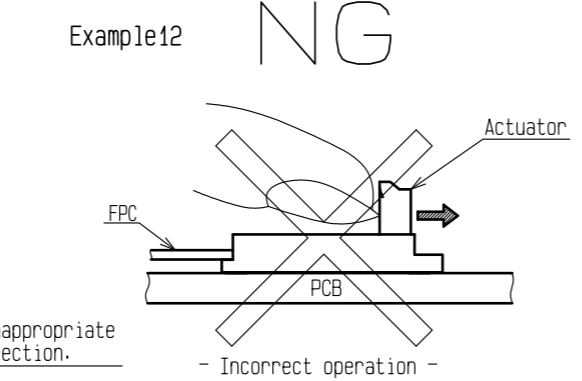
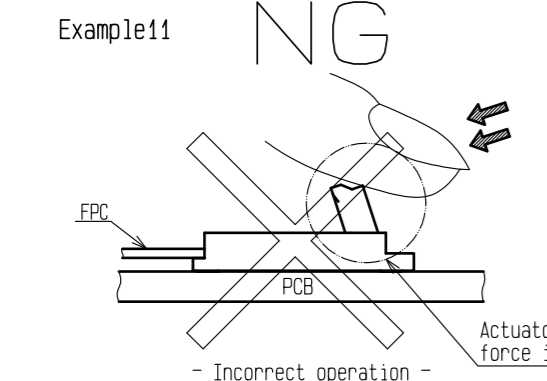
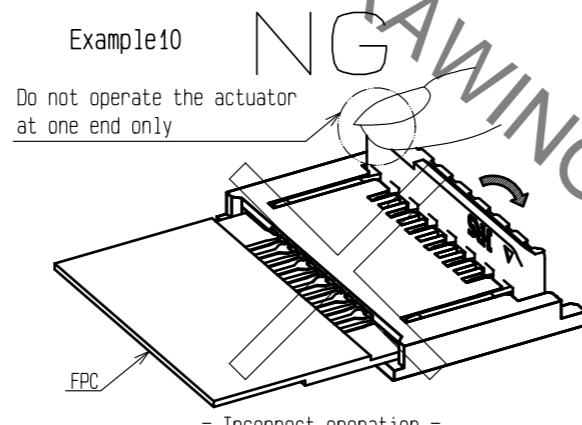
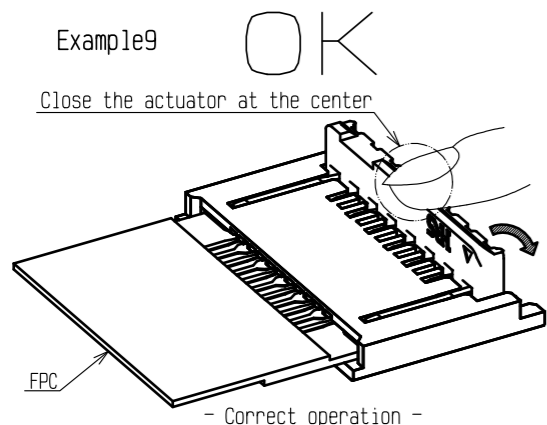
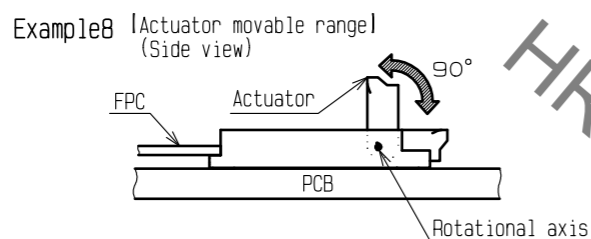

Example15

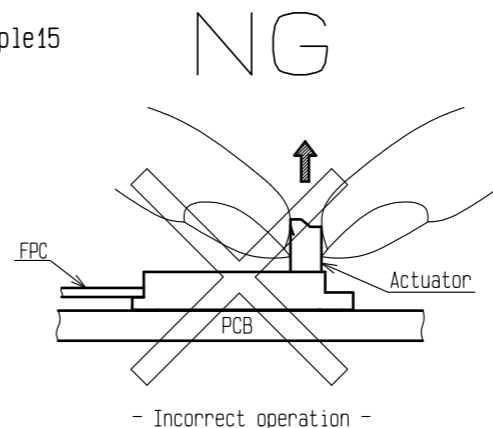

Example16

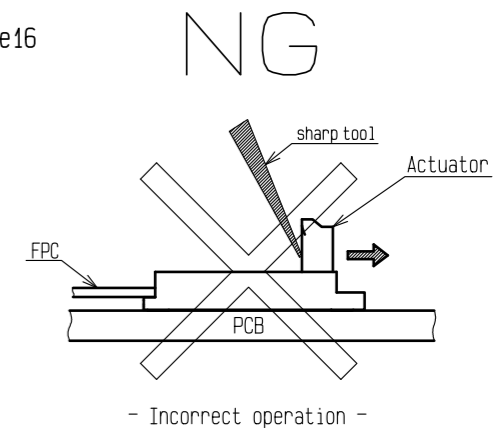

Example17

Do not apply excess force to the housing during the operation.

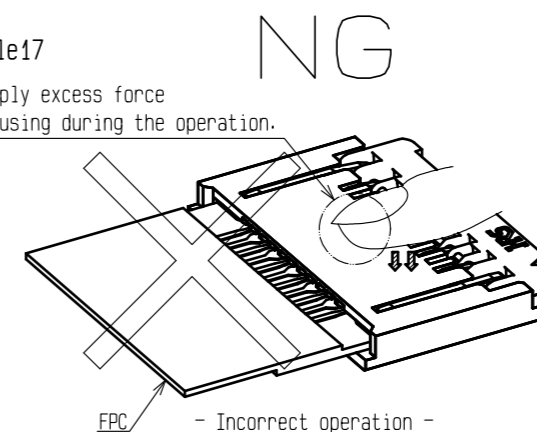

5. Mating confirmation of the FPC

Visually confirm the FPC positioning after closing the actuator. (Example18)

[Caution]

-Do not insert the FPC at an angle and/or stop it before insertion is completed. (Example19)(Example20)

Example18

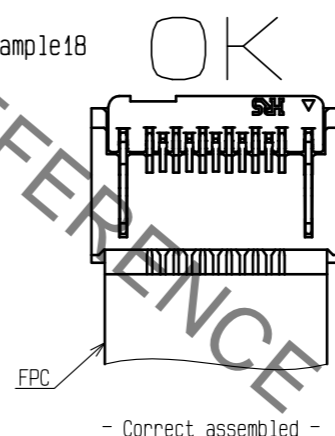

Example19

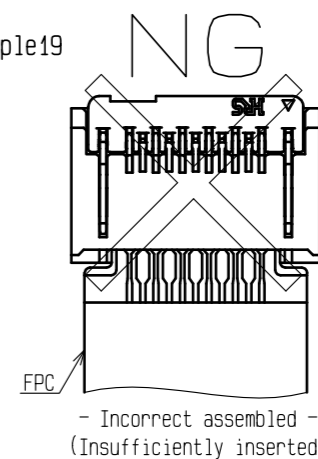

Example20

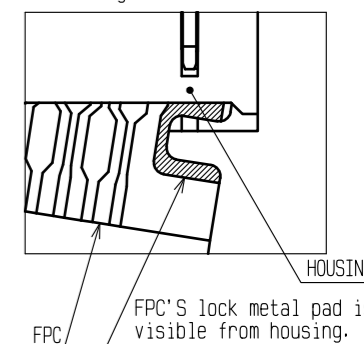
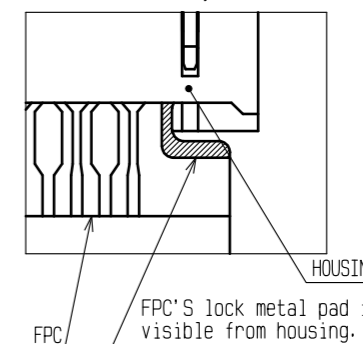
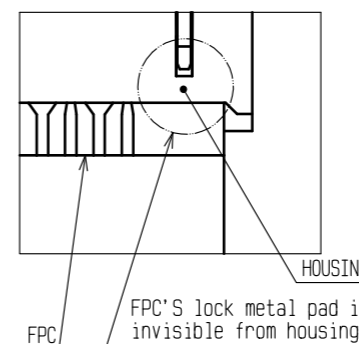
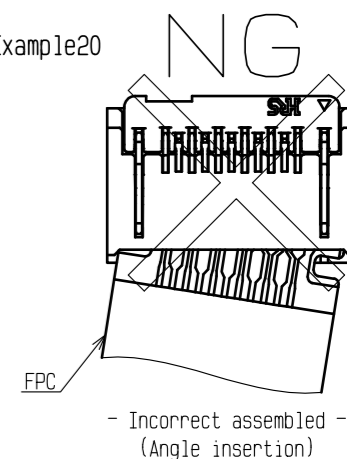

< INSTRUCTION MANUAL (2) >

HRS	DRAWING NO.	EDC-371819-00-00
	PART NO.	FH64MA-15S-0.25SHW
	CODE NO.	CL580-4608-0-00
		5/8

Sep.1.2019 Copyright 2019 HIROSE ELECTRIC CO., LTD. All Rights Reserved.
In case of consideration for using Automotive equipment / device which demand high reliability, kindly contact our sales window correspondents.

6. How to unlock

Slowly flip up the actuator to release the lock. (Example21)

[Caution]

- To open the actuator, operate at the center of the actuator. (Example22)
- To open the actuator, do not operate the actuator at one end only. (Example23)
- The actuator is opened up to the movable limit, 90 degree. (Example24)
- Do not open the actuator beyond the specified degree or apply excess force to the actuator.
- Open the actuator right above.
- Do not attempt to open further or to open it by applying horizontal force as this may cause its damage. (Example25)
- Do not pick the actuator to lift. (Example26)
- Operate the actuator by hand without using sharp tool such as Tweezers. (Example27)
- Do not apply excess force to the housing during the operation. (Example28)
- Please note that the connector is back flip style connector, and the opening for FPC insertion and the actuator face the opposite direction.
- Do not try to lift the actuator at the FPC insertion opening side. (Example29)

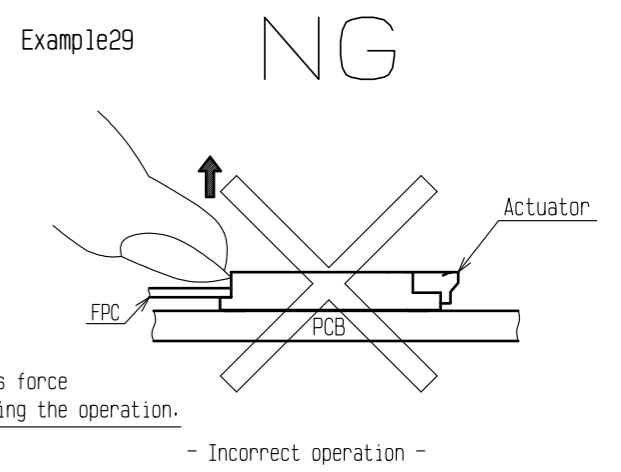
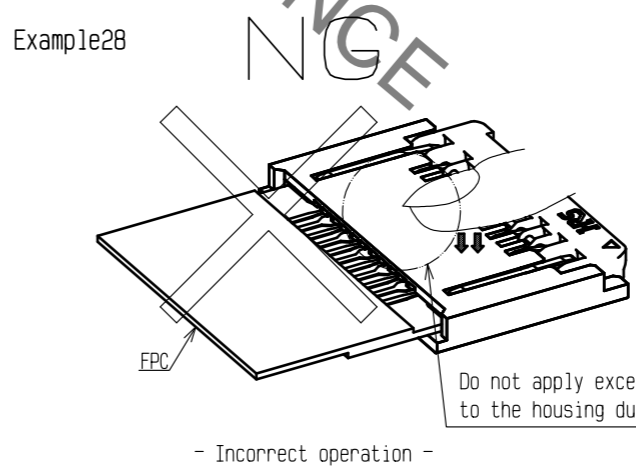
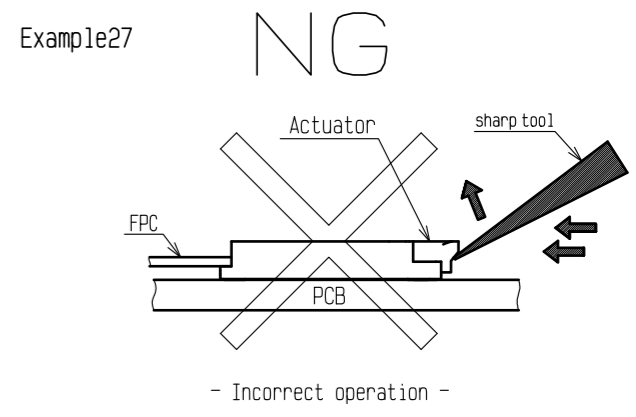
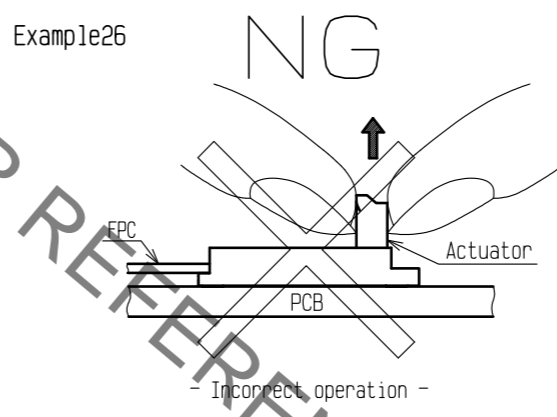
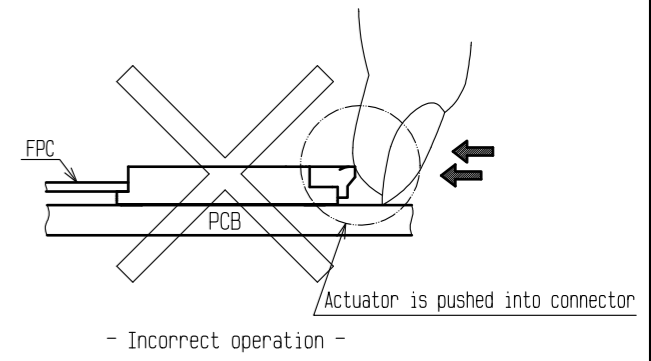
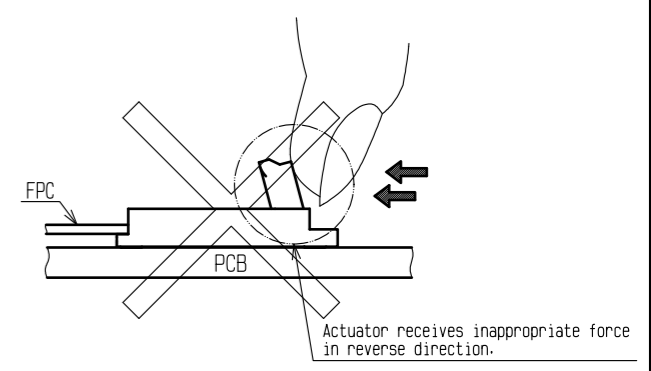
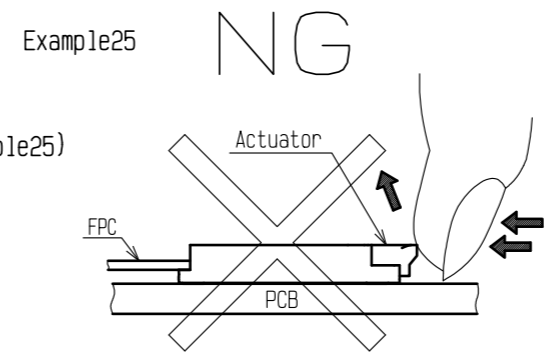
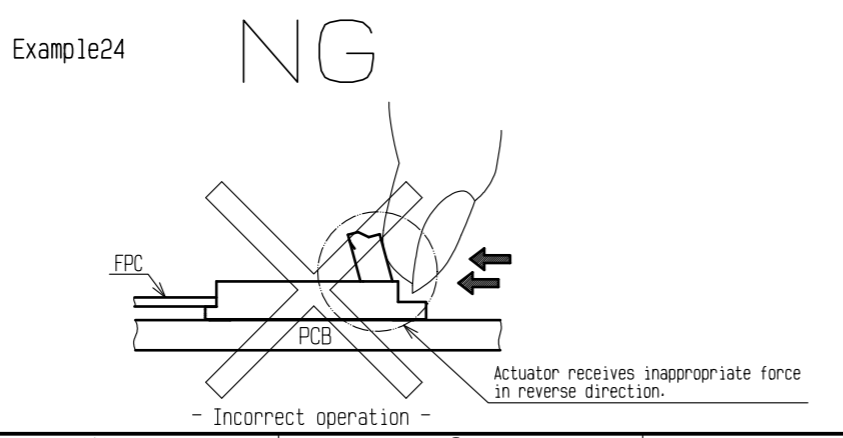
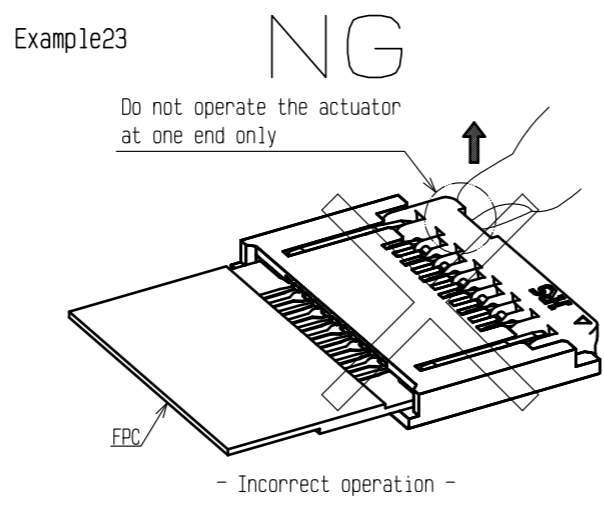
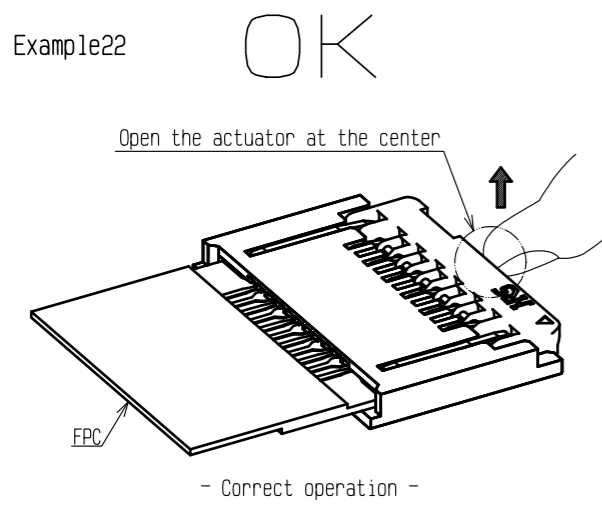
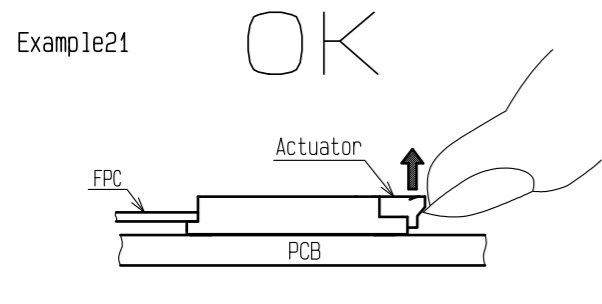

<INSTRUCTION MANUAL (3)>

HRS	DRAWING NO.	EDC-371819-00-00
	PART NO.	FH64MA-15S-0.25SHW
	CODE NO.	CL580-4608-0-00
		6/8

Sep.1.2019 Copyright 2019 HIROSE ELECTRIC CO., LTD. All Rights Reserved.
 In case of consideration for using Automotive equipment / device which demand high reliability, kindly contact our sales window correspondents.

7. How to remove FPC

After rotating the actuator to the fully opened position carefully withdraw the FPC pulling out horizontally. (Example30)

[Caution]

- For FPC removal, do not pull out the FPC upward or angled direction. (Example31)
- Do not attempt to pull the FPC without unlocking the actuator (Example32).

[Precautions for component layout]

Depending on a FPC rounding, a load is applied to the connector, and a contact failure may occur. To prevent a failure, take the following notes into a consideration during mechanism design.

[Caution]

- Avoid applying forces to FPC in vertical or horizontal directions. (Example33)(Example35)
- In addition, avoid pulling up and down on the FPC.
- When fixing FPC after FPC cabling, avoid pulling FPC, and route the wire FPC with slack. In this regard, the stiffener is parallel to the PCB. (Example34)
- During FPC wiring, ensure that stress is not applied directly to the connector. Do not bend the FPC excessively near the connector during use, or it may cause contact failure or FPC breakage. Stabilizing the FPC is recommended. (Example35)
- Do not mount other components touching to the FPC underneath the FPC stiffener. (Example36)
- Make adjustments with the FPC manufacturer for FPC bending performance and wire breakage.
- Keep a sufficient FPC insertion space in the stage of the layout in order to avoid incorrect FPC insertion. Appropriate FPC length and component layout are recommended for assembly ease. Too short FPC length makes assembly difficult.
- Keep spaces for the actuator movement and its operation for PCB design and component layout.

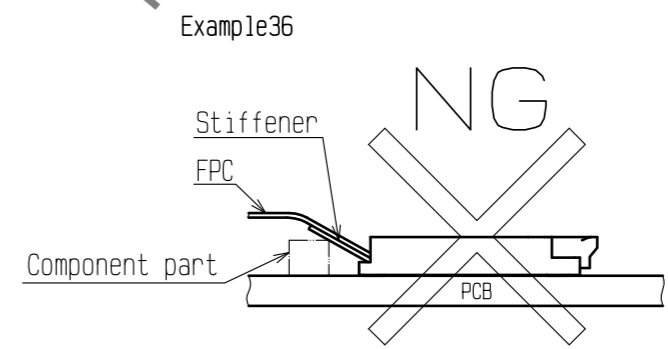
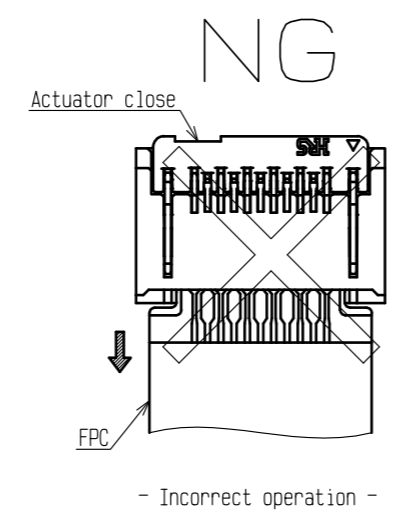
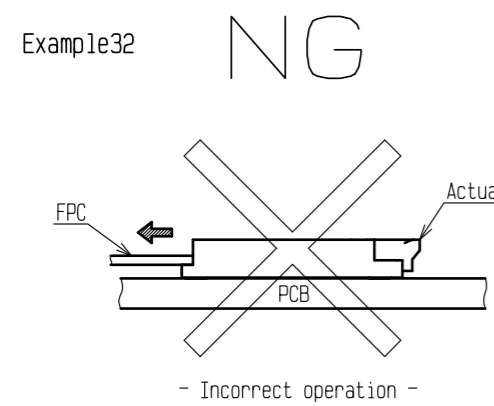
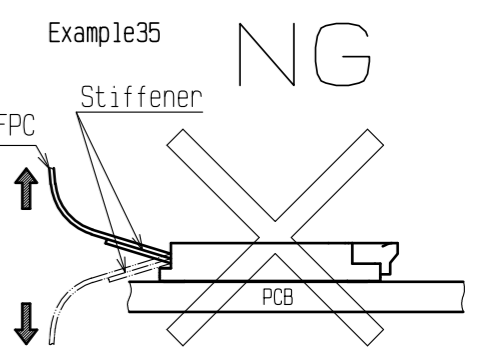
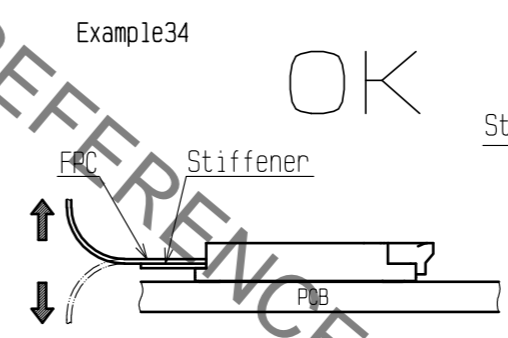
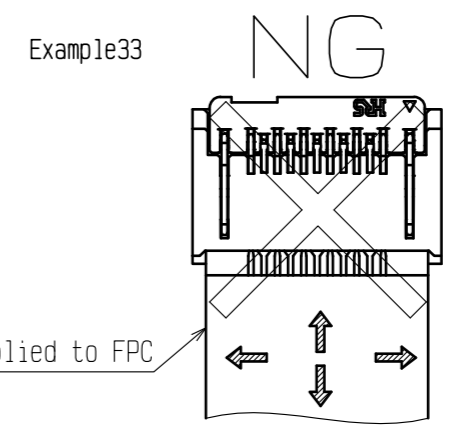
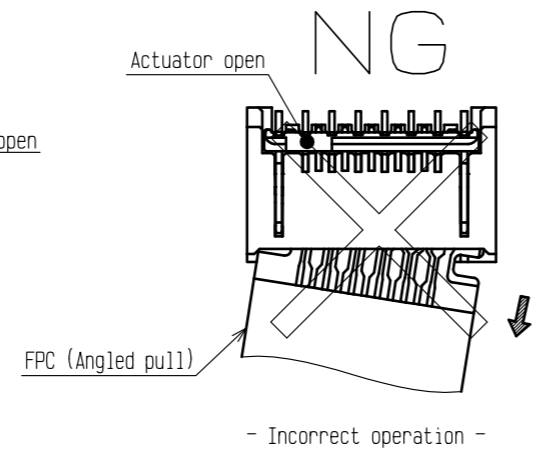
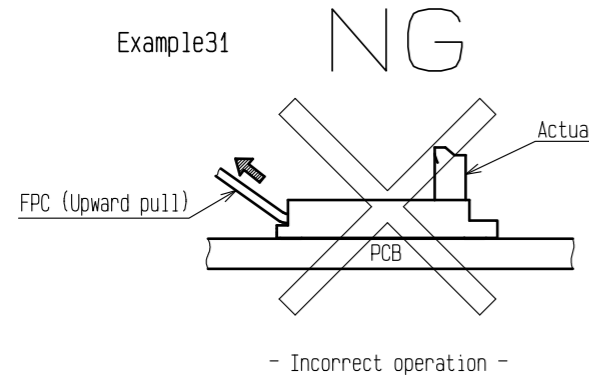
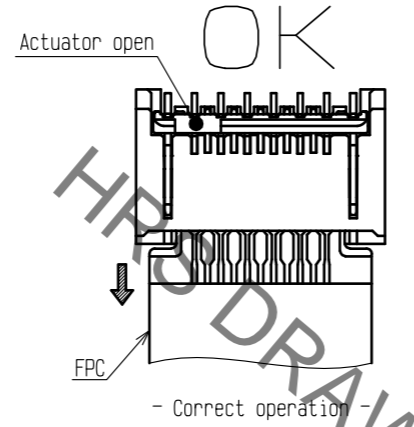
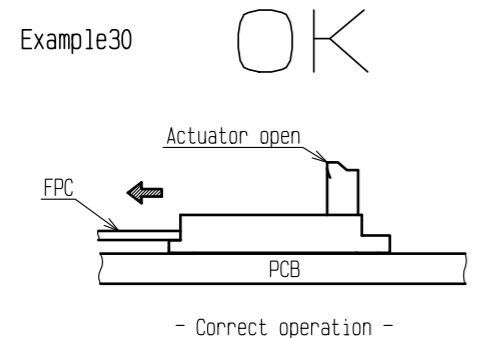

<INSTRUCTION MANUAL (4)>

HRS	DRAWING NO.	EDC-371819-00-00
	PART NO.	FH64MA-15S-0.25SHW
	CODE NO.	CL580-4608-0-00
		7/8

Sep.1.2019 Copyright 2019 HIROSE ELECTRIC CO., LTD. All Rights Reserved.
In case of consideration for using Automotive equipment / device which demand high reliability, kindly contact our sales window correspondents.

[Instructions for mounting on the PCB]

Follow the instructions shown below when mounting on the PCB.

[Caution]

- Refer to recommended layouts on the page 1 for PCB and stencil pattern.
- Shorter pattern width than the recommended PCB dimension, could cause solder wicking and/or flux penetration.
- Larger pattern than the recommended stencil dimension, could cause solder wicking and/or flux penetration.
- Clearance underneath the contact and the housing is very small.
In case solder resist and/or silk screening are applied on PCB underneath the connector, verify the thickness, or it could push up the connector bottom and may cause soldering defect and/or insufficient fillet formation.
- Apply reflow temperature profile within the specified conditions.
In individual applications, the actual temperature may vary, depending on solder paste type, volume/thickness and PCB size/thickness. Consult your solder paste and equipment manufacturer for specific recommendations.
- Prevent warpage of PCB, where possible, since it can cause soldering failure even with 0.1 mm max coplanarity.
- When mounting on the flexible board, please make sure to put a stiffener on the backside of the flexible board.
We recommend a glass epoxy material with the thickness of 0.3 mm min.
- Do not add 0.5 N or greater external force when unroll or pick and place the connector etc, or it may get broken.

[Instructions for PCB handling after mounting the connector]

Follow the instructions shown below when mounting on the PCB.

[Caution]

- Splitting a large PCB into several pieces
 - Screwing the PCB
- Avoid the handling described above so that no force is exerted on the PCB during the assembly process. Otherwise, the connector may become defective.
- The warp of a 100 mm wide PCB should be 0.5 mm or less.
The warp of PCB suffers stress on connector and the connector may become defective. (Example 37)

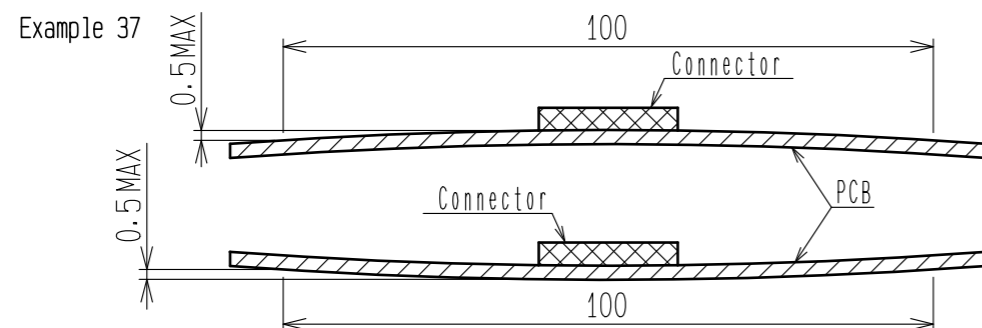

[Instructions on manual soldering]

Follow the instructions shown below when soldering the connector manually during repair work, etc.

[Caution]

- Do not perform manual soldering with the FPC inserted into the connector.
 - Do not heat the connector excessively. Be very careful not to let the soldering iron contact any parts other than connector leads. Otherwise, the connector may be deformed or melt.
 - Do not supply excessive solder (or flux).
- If excessive solder (or flux) is supplied on the terminals or chucking metals, solder or flux may adhere to the contacts or rotating parts of the actuator, resulting in poor contact or a rotation failure of the actuator. Supplying excessive solder to the chucking metals may hinder actuator rotation, resulting in breakage of the connector.

<INSTRUCTION MANUAL (5)>

HRS	DRAWING NO.	EDC-371819-00-00
	PART NO.	FH64MA-15S-0.25SHW
	CODE NO.	CL580-4608-0-00

8/8