

Mar.1.2020 Copyright 2020 HIROSE ELECTRIC CO., LTD. All Rights Reserved.
 In case of consideration for using Automotive equipment / device which demand high reliability, kindly contact our sales window correspondents.

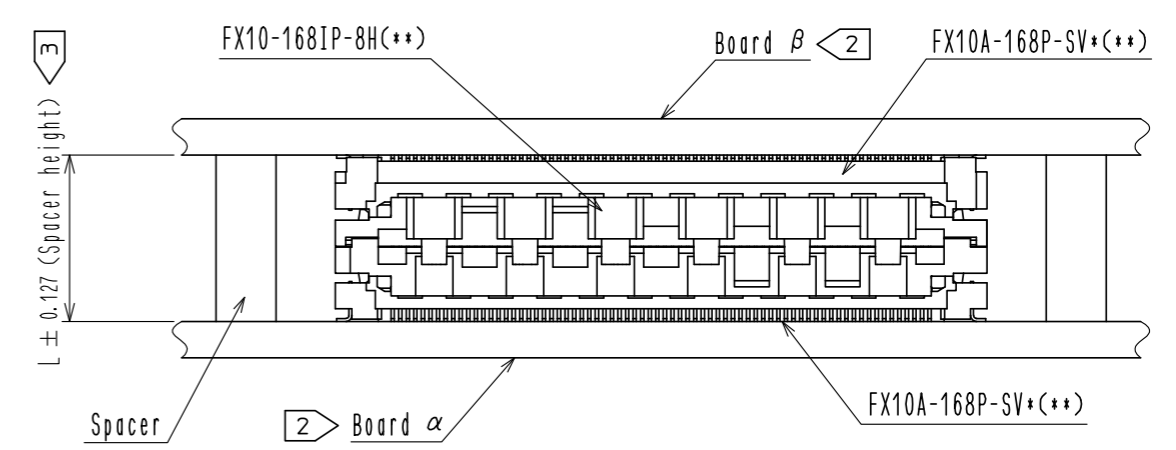
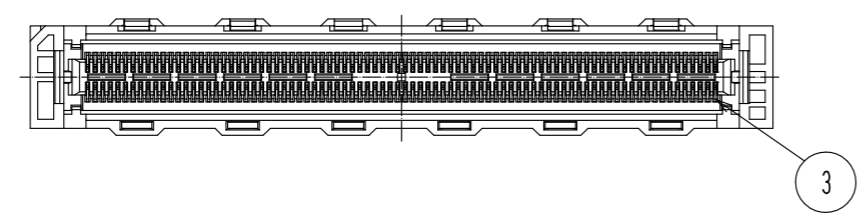
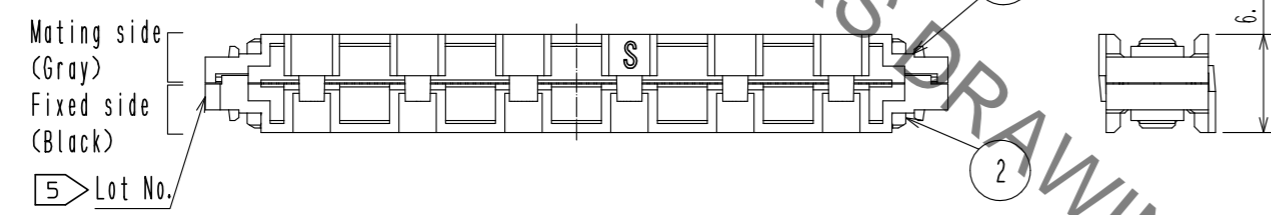
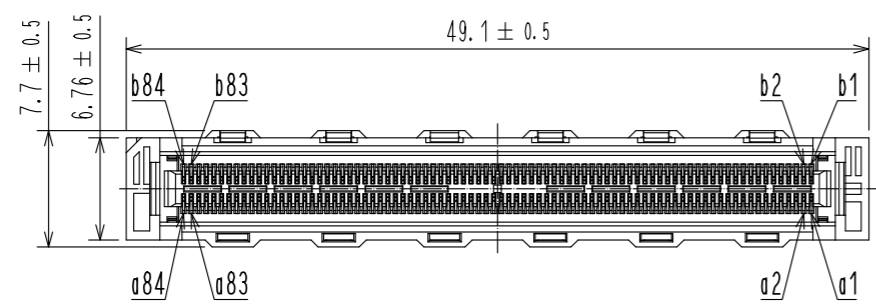

Fig.1 Recommended spacer height (Free)

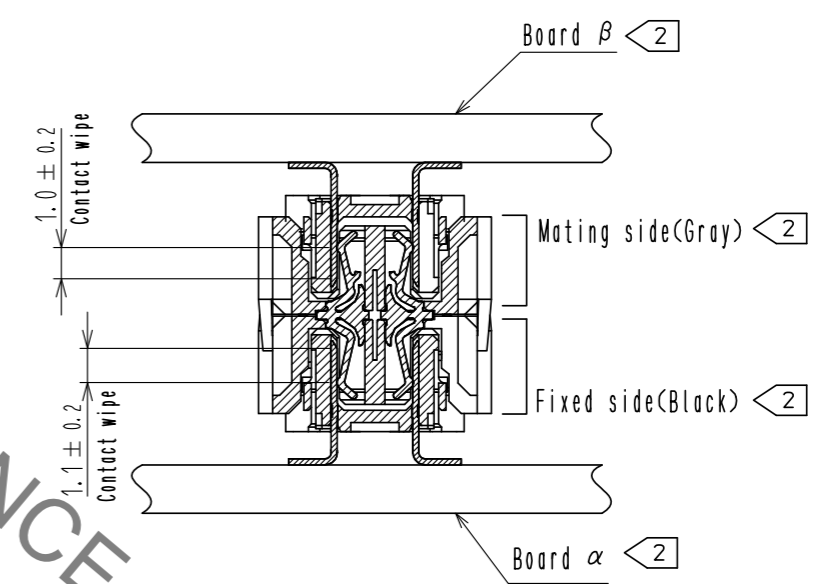

Fig.2 Mating cross section (Free)

Table.1 Stacking height and connector combinations

Board distance (Stacking height)	Header connector of Board α	Interposer	Header connector of Board β	Recommended spacer height(L)
8mm	FX10A-168P-SV(**)	FX10-168IP-8H(03)	FX10A-168P-SV(**)	8 ± 0.127mm
9mm	FX10A-168P-SV1(**)		FX10A-168P-SV(**)	9 ± 0.127mm
10mm	FX10A-168P-SV1(**)		FX10A-168P-SV1(**)	10 ± 0.127mm

- Note.
- 1 The header connectors are decided by board distance (stacking height). Connector combination is shown in Table 1.
 - 2 Fixed side (Black side) of interposer should be mated with header mounted on board α. Mating side (Gray side) should be mated with header mounted on board β.
 - 3 Spacers are required to support the PWB's and protect the SMT solder joints. Recommended spacer height is shown in Table 1.
 - 4 Pin configuration is shown in Table 2. This product consists of 168 Single-ended lines.
 - 5 Lot No. shall be marked on the indicated position.
 - 6 50pcs of this product are packed in soft tray. See Fig.3 for details.

2	LCP(Black)	UL94V-0	4	PS	(Tray)			
1	LCP(Gray)	UL94V-0	3	Copper Alloy	Ni1.5μm+Au0.76μm			
NO.	MATERIAL	FINISH . REMARKS	NO.	MATERIAL	FINISH . REMARKS			
UNITS	mm	SCALE	2 : 1	COUNT	DESCRIPTION OF REVISIONS	DESIGNED	CHECKED	DATE
HIROSE ELECTRIC CO., LTD.		APPROVED : TM. MATSUO	17.07.25	DRAWING NO.		EDC-354338-03-00		
		CHECKED : TM. MATSUO	17.07.25	PART NO.		FX10-168IP-8H(03)		
		DESIGNED : AS. MATSUZAWA	17.07.25	CODE NO.		CL608-0003-9-03		
		DRAWN : XINGYU CHENG	17.07.25			1/2		

Mar.1.2020 Copyright 2020 HIROSE ELECTRIC CO., LTD. All Rights Reserved.
 In case of consideration for using Automotive equipment / device which demand high reliability, kindly contact our sales window correspondents.

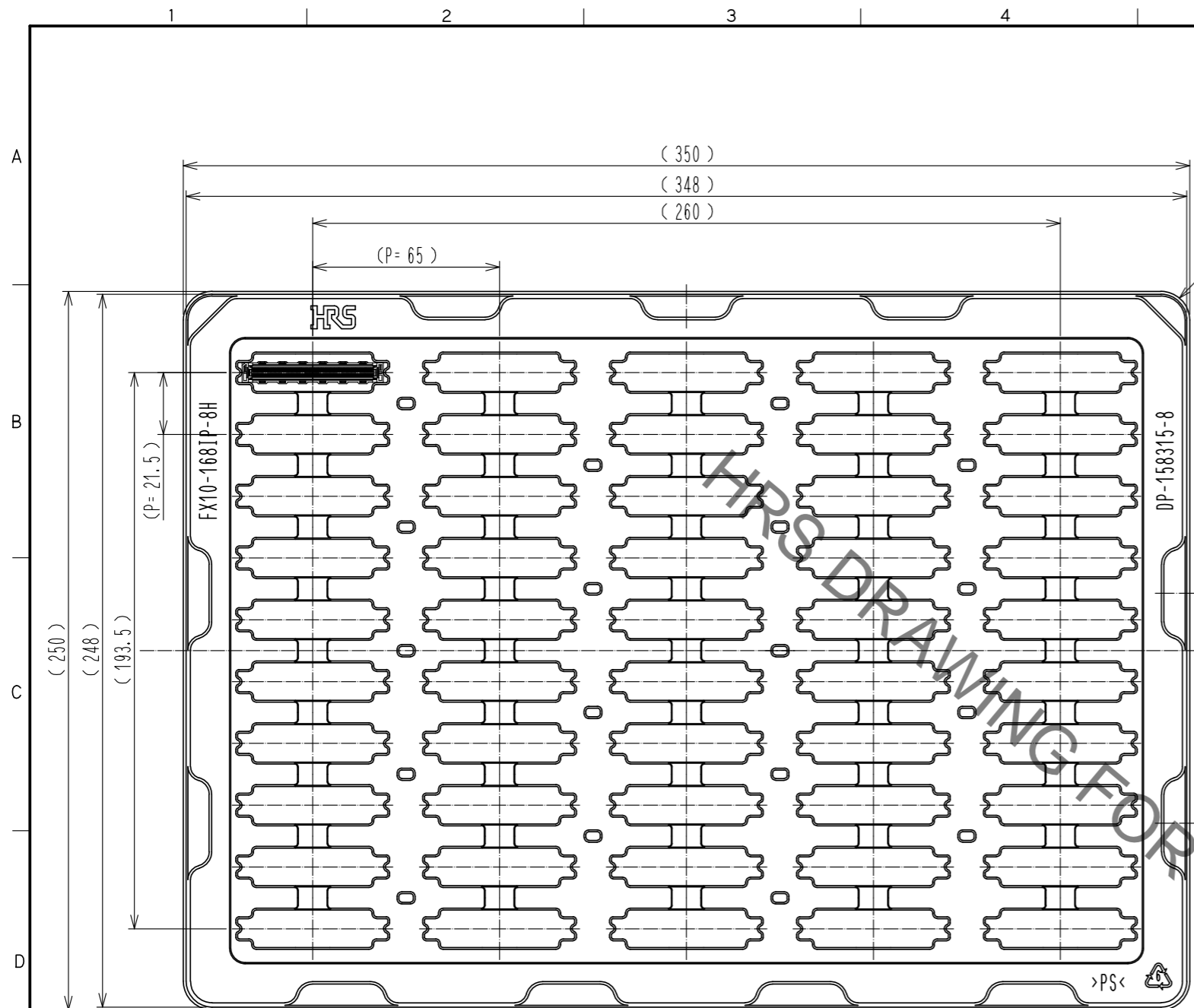

Fig.3 Drawing for packing (1:2) 6

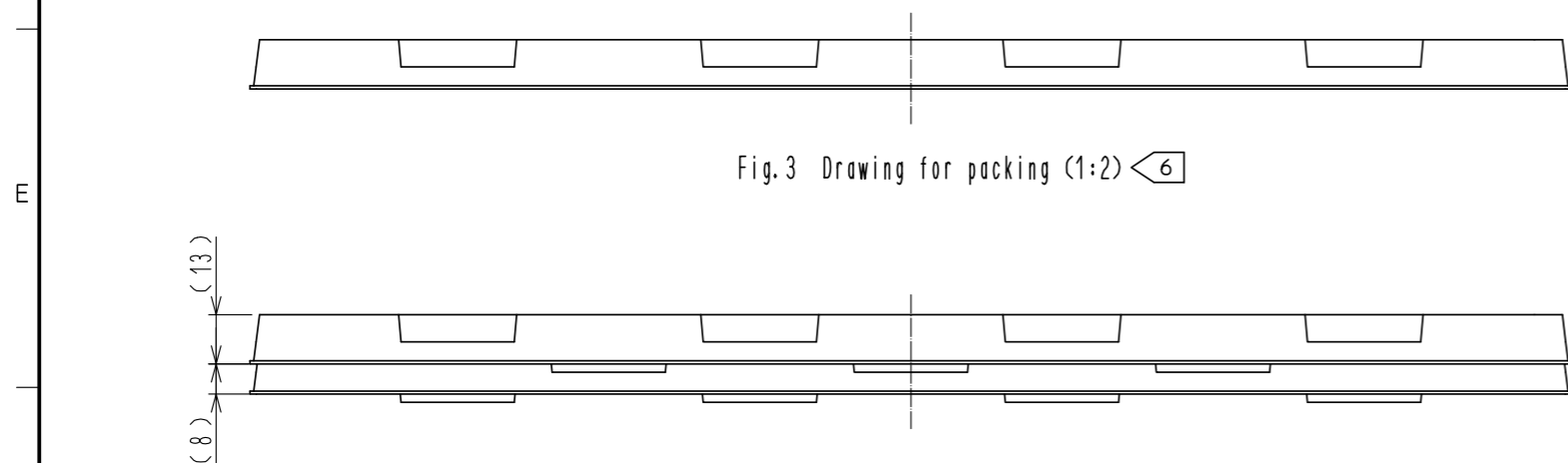

Fig.4 Stacked tray drawing (1:2)

Table.2 Pin configuration of Interposer 4

Row A Pin No.	a1	a2	a3	a4	a5	a6	a7	a8	a9	a10	a11	a12
Pin configuration	S	S	S	S	S	S	S	S	S	S	S	S
Row A Pin No.	a13	a14	a15	a16	a17	a18	a19	a20	a21	a22	a23	a24
Pin configuration	S	S	S	S	S	S	S	S	S	S	S	S
Row A Pin No.	a25	a26	a27	a28	a29	a30	a31	a32	a33	a34	a35	a36
Pin configuration	S	S	S	S	S	S	S	S	S	S	S	S
Row A Pin No.	a37	a38	a39	a40	a41	a42	a43	a44	a45	a46	a47	a48
Pin configuration	S	S	S	S	S	S	S	S	S	S	S	S
Row A Pin No.	a49	a50	a51	a52	a53	a54	a55	a56	a57	a58	a59	a60
Pin configuration	S	S	S	S	S	S	S	S	S	S	S	S
Row A Pin No.	a61	a62	a63	a64	a65	a66	a67	a68	a69	a70	a71	a72
Pin configuration	S	S	S	S	S	S	S	S	S	S	S	S
Row A Pin No.	a73	a74	a75	a76	a77	a78	a79	a80	a81	a82	a83	a84
Pin configuration	S	S	S	S	S	S	S	S	S	S	S	S
Row B Pin No.	b1	b2	b3	b4	b5	b6	b7	b8	b9	b10	b11	b12
Pin configuration	S	S	S	S	S	S	S	S	S	S	S	S
Row B Pin No.	b13	b14	b15	b16	b17	b18	b19	b20	b21	b22	b23	b24
Pin configuration	S	S	S	S	S	S	S	S	S	S	S	S
Row B Pin No.	b25	b26	b27	b28	b29	b30	b31	b32	b33	b34	b35	b36
Pin configuration	S	S	S	S	S	S	S	S	S	S	S	S
Row B Pin No.	b37	b38	b39	b40	b41	b42	b43	b44	b45	b46	b47	b48
Pin configuration	S	S	S	S	S	S	S	S	S	S	S	S
Row B Pin No.	b49	b50	b51	b52	b53	b54	b55	b56	b57	b58	b59	b60
Pin configuration	S	S	S	S	S	S	S	S	S	S	S	S
Row B Pin No.	b61	b62	b63	b64	b65	b66	b67	b68	b69	b70	b71	b72
Pin configuration	S	S	S	S	S	S	S	S	S	S	S	S
Row B Pin No.	b73	b74	b75	b76	b77	b78	b79	b80	b81	b82	b83	b84
Pin configuration	S	S	S	S	S	S	S	S	S	S	S	S

S: Signal

HRS	DRAWING NO.	EDC-354338-03-00
	PART NO.	FX10-168IP-8H(03)
	CODE NO.	CL608-0003-9-03 2/2