

Mar.1.2020 Copyright 2020 HIROSE ELECTRIC CO., LTD. All Rights Reserved.
In case of consideration for using Automotive equipment / device which demand high reliability, kindly contact our sales window correspondents.

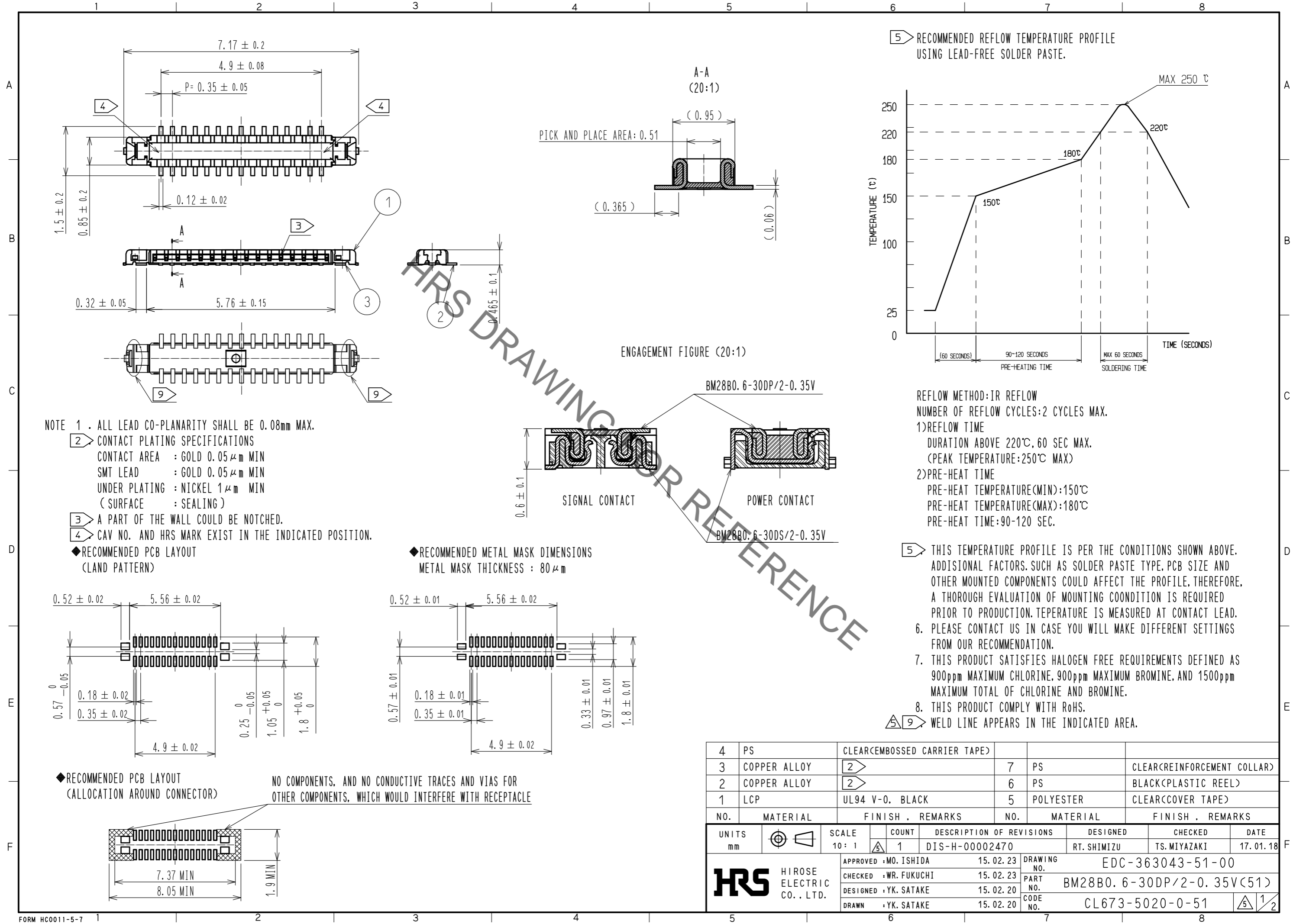

- NOTE 1 . ALL LEAD CO-PLANARITY SHALL BE 0.08mm MAX.
- 2 CONTACT PLATING SPECIFICATIONS
CONTACT AREA : GOLD 0.05 μm MIN
SMT LEAD : GOLD 0.05 μm MIN
UNDER PLATING : NICKEL 1 μm MIN
(SURFACE : SEALING)
- 3 A PART OF THE WALL COULD BE NOTCHED.
- 4 CAV NO. AND HRS MARK EXIST IN THE INDICATED POSITION.
- ◆RECOMMENDED PCB LAYOUT (LAND PATTERN)

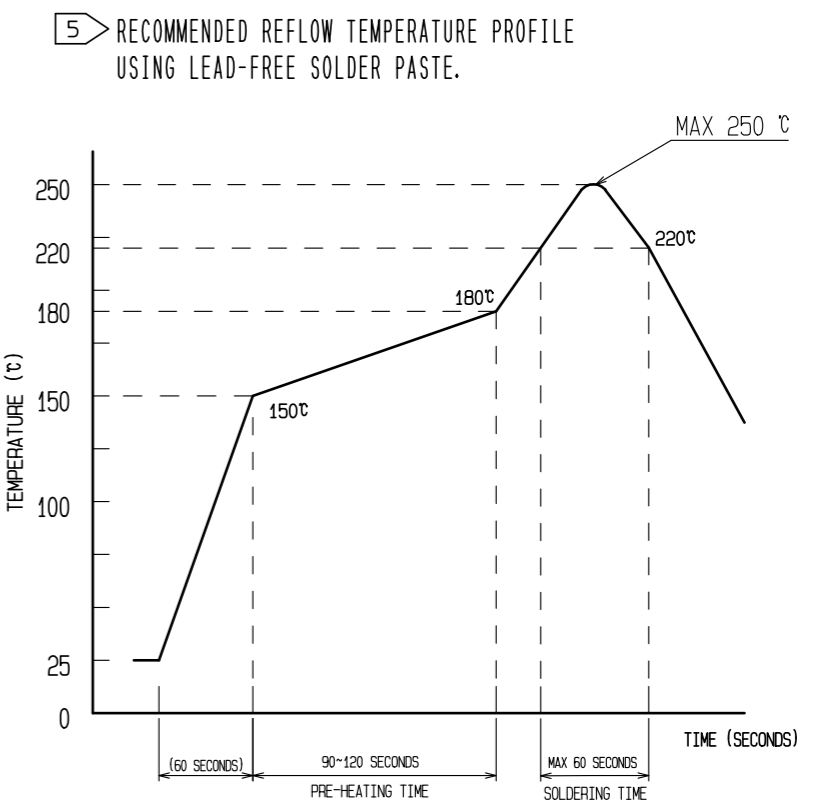
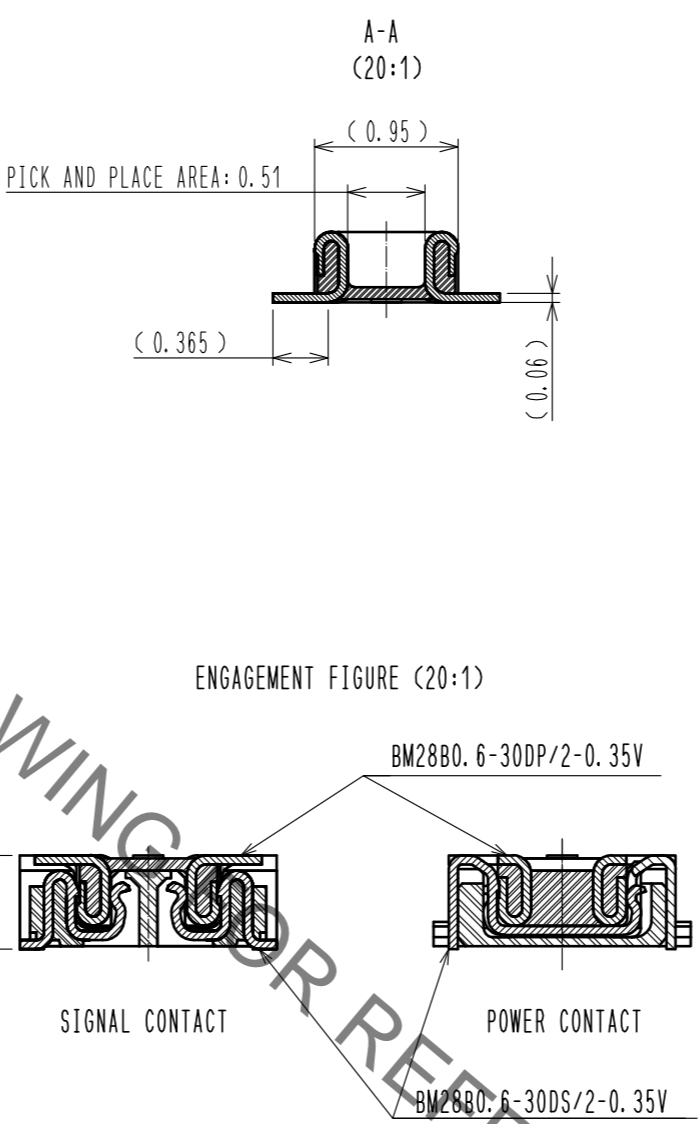
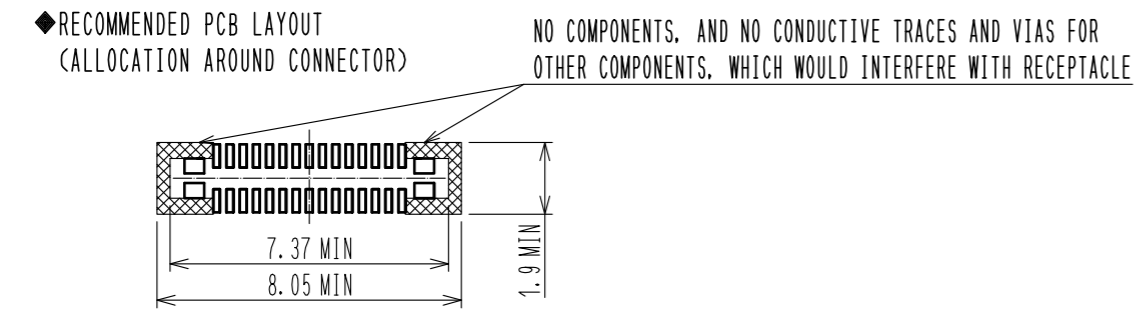
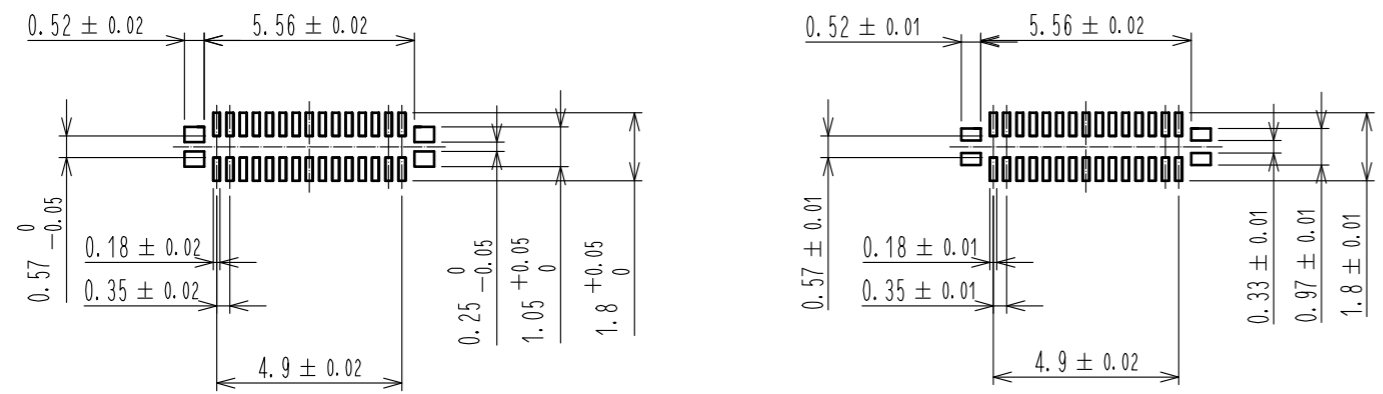

REFLOW METHOD:IR REFLOW
NUMBER OF REFLOW CYCLES:2 CYCLES MAX.

1)REFLOW TIME
DURATION ABOVE 220°C,60 SEC MAX.
(PEAK TEMPERATURE:250°C MAX)

2)PRE-HEAT TIME
PRE-HEAT TEMPERATURE(MIN):150°C
PRE-HEAT TEMPERATURE(MAX):180°C
PRE-HEAT TIME:90-120 SEC.

- 5 THIS TEMPERATURE PROFILE IS PER THE CONDITIONS SHOWN ABOVE. ADDITIONAL FACTORS, SUCH AS SOLDER PASTE TYPE, PCB SIZE AND OTHER MOUNTED COMPONENTS COULD AFFECT THE PROFILE, THEREFORE, A THOROUGH EVALUATION OF MOUNTING COONDITION IS REQUIRED PRIOR TO PRODUCTION. TEPERATURE IS MEASURED AT CONTACT LEAD.
6. PLEASE CONTACT US IN CASE YOU WILL MAKE DIFFERENT SETTINGS FROM OUR RECOMMENDATION.
7. THIS PRODUCT SATISFIES HALOGEN FREE REQUIREMENTS DEFINED AS 900ppm MAXIMUM CHLORINE, 900ppm MAXIMUM BROMINE, AND 1500ppm MAXIMUM TOTAL OF CHLORINE AND BROMINE.
8. THIS PRODUCT COMPLY WITH ROHS.
- 9 WELD LINE APPEARS IN THE INDICATED AREA.

4	PS	CLEAR(EMBOSSED CARRIER TAPE)					
3	COPPER ALLOY	2	7	PS	CLEAR(REINFORCEMENT COLLAR)		
2	COPPER ALLOY	2	6	PS	BLACK(PLASTIC REEL)		
1	LCP	UL94 V-0, BLACK	5	POLYESTER	CLEAR(COVER TAPE)		
NO.	MATERIAL	FINISH . REMARKS	NO.	MATERIAL	FINISH . REMARKS		
UNITS mm		SCALE 10:1	COUNT 1	DESCRIPTION OF REVISIONS DIS-H-00002470	DESIGNED RT. SHIMIZU	CHECKED TS. MIYAZAKI	DATE 17. 01. 18
HRS HIROSE ELECTRIC CO., LTD.		APPROVED :MO. ISHIDA	15. 02. 23	DRAWING NO. EDC-363043-51-00			
		CHECKED :WR. FUKUCHI	15. 02. 23	PART NO. BM28B0. 6-30DP/2-0. 35V(51)			
		DESIGNED :YK. SATAKE	15. 02. 20	CODE NO. CL673-5020-0-51			
		DRAWN :YK. SATAKE	15. 02. 20	1/2			

Mar.1.2020 Copyright 2020 HIROSE ELECTRIC CO., LTD. All Rights Reserved.
 In case of consideration for using Automotive equipment / device which demand high reliability, kindly contact our sales window correspondents.

EMBOSED CARRIER TAPE PACKAGING (5:1)

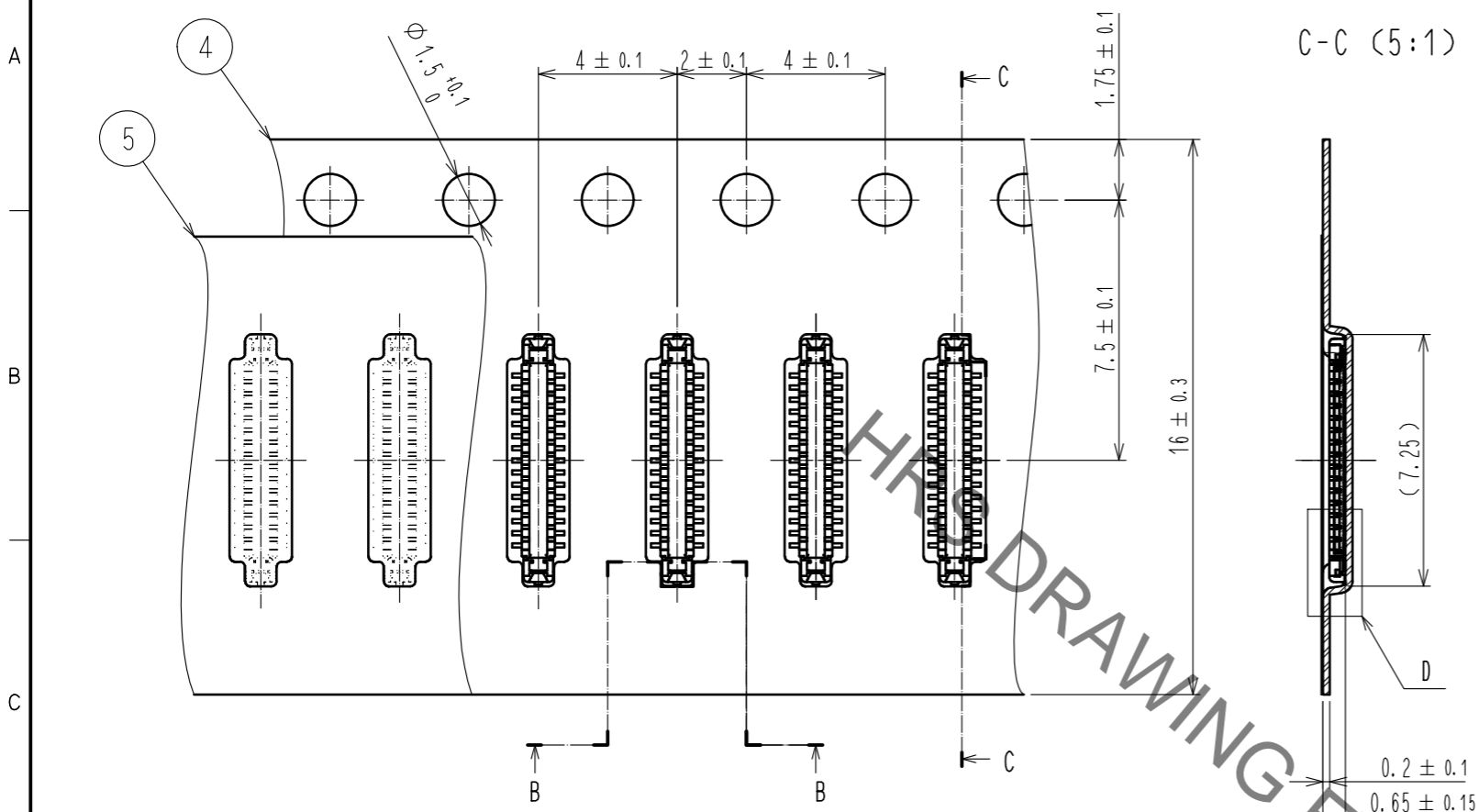

B-B (5:1)

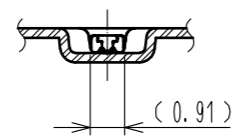

C-C (5:1)

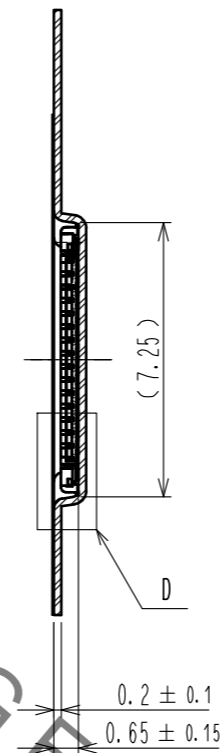

D (10:1)

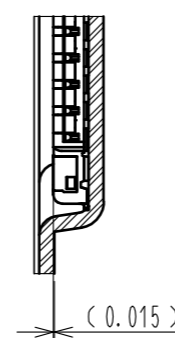

STYLE AND DIMENSION OF REEL (FREE)

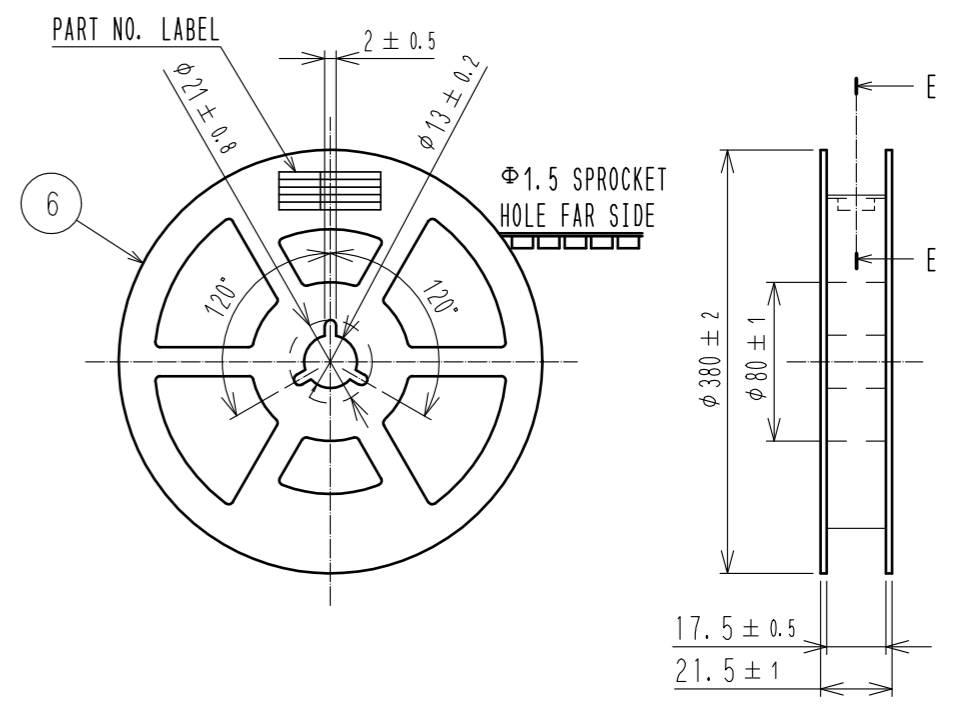

E-E (FREE)

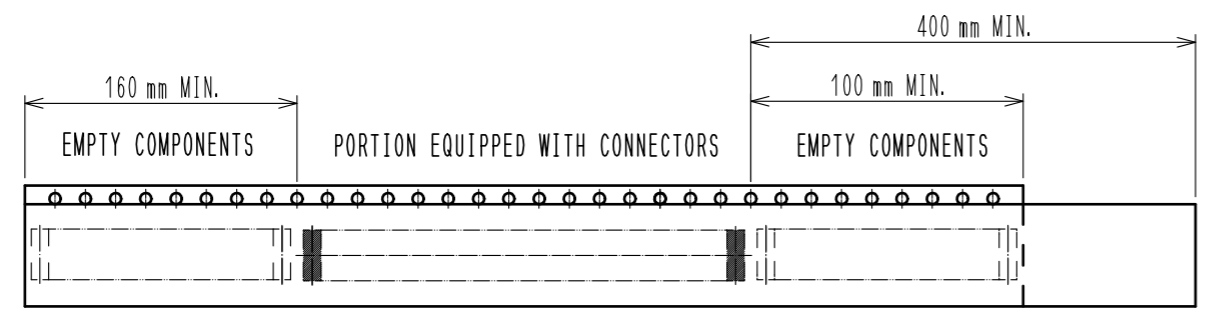
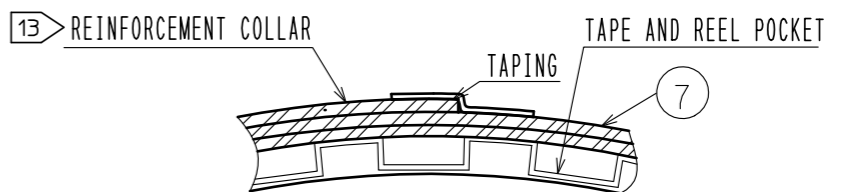

12 TAPING(FREE)

DETAIL OF PART NO. LABEL

製造年月日	** ** *	DATA OF MANUFACTURED
製品コード	CL0673-****-**	CODE NO.
製品名	BM28B0.6-**	PART NO.
数量	20,000	QUANTITY
納入者	ヒロセ電機(株)	SUPPLIER

- 10 . PER REEL 20,000 CONNECTORS.
- 11 . THE DIMENSIONS IN PARENTHESES ARE FOR REFERENCE.
- 12 . REFER TO JIS C 0806 (PACKAGING OF COMPONENTS FOR AUTOMATIC HANDLING)
- 13 . AFTER PACKAGING, ROLL 2 METERS OF THE REINFORCEMENT COLLAR TO OUTER CIRCUMFERENCE OF TAPE AND REEL POCKET, AND TAPE DOWN AT THE END THE COLLAR.

HRS	DRAWING NO.	EDC-363043-51-00
	PART NO.	BM28B0.6-30DP/2-0.35V<51>
	CODE NO.	CL673-5020-0-51
		△ 2/2