

Oct.1.2019 Copyright 2019 HIROSE ELECTRIC CO., LTD. All Rights Reserved.
 In case of consideration for using Automotive equipment / device which demand high reliability, kindly contact our sales window correspondents.

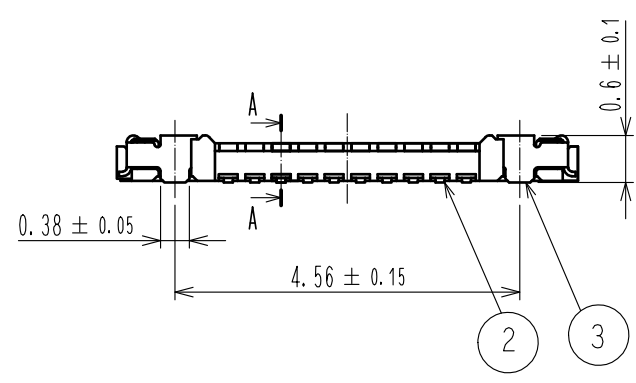

NOTE 1 . ALL LEAD CO-PLANARITY SHALL BE 0.08mm MAX.
 2 CONTACT PLATING SPECIFICATIONS
 CONTACT AREA : GOLD 0.05 μm MIN
 SMT LEAD : GOLD 0.05 μm MIN
 UNDER PLATING : NICKEL 1 μm MIN
 (SURFACE : SEALING)
 3 CAV NO. AND HRS MARK EXIST IN THE INDICATED POSITION

◆RECOMMENDED PCB LAYOUT

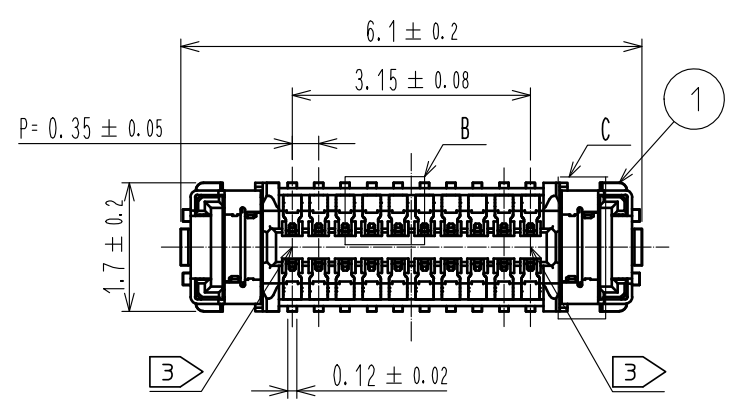
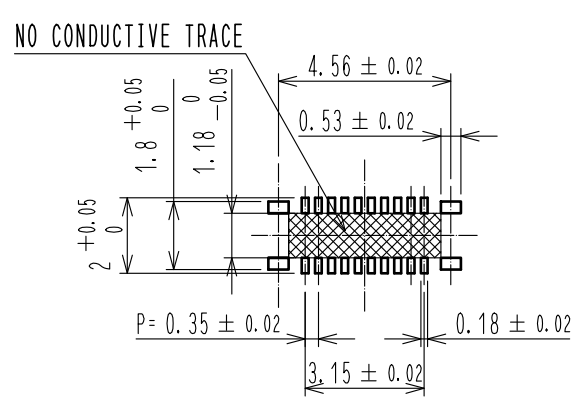

◆RECOMMENDED METAL MASK DIMENSIONS
 METAL MASK THICKNESS : 80 μm

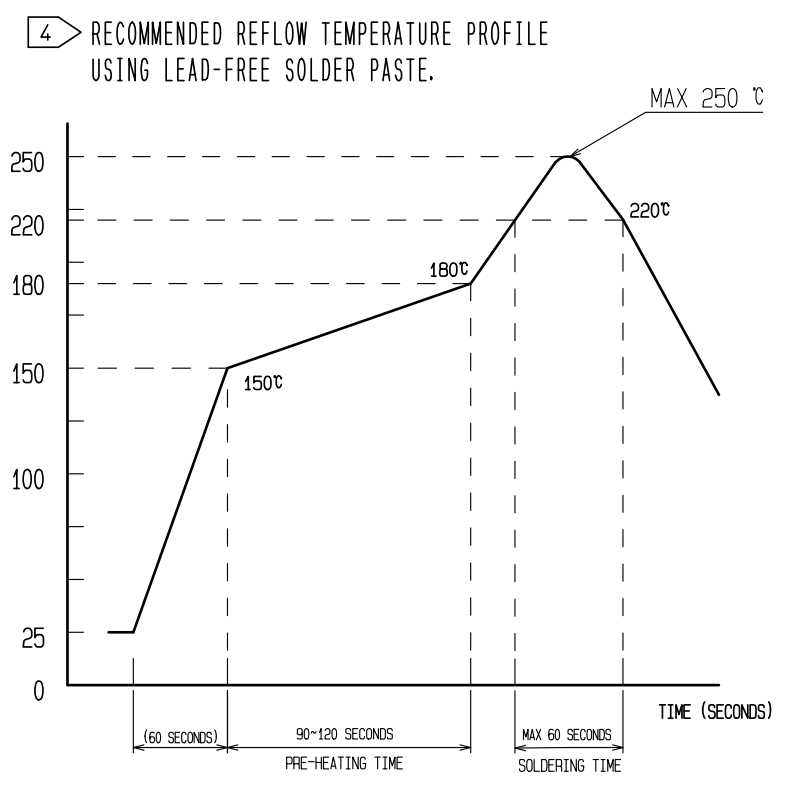
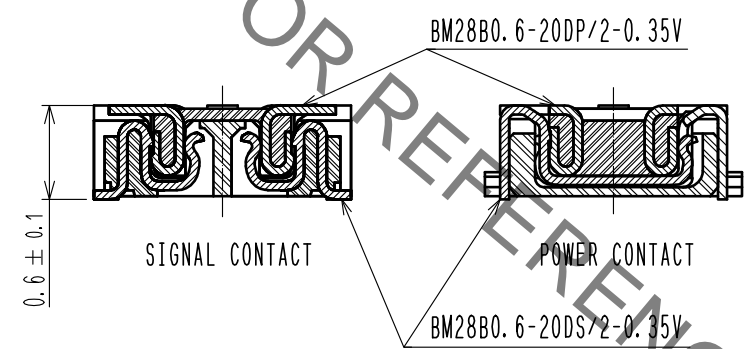
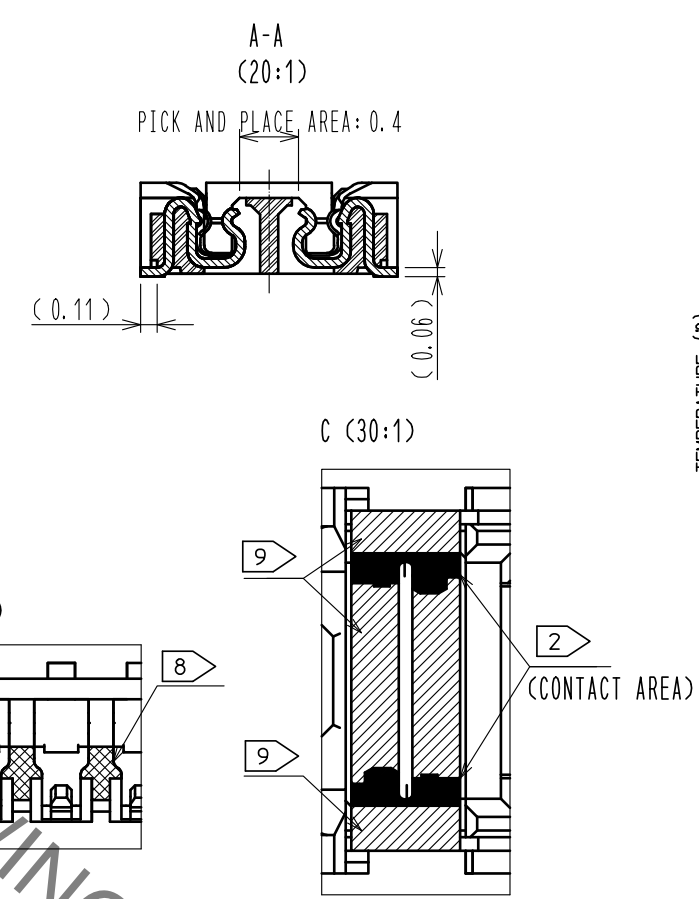
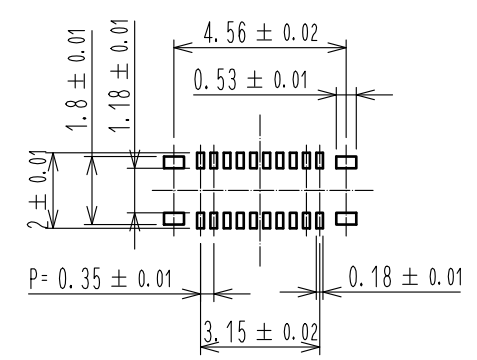

REFLOW METHOD:IR REFLOW
 NUMBER OF REFLOW CYCLES:2 CYCLES MAX.
 1)REFLOW TIME
 DURATION ABOVE 220°C, 60 SEC MAX.
 (PEAK TEMPERATURE:250°C MAX)
 2)PRE-HEAT TIME
 PRE-HEAT TEMPERATURE(MIN):150°C
 PRE-HEAT TEMPERATURE(MAX):180°C
 PRE-HEAT TIME:90-120 SEC.

- 4 THIS TEMPERATURE PROFILE IS PER THE CONDITIONS SHOWN ABOVE. ADDITIONAL FACTORS, SUCH AS SOLDER PASTE TYPE, PCB SIZE AND OTHER MOUNTED COMPONENTS COULD AFFECT THE PROFILE, THEREFORE, A THOROUGH EVALUATION OF MOUNTING COONDITION IS REQUIRED PRIOR TO PRODUCTION. TEPERATURE IS MEASURED AT CONTACT LEAD.
- 5. PLEASE CONTACT US IN CASE YOU WILL MAKE DIFFERENT SETTINGS FROM OUR RECOMMENDATION.
- 6. THIS PRODUCT SATISFIES HALOGEN FREE REQUIREMENTS DEFINED AS 900ppm MAXIMUM CHLORINE, 900ppm MAXIMUM BROMINE, AND 1500ppm MAXIMUM TOTAL OF CHLORINE AND BROMINE.
- 7. THIS PRODUCT COMPLY WITH RoHS.
- 8 WELD LINE APPEARS IN THE INDICATED POSITION.
- 9 NO GOLD PLATING IS ACCEPTABLE FOR THIS AREA.

4	PS	CLEAR(EMBOSSD CARRIER TAPE)			
3	COPPER ALLOY	2	7	PS	CLEAR (REINFORCEMENT COLLAR)
2	COPPER ALLOY	2	6	PS	BLACK (PLASTIC REEL)
1	LCP	UL94 V-0, BLACK	5	POLYESTER	CLEAR (COVER TAPE)
NO.	MATERIAL	FINISH . REMARKS	NO.	MATERIAL	FINISH . REMARKS
UNITS mm	⊙	SCALE 10 : 1	COUNT	DESCRIPTION OF REVISIONS	DESIGNED
					CHECKED
					DATE
APPROVED :MO. ISHIDA		17. 01. 30		DRAWING NO. EDC-365212-61-00	
CHECED : TS. MIYAZAKI		17. 01. 30		PART NO. BM28B0. 6-20DS/2-0. 35V<61>	
DESIGNED : RT. SHIMIZU		17. 01. 27		CODE NO. CL673-5040-0-61	
DRAWN : SN. NUMAZAKI		17. 01. 23		1/2	

Oct.1.2019 Copyright 2019 HIROSE ELECTRIC CO., LTD. All Rights Reserved.
In case of consideration for using Automotive equipment / device which demand high reliability, kindly contact our sales window correspondents.

EMBOSED CARRIER TAPE PACKAGING (5:1)

E-E (5:1)

STYLE AND DIMENSION OF REEL (FREE)

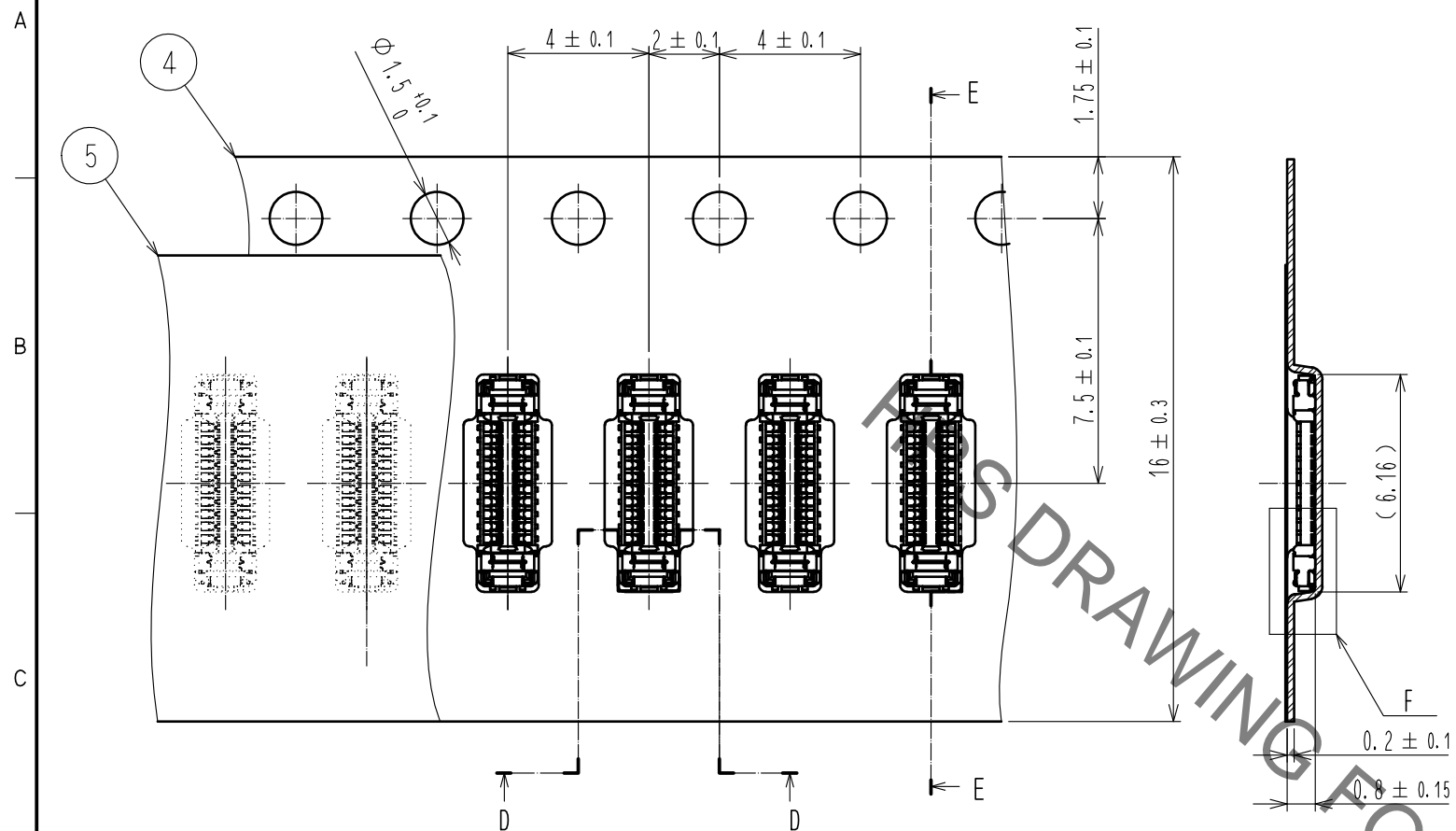

D-D (5:1)

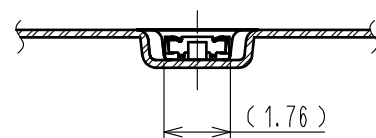

DIRECTION OF UNREELING

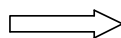

F (10:1)

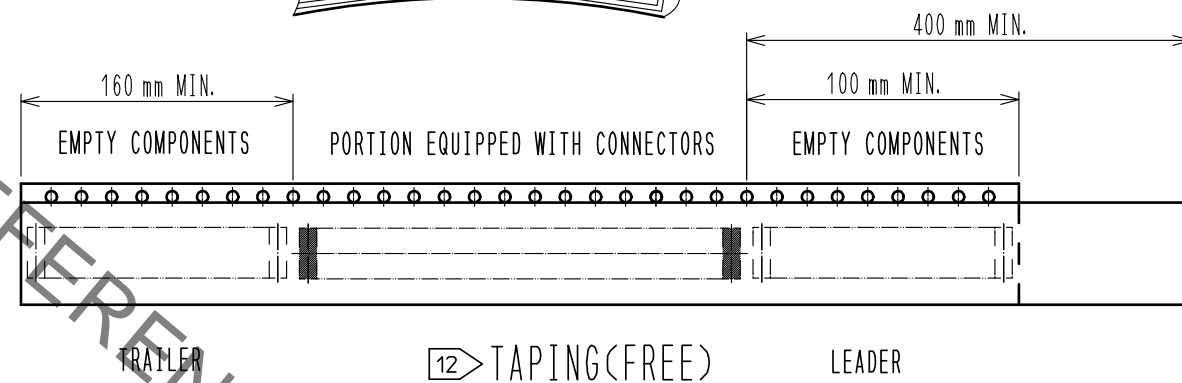
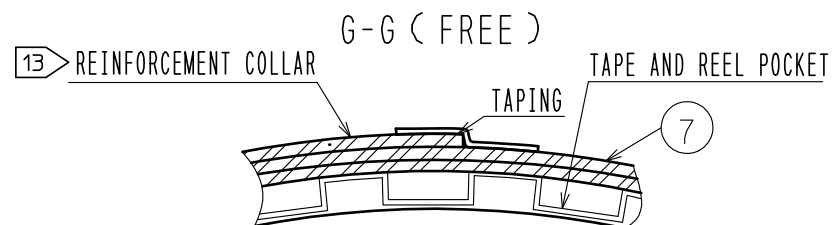
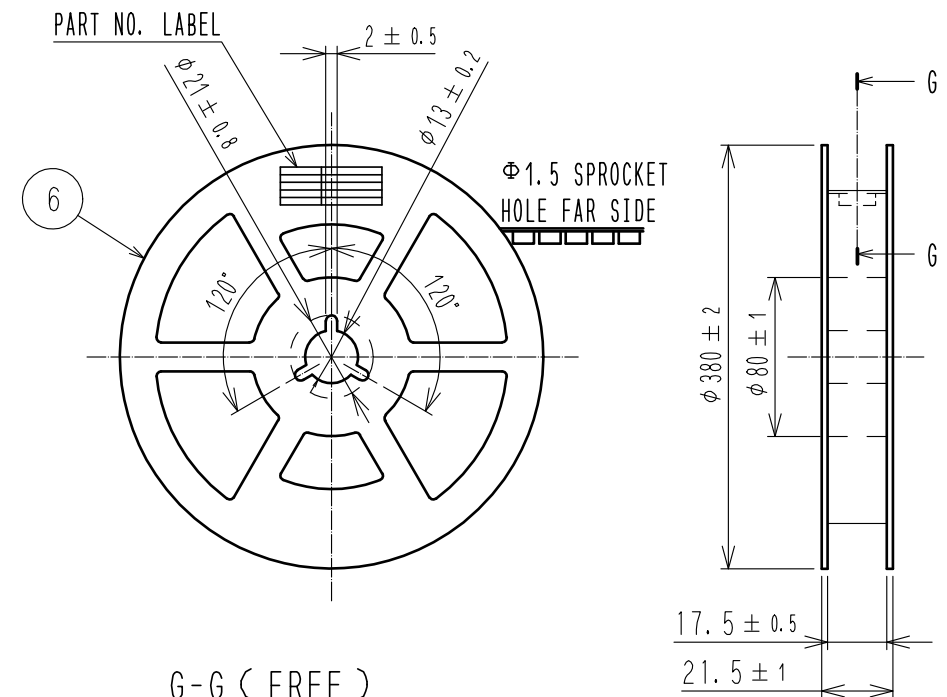
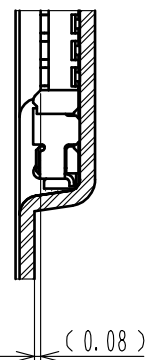

DETAIL OF PART NO. LABEL

製造年月日	** ** *
製品コード	CL0673-****-**
製品名	BM28B0.6-**
数量	20,000
納入者	ヒロセ電機(株)

DATA OF MANUFACTURED
CODE NO.
PART NO.
QUANTITY
SUPPLIER

- 10 . PER REEL 20,000 CONNECTORS.
- 11 . THE DIMENSIONS IN PARENTHESES ARE FOR REFERENCE.
- 12 . REFER TO JIS C 0806, IEC 60286-3(PACKAGING OF COMPONENTS FOR AUTOMATIC HANDLING)
- 13 . AFTER PACKAGING, ROLL 2 METERS OF THE REINFORCEMENT COLLAR TO OUTER CIRCUMFERENCE OF TAPE AND REEL POCKET. AND TAPE DOWN AT THE END THE COLLAR.

HRS	DRAWING NO.	EDC-365212-61-00
	PART NO.	BM28B0.6-20DS/2-0.35V<61>
	CODE NO.	CL673-5040-0-61
		△ 2/2