

Oct.1.2019 Copyright 2019 HIROSE ELECTRIC CO., LTD. All Rights Reserved.
In case of consideration for using Automotive equipment / device which demand high reliability, kindly contact our sales window correspondents.

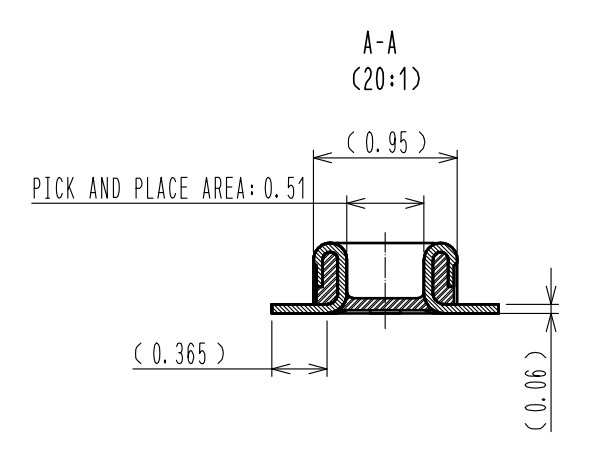

ENGAGEMENT FIGURE (20:1)

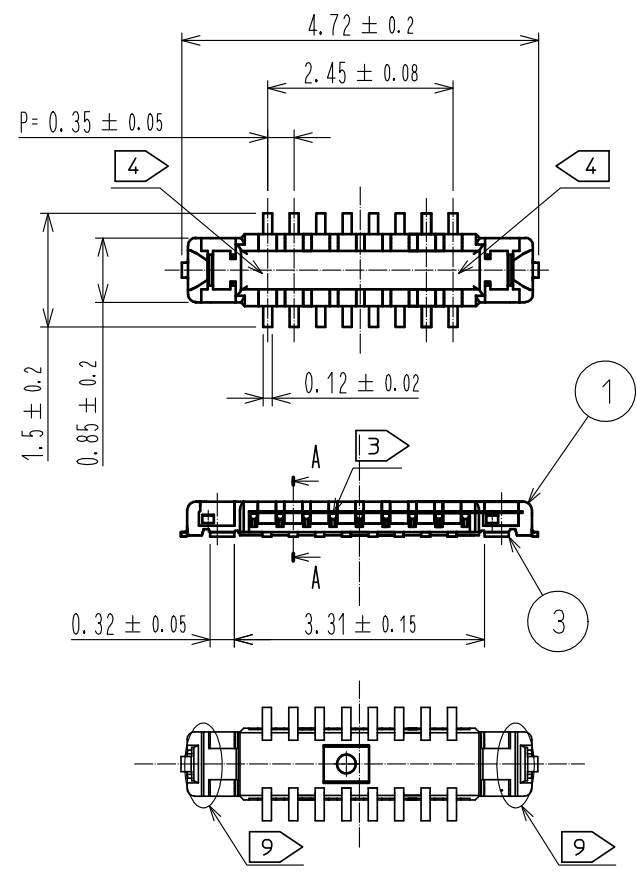
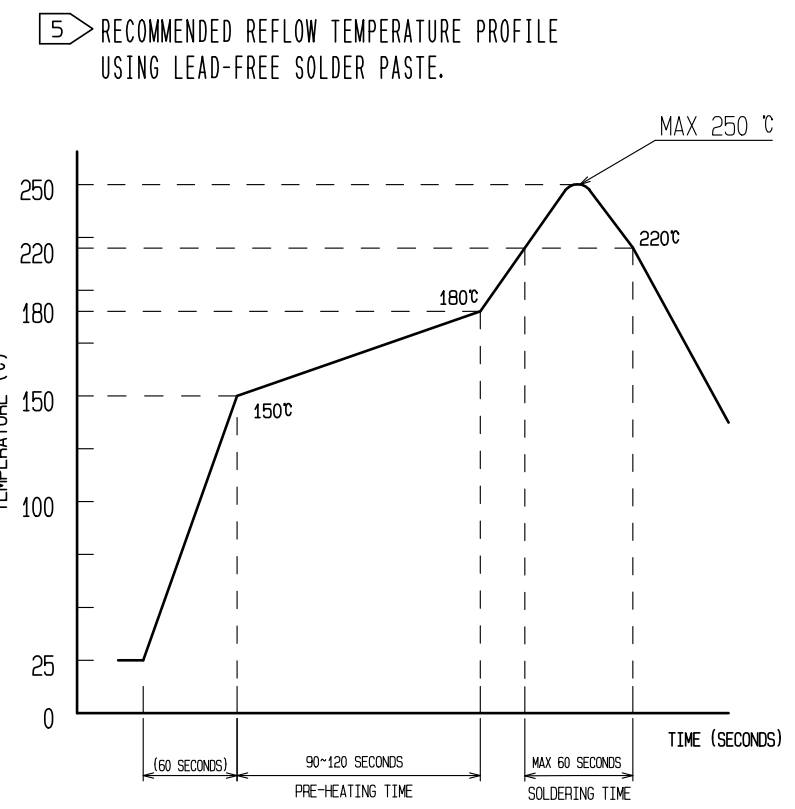
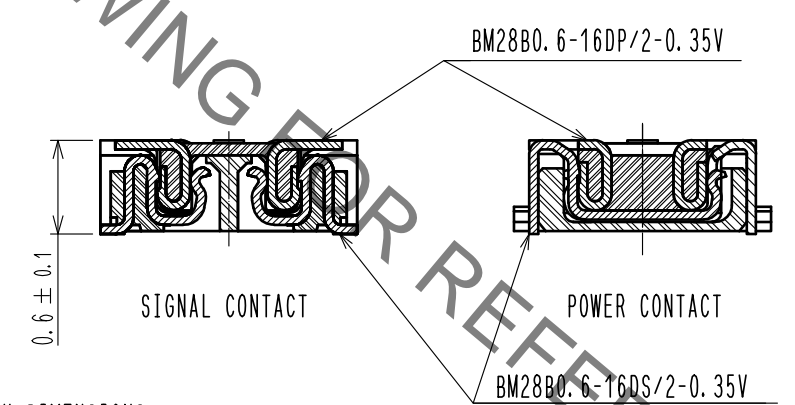

REFLOW METHOD: IR REFLOW
 NUMBER OF REFLOW CYCLES: 2 CYCLES MAX.
 1) REFLOW TIME
 DURATION ABOVE 220°C: 60 SEC MAX.
 (PEAK TEMPERATURE: 250°C MAX)
 2) PRE-HEAT TIME
 PRE-HEAT TEMPERATURE (MIN): 150°C
 PRE-HEAT TEMPERATURE (MAX): 180°C
 PRE-HEAT TIME: 90-120 SEC.

THIS TEMPERATURE PROFILE IS PER THE CONDITIONS SHOWN ABOVE. ADDITIONAL FACTORS, SUCH AS SOLDER PASTE TYPE, PCB SIZE AND OTHER MOUNTED COMPONENTS COULD AFFECT THE PROFILE. THEREFORE, A THOROUGH EVALUATION OF MOUNTING COONDITION IS REQUIRED PRIOR TO PRODUCTION. TEMPERATURE IS MEASURED AT CONTACT LEAD.
 6. PLEASE CONTACT US IN CASE YOU WILL MAKE DIFFERENT SETTINGS FROM OUR RECOMMENDATION.
 7. THIS PRODUCT SATISFIES HALOGEN FREE REQUIREMENTS DEFINED AS 900ppm MAXIMUM CHLORINE, 900ppm MAXIMUM BROMINE, AND 1500ppm MAXIMUM TOTAL OF CHLORINE AND BROMINE.
 8. THIS PRODUCT COMPLY WITH ROHS.
 WELD LINE APPEARS IN THE INDICATED AREA.

NOTE 1. ALL LEAD CO-PLANARITY SHALL BE 0.08mm MAX.
 2 CONTACT PLATING SPECIFICATIONS
 CONTACT AREA : GOLD 0.05 μm MIN
 SMT LEAD : GOLD 0.05 μm MIN
 UNDER PLATING : NICKEL 1 μm MIN
 (SURFACE : SEALING)
 3 A PART OF THE WALL COULD BE NOTCHED.
 4 CAV NO. AND HRS MARK EXIST IN THE INDICATED POSITION.
 ◆ RECOMMENDED PCB LAYOUT (LAND PATTERN)
 ◆ RECOMMENDED METAL MASK DIMENSIONS
 METAL MASK THICKNESS : 80 μm

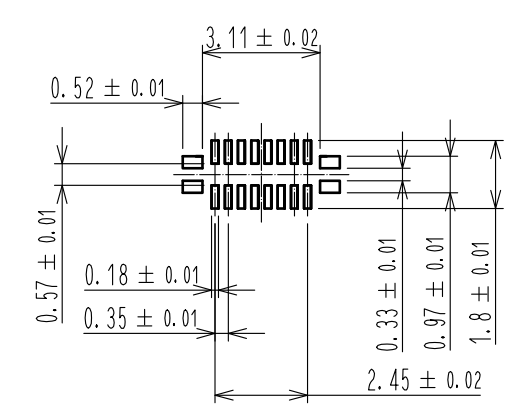
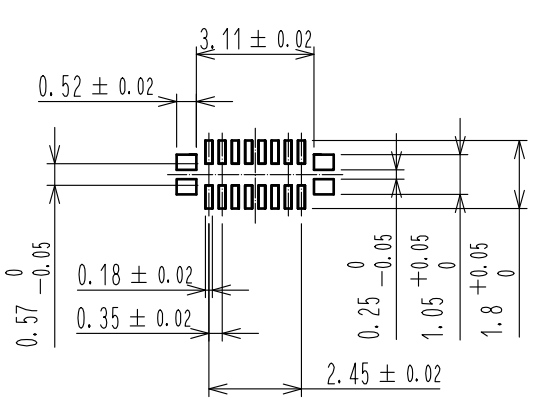

◆ RECOMMENDED PCB LAYOUT (ALLOCATION AROUND CONNECTOR)
 NO COMPONENTS, AND NO CONDUCTIVE TRACES AND VIAS FOR OTHER COMPONENTS, WHICH WOULD INTERFERE WITH RECEPTACLE

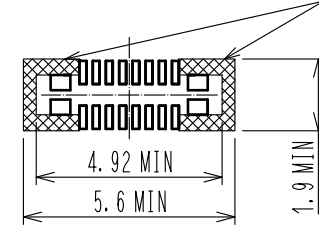

4	PS	CLEAR(EMBOSSED CARRIER TAPE)			
3	COPPER ALLOY	2	7	PS	CLEAR(REINFORCEMENT COLLAR)
2	COPPER ALLOY	2	6	PS	BLACK(PLASTIC REEL)
1	LCP	UL94 V-0, BLACK	5	POLYESTER	CLEAR(COVER TAPE)
NO.	MATERIAL	FINISH . REMARKS	NO.	MATERIAL	FINISH . REMARKS
UNITS	mm	SCALE 10:1	COUNT 1	DESCRIPTION OF REVISIONS	DESIGNED RT. SHIMIZU
				DIS-H-00002470	CHECKED TS. MIYAZAKI
					DATE 17.01.18
APPROVED : MO. ISHIDA		16.07.04		DRAWING NO. EDC-370837-51-01	
CHECKED : TS. MIYAZAKI		16.07.04		PART NO. BM28B0.6-16DP/2-0.35V(51)	
DESIGNED : YT. TAKAGI		16.07.04		CODE NO. CL673-5066-0-51	
DRAWN : SN. NUMAZAKI		16.07.04		1/2	

Oct.1.2019 Copyright 2019 HIROSE ELECTRIC CO., LTD. All Rights Reserved.
 In case of consideration for using Automotive equipment / device which demand high reliability, kindly contact our sales window correspondents.

EMBOSSED CARRIER TAPE PACKAGING (5:1)

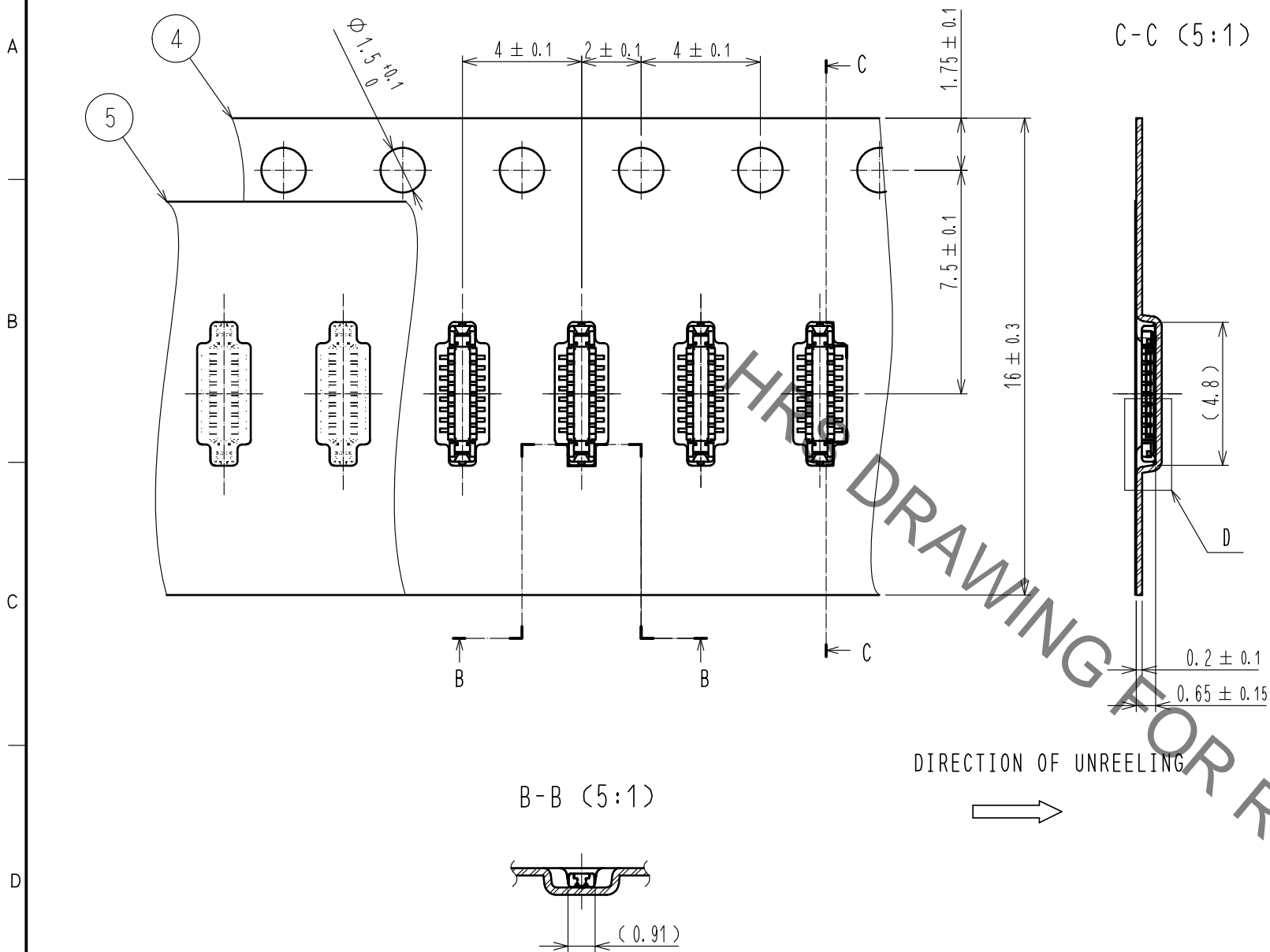

STYLE AND DIMENSION OF REEL (FREE)

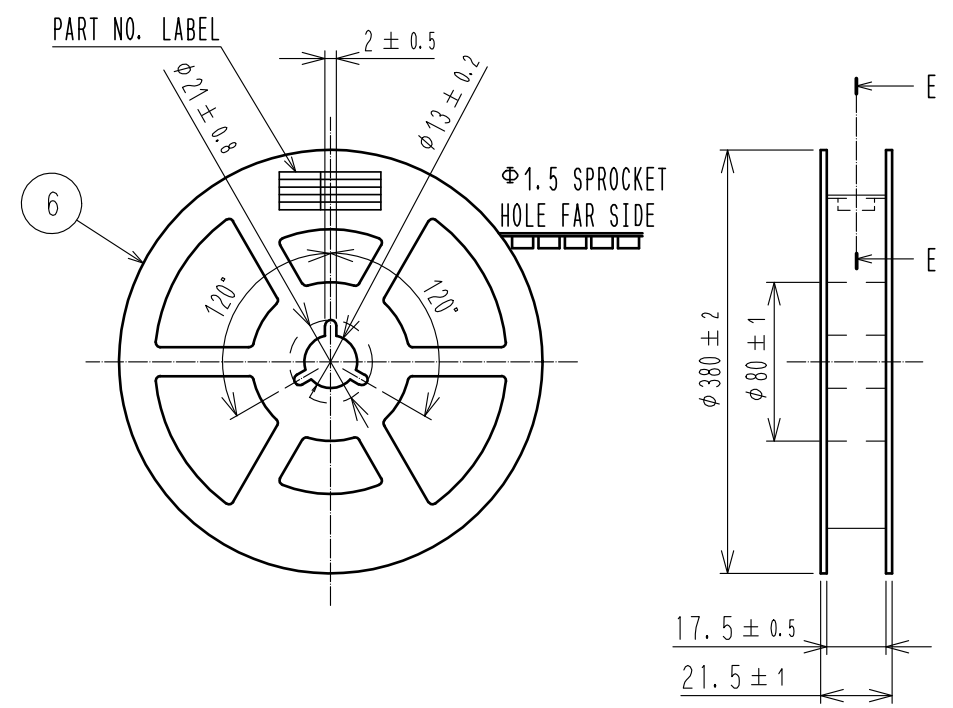

E-E (FREE)

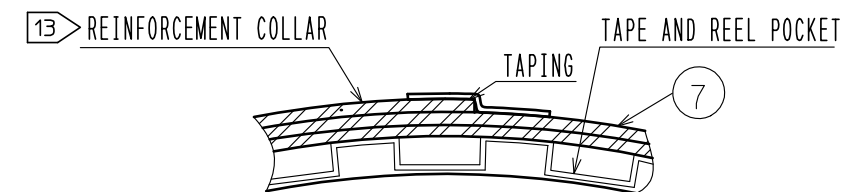

D (10:1)

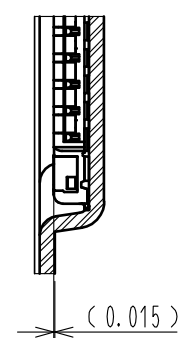

DETAIL OF PART NO. LABEL

製造年月日	** ** *	DATA OF MANUFACTURED
製品コード	CL673-5066-0-51	CODE NO.
製品名	BM28B0.6-16DP/2-0.35V(51)	PART NO.
数量	20,000	QUANTITY
納入者	ヒロセ電機(株)	SUPPLIER

- 10 . PER REEL 20,000 CONNECTORS.
- 11 . THE DIMENSIONS IN PARENTHESES ARE FOR REFERENCE.
- 12 > REFER TO JIS C 0806, IEC 60286-3(PACKAGING OF COMPONENTS FOR AUTOMATIC HANDLING)
- 13 > AFTER PACKAGING, ROLL 2 METERS OF THE REINFORCEMENT COLLAR TO OUTER CIRCUMFERENCE OF TAPE AND REEL POCKET. AND TAPE DOWN AT THE END THE COLLAR.

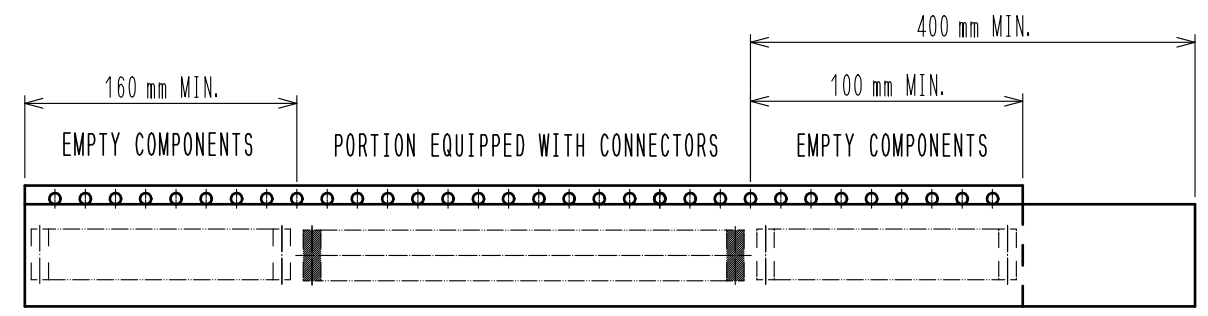

12 > TAPING(FREE)

HRS	DRAWING NO.	EDC-370837-51-01	
	PART NO.	BM28B0.6-16DP/2-0.35V(51)	
	CODE NO.	CL673-5066-0-51	\triangle 2/2
	FORM	HC0011-5-8 1	