

Nov.1.2020 Copyright 2020 HIROSE ELECTRIC CO., LTD. All Rights Reserved.  
In case of consideration for using Automotive equipment / device which demand high reliability, kindly contact our sales window correspondents.

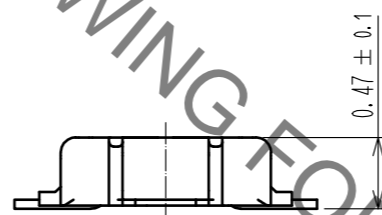
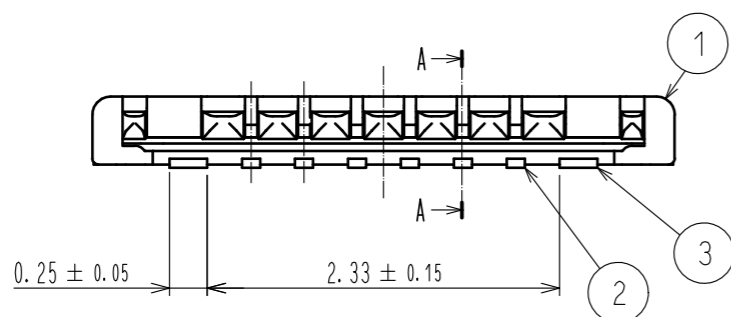
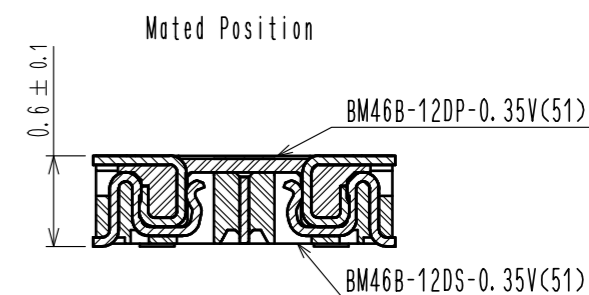
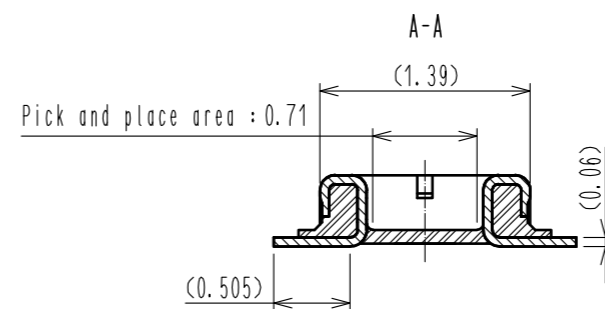
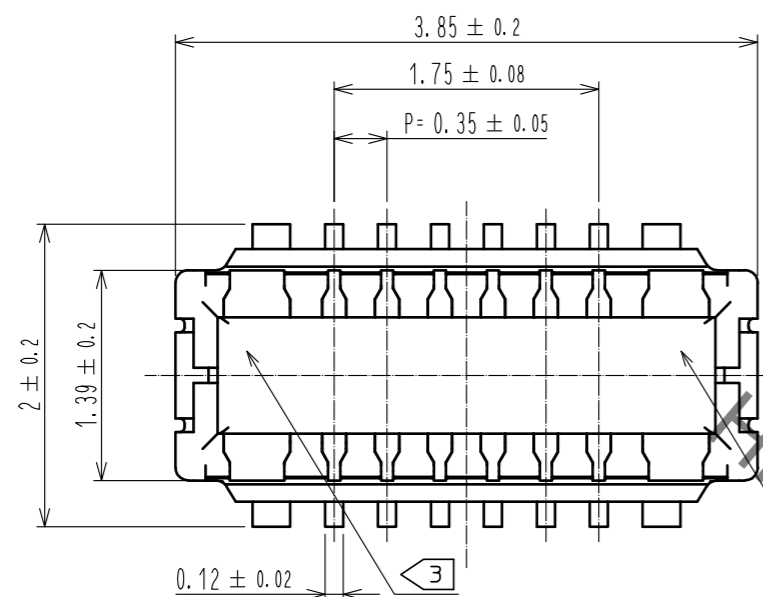

- NOTE 1 . ALL LEAD CO-PLANARITY SHALL BE 0.08mm MAX.  
 2 CONTACT PLATING SPECIFICATIONS  
 CONTACT AREA : GOLD 0.03 μm MIN  
 SMT LEAD : GOLD 0.03 μm MIN  
 UNDER PLATING : NICKEL 1 μm MIN  
 ( SURFACE : SEALING )  
 3 HRS MARK AND CAV No. ARE INDICATED IN APPROX. POSITION SHOWN.

4	PS	SMOKE GRAY, EMBOSSED CARRIER TAPE					
3	COPPER ALLOY	2	7	PS	CLEAR, REINFORCEMENT COLLAR		
2	COPPER ALLOY	2	6	PS	BLACK, PLASTIC REEL		
1	LCP	UL94 V-0, BLACK	5	POLYESTER	CLEAR, COVER TAPE		
NO.	MATERIAL	FINISH, REMARKS	NO.	MATERIAL	FINISH, REMARKS		
UNITS mm		SCALE 20 : 1	COUNT 1	DESCRIPTION OF REVISIONS DIS-H-00005280	DESIGNED RH. KITAGAWA	CHECKED TS. MIYAZAKI	DATE 20190918
<b>HRS</b> HIROSE ELECTRIC CO., LTD.		APPROVED : WR. FUKUCHI 20180717	DRAWING NO. EDC-378956-51-03				
		CHECKED : TY. 001 20180717	PART NO. BM46B-12DP-0.35V(51)				
		DESIGNED : RH. KITAGAWA 20180717	CODE NO. CL673-7055-0-51				
		DRAWN : SN. NUMAZAKI 20180717					

Nov.1.2020 Copyright 2020 HIROSE ELECTRIC CO., LTD. All Rights Reserved.  
In case of consideration for using Automotive equipment / device which demand high reliability, kindly contact our sales window correspondents.

RECOMMENDED PCB LAYOUT (10:1)

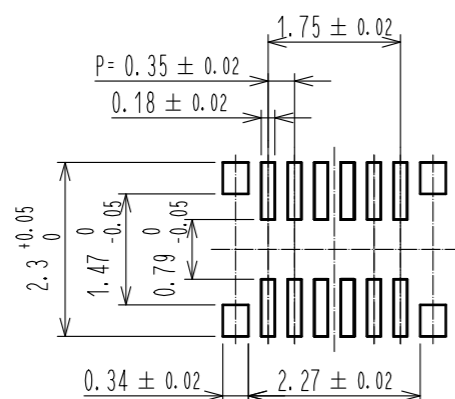

RECOMMENDED METAL MASK DIMENSIONS (10:1)  $\triangle$   
METAL MASK THICKNESS : 80  $\mu$ m

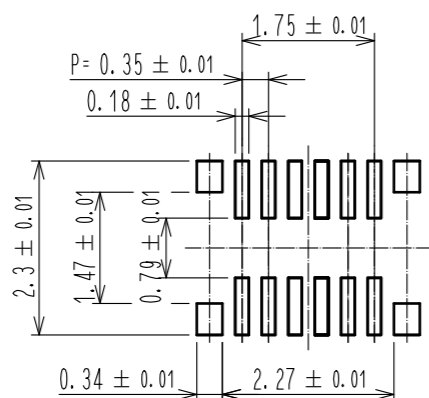

4 RECOMMENDED REFLOW TEMPERATURE PROFILE USING LEAD-FREE SOLDER PASTE.

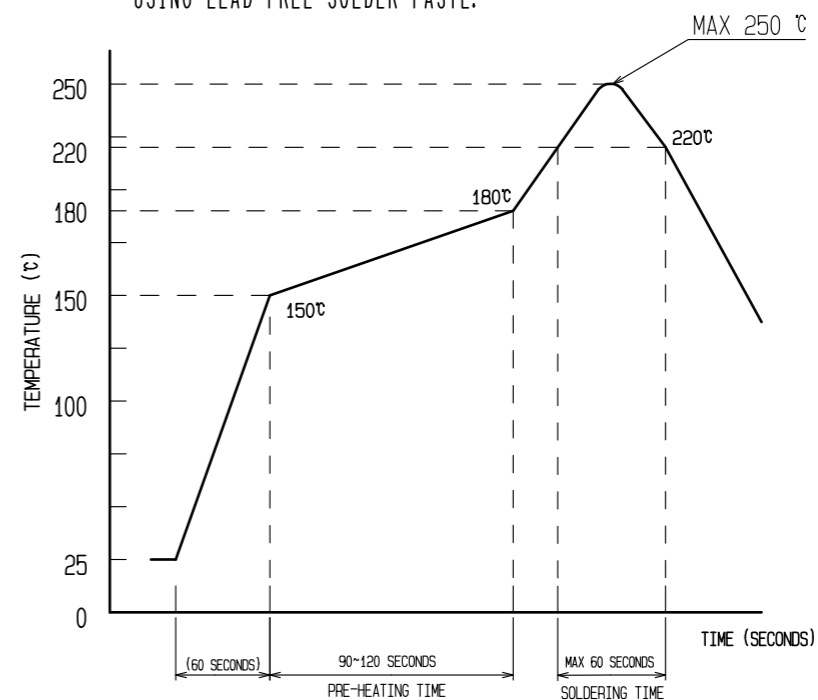

REFLOW METHOD:IR REFLOW  
NUMBER OF REFLOW CYCLES:2 CYCLES MAX.  
1)REFLOW TIME  
DURATION ABOVE 220°C.60 SEC MAX.  
(PEAK TEMPERATURE:250°C MAX)  
2)PRE-HEAT TIME  
PRE-HEAT TEMPERATURE(MIN):150°C  
PRE-HEAT TEMPERATURE(MAX):180°C  
PRE-HEAT TIME:90-120 SEC.

- 4 THIS TEMPERATURE PROFILE IS PER THE CONDITIONS SHOWN ABOVE. ADDITIONAL FACTORS, SUCH AS SOLDER PASTE TYPE, PCB SIZE AND OTHER MOUNTED COMPONENTS COULD AFFECT THE PROFILE. THEREFORE, A THOROUGH EVALUATION OF MOUNTING CONDITION IS REQUIRED PRIOR TO PRODUCTION. TEMPERATURE IS MEASURED AT CONTACT LEAD.
5. PLEASE CONTACT US IN CASE YOU WILL MAKE DIFFERENT SETTINGS FROM OUR RECOMMENDATION.
  6. THIS PRODUCT SATISFIES HALOGEN FREE REQUIREMENTS DEFINED AS 900ppm MAXIMUM CHLORINE, 900ppm MAXIMUM BROMINE, AND 1500ppm MAXIMUM TOTAL OF CHLORINE AND BROMINE.
  7. THIS PRODUCT COMPLY WITH RoHS.

HRS DRAWING FOR REFERENCE

<b>HRS</b>	DRAWING NO.	EDC-378956-51-03
	PART NO.	BM46B-12DP-0.35V(51)
	CODE NO.	CL673-7055-0-51 $\triangle$ 2/3

Nov.1.2020 Copyright 2020 HIROSE ELECTRIC CO., LTD. All Rights Reserved.  
 In case of consideration for using Automotive equipment / device which demand high reliability, kindly contact our sales window correspondents.

# EMBOSED CARRIER TAPE PACKAGING (5:1)

## STYLE AND DIMENSION OF REEL (FREE)

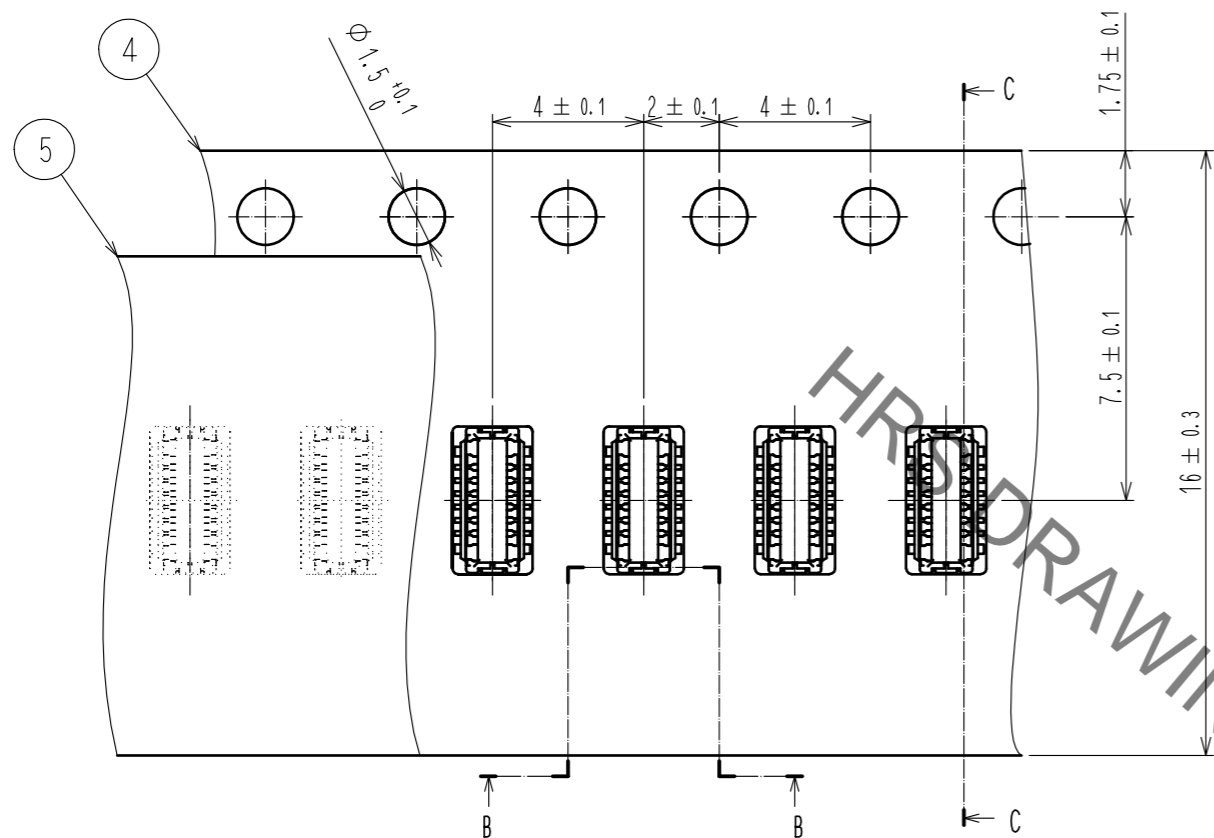

C-C (5:1)

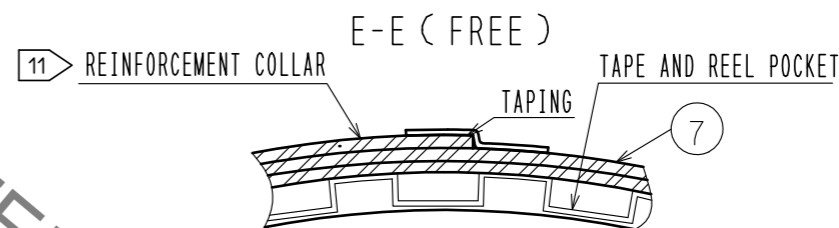
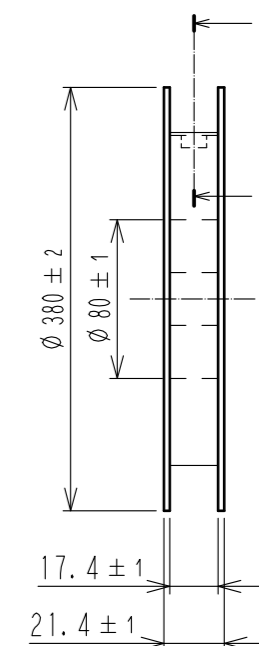
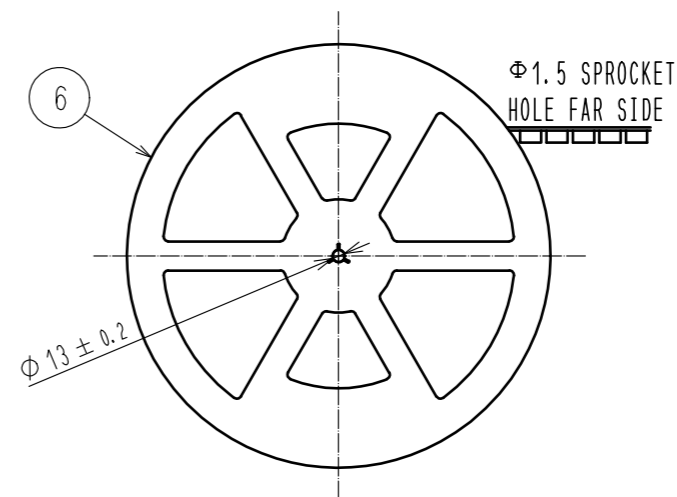
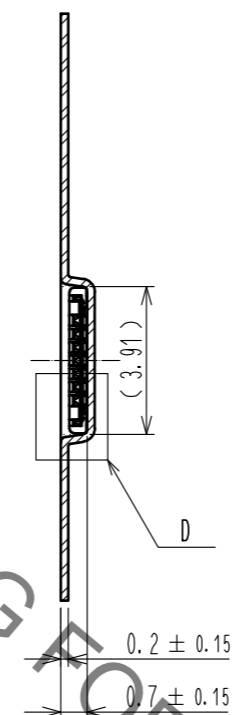

B-B (5:1)

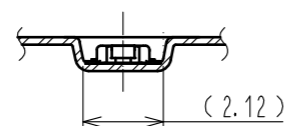

DIRECTION OF UNREELING

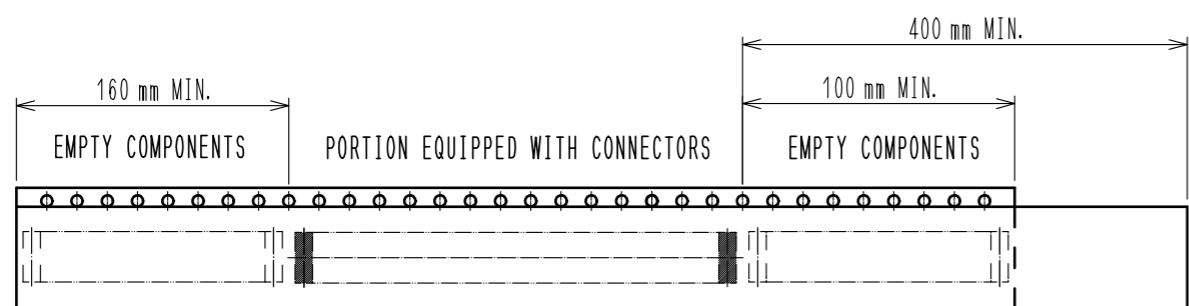
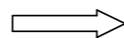

D (10:1)

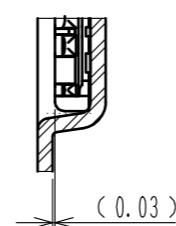

- 8 . PER REEL 20,000 CONNECTORS.
- 9 . THE DIMENSIONS IN PARENTHESES ARE FOR REFERENCE.
- 10 REFER TO IEC 60286-3 (PACKAGING OF COMPONENTS FOR AUTOMATIC HANDLING)
- 11 AFTER PACKAGING, ROLL 2 METERS OF THE REINFORCEMENT COLLAR TO OUTER CIRCUMFERENCE OF TAPE AND REEL POCKET, AND TAPE DOWN AT THE END THE COLLAR.

<b>HRS</b>	DRAWING NO.	EDC-378956-51-03
	PART NO.	BM46B-12DP-0.35V(51)
	CODE NO.	CL673-7055-0-51
		3/3