

Oct.1.2019 Copyright 2019 HIROSE ELECTRIC CO., LTD. All Rights Reserved.
 In case of consideration for using Automotive equipment / device which demand high reliability, kindly contact our sales window correspondents.

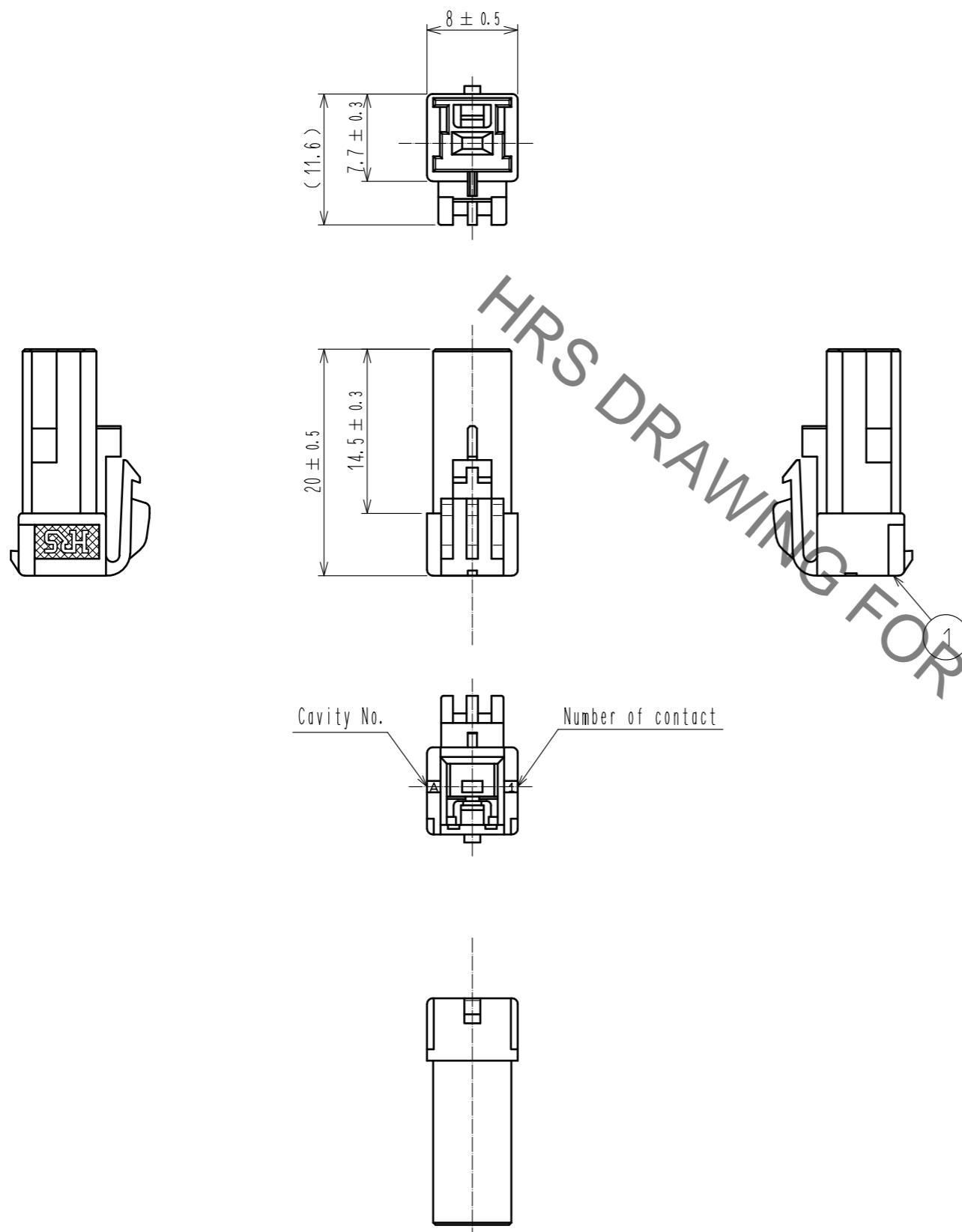

HRS DRAWING FOR REFERENCE

- 注 1. Package style : 100 pieces/pack
 2. UL<File No.E52653>
 C-UL<File No.E52653>
 TÜV<File No.R9950703>



NO.		MATERIAL		FINISH . REMARKS		NO.		MATERIAL		FINISH . REMARKS	
		1		Polyamide				Natural(White).UL94V-0			
UNITS	mm	SCALE	COUNT	DESCRIPTION OF REVISIONS			DESIGNED	CHECKED	DATE		
				2 : 1	2	DIS-H-00003575			TS. KUMAZAWA	TS. FUKUSHIMA	18.03.29
HIROSE ELECTRIC CO., LTD.		APPROVED : HS. OKAWA		17.08.24		DRAWING NO.		EDC-163201-28-00			
		CHECKED : TS. FUKUSHIMA		17.08.24		PART NO.		DF22-1S-7.92C(28)			
		DESIGNED : TO. KUROMATSU		17.08.24		CODE NO.		CL680-1012-2-28			
		DRAWN : MI. SAKIMURA		17.08.24							

Oct.1.2019 Copyright 2019 HIROSE ELECTRIC CO., LTD. All Rights Reserved.
In case of consideration for using Automotive equipment / device which demand high reliability, kindly contact our sales window correspondents.



Precautions

Notification for harness assembly

- 1) When inserting the crimping terminal to the crimping socket, please do not tilt the crimping terminal or twist the cable. Insertion at tilted angles or twisting the cable may cause deformation of the crimping terminal or crimping socket.
- 2) After inserting the crimping terminal to the crimping socket, please make sure that the lance has been hooked with pulling the cable lightly. When checking the hook, please avoid bending the cable for preventing terminal drop-off.

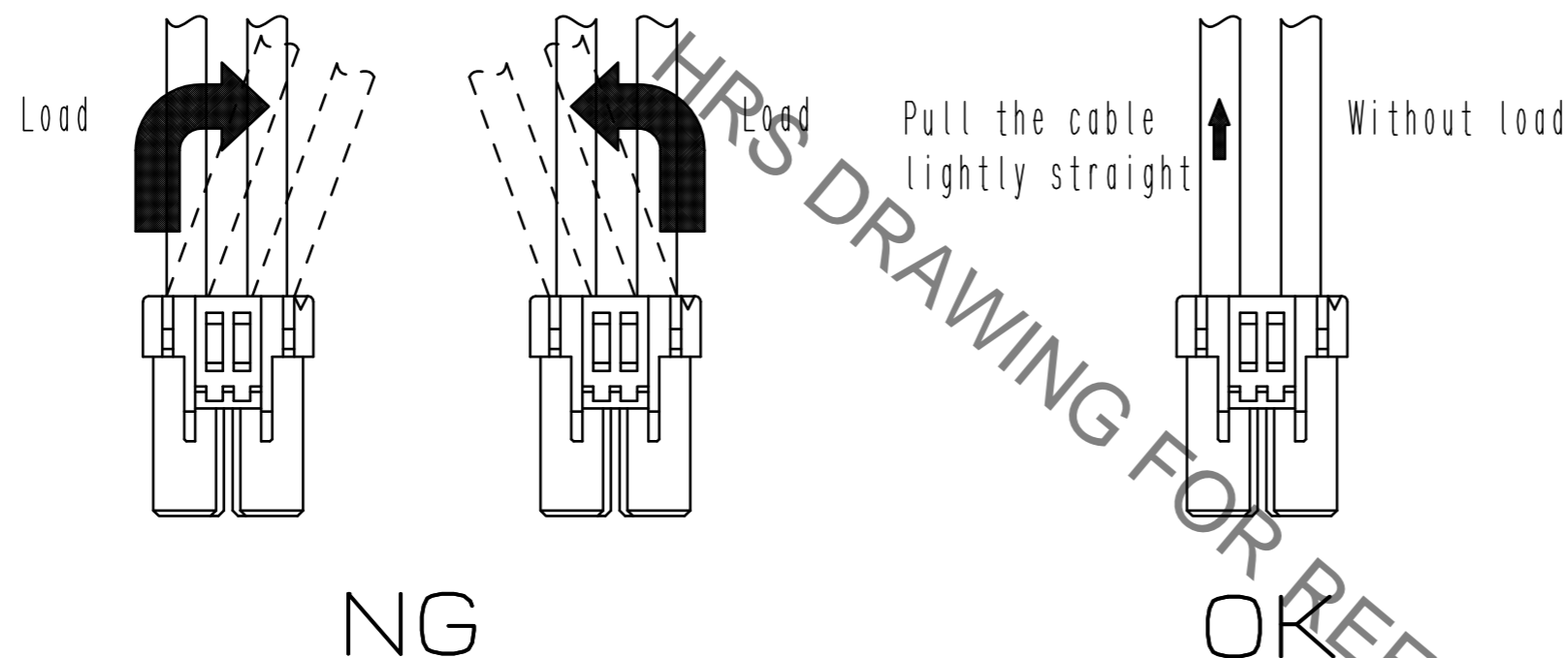

- 3) Bundle cables/Cable Cables
Recommend bundle and strip position of cables are 100 mm or more.
Bundling close to the connectors may cause terminal drop-off, breaking cables and unstable connection.

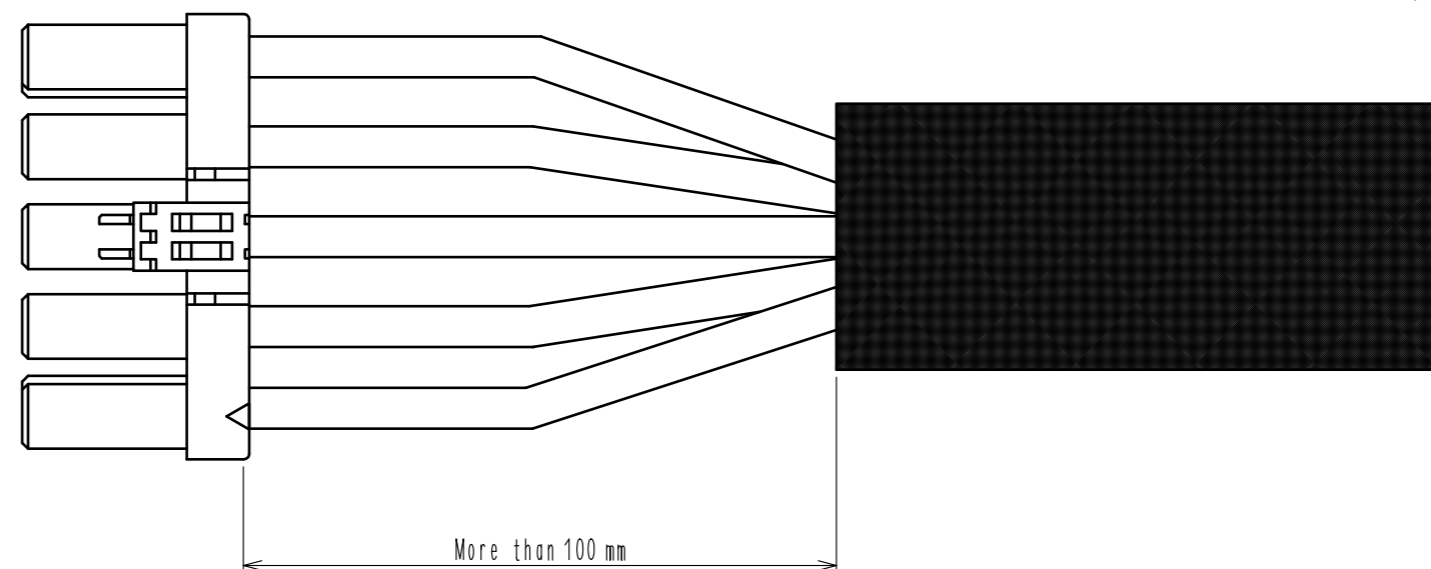

HRS

DRAWING NO.	EDC-163201-28-00
PART NO.	DF22-1S-7.92C(28)
CODE NO.	CL680-1012-2-28

Oct.1.2019 Copyright 2019 HIROSE ELECTRIC CO., LTD. All Rights Reserved.
In case of consideration for using Automotive equipment / device which demand high reliability, kindly contact our sales window correspondents.



Precautions

Notification for Insertion/Extraction

- 1) Please insert(extract) the crimping socket straight to the mating connector.
Insertion(extraction) at tilted angles applies load concentration to the connector end and may cause deformation (at connection area, socket and header case, etc). There is firing risk using this kind of deformed connector.

Insertion(Extraction)

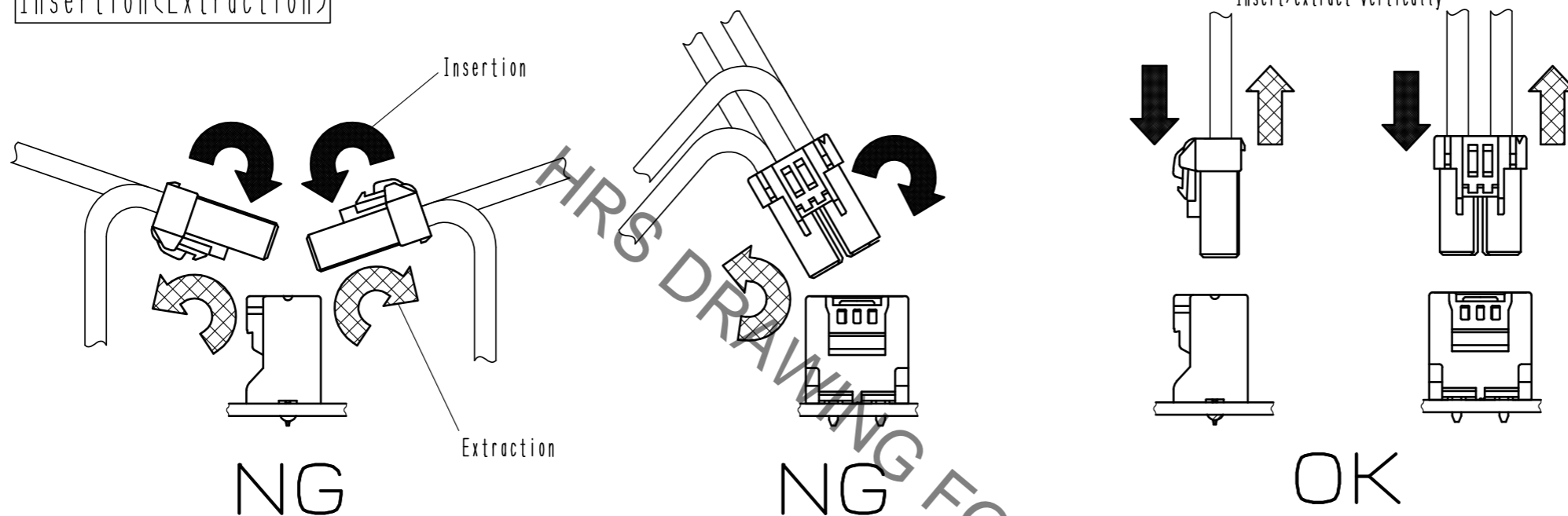

- 2) When it is hard to extract, please lightly insert the connector beforehand and then pull it with releasing the lock.
Forced extraction has a risk of connector breakage.

Notification of wiring

- 1) When using a thick cable, short cable length and bending close to the connector end, these load concentration may cause deformation.
Please note that there is firing risk using deformed connector.
When installing, please refrain from stress concentration such as cable bending close to the connector end or cable twisting.

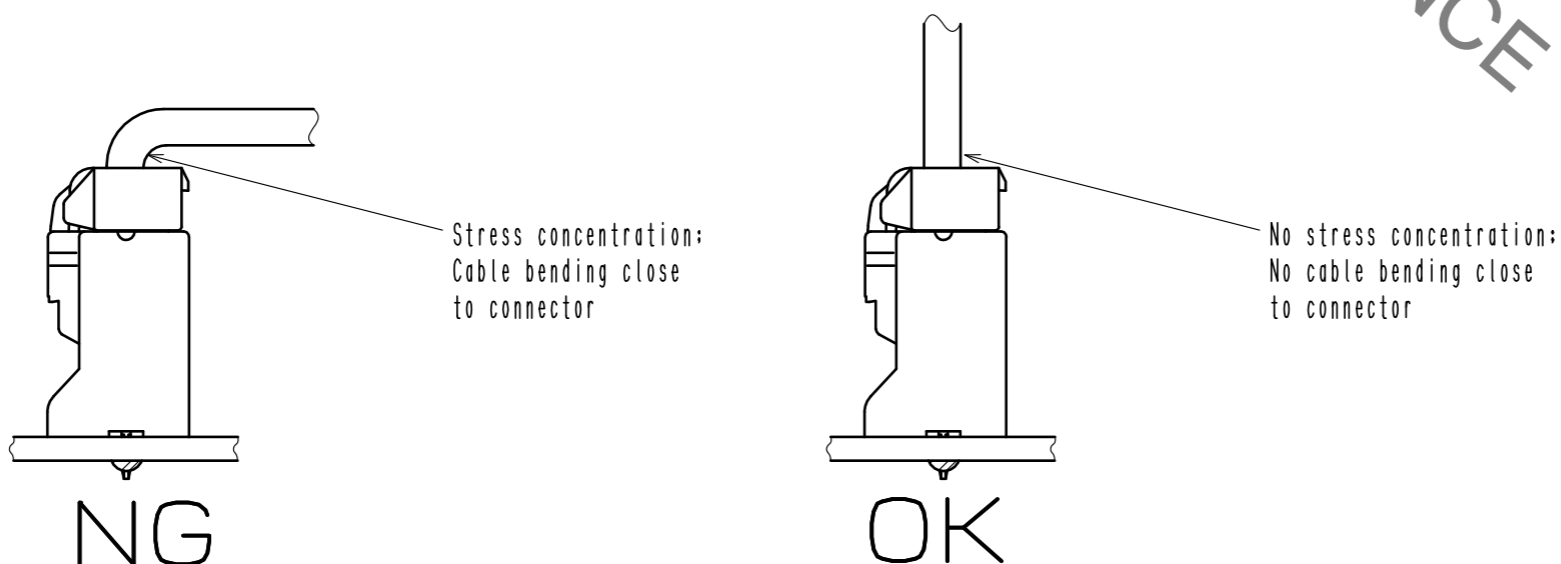

- 2) When applying load to connector end, please use the retainer for reducing the stress affection on the connector.
Retainer shall be installed after inserted crimping contact completely. It might be impossible to insert it when terminal installation is incompleated.



HRS	DRAWING NO.	EDC-163201-28-00		3/3
	PART NO.	DF22-1S-7.92C(28)		
	CODE NO.	CL680-1012-2-28		