

Apr.1.2020 Copyright 2020 HIROSE ELECTRIC CO., LTD. All Rights Reserved.  
 In case of consideration for using Automotive equipment / device which demand high reliability, kindly contact our sales window correspondents.

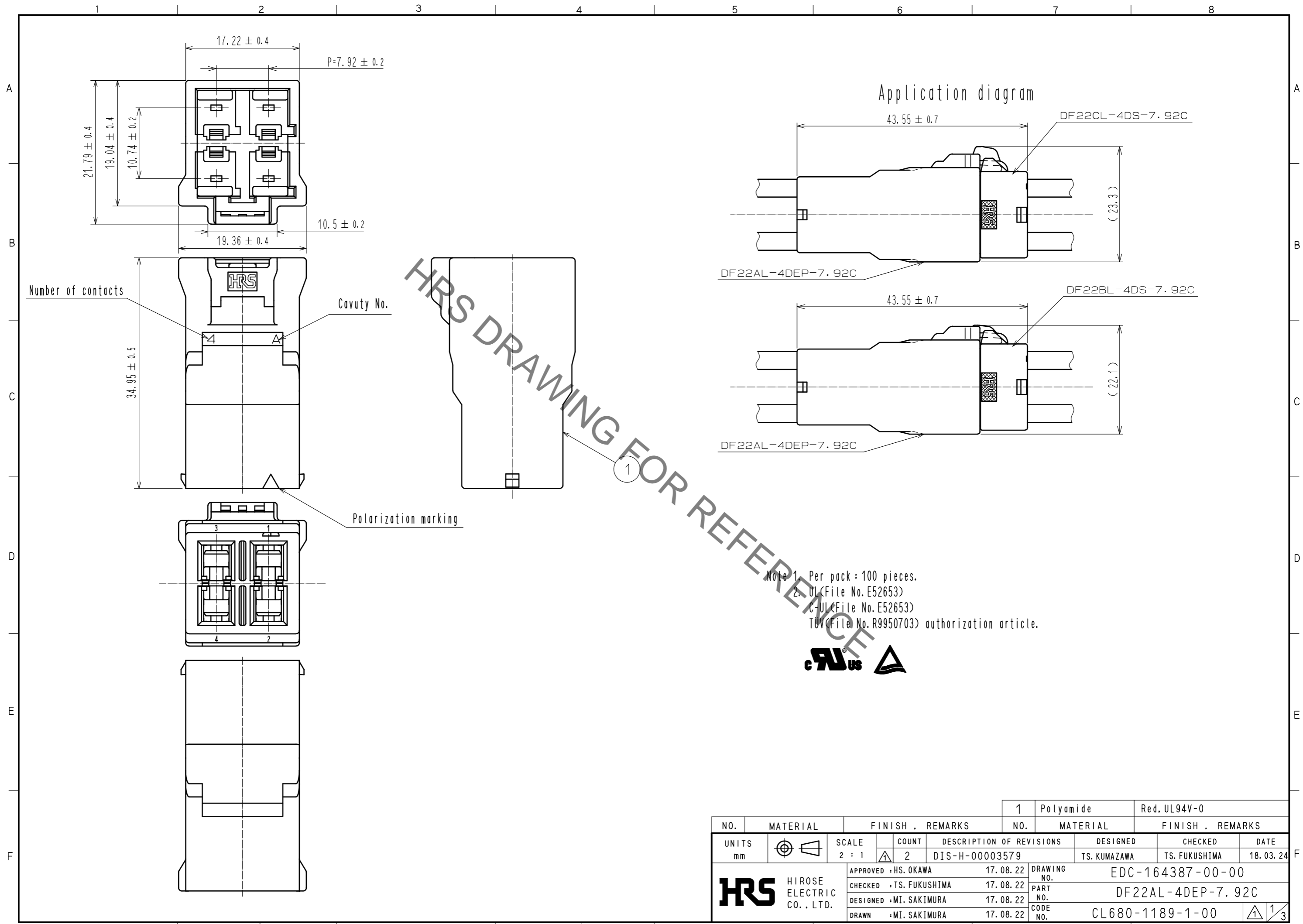

Note 1. Per pack : 100 pieces.  
 2. UL (File No. E52653)  
 C-UL (File No. E52653)  
 TÜV (File No. R9950703) authorization article.



NO.	MATERIAL	FINISH . REMARKS	NO.	MATERIAL	FINISH . REMARKS		
			1	Polyamide	Red. UL94V-0		
UNITS		SCALE	COUNT	DESCRIPTION OF REVISIONS	DESIGNED	CHECKED	DATE
mm		2 : 1	2	DIS-H-00003579	TS. KUMAZAWA	TS. FUKUSHIMA	18. 03. 24
APPROVED : HS. OKAWA			17. 08. 22	DRAWING NO.			EDC-164387-00-00
CHECKED : TS. FUKUSHIMA			17. 08. 22	PART NO.			DF22AL-4DEP-7.92C
DESIGNED : MI. SAKIMURA			17. 08. 22	CODE NO.			CL680-1189-1-00
DRAWN : MI. SAKIMURA			17. 08. 22				1/3

Apr.1.2020 Copyright 2020 HIROSE ELECTRIC CO., LTD. All Rights Reserved.  
In case of consideration for using Automotive equipment / device which demand high reliability, kindly contact our sales window correspondents.



## Precautions

### Notification for harness assembly

- 1) When inserting the crimping terminal to the crimping socket, please do not tilt the crimping terminal or twist the cable. Insertion at tilted angles or twisting the cable may cause deformation of the crimping terminal or crimping socket.
- 2) After inserting the crimping terminal to the crimping socket, please make sure that the lance has been hooked with pulling the cable lightly. When checking the hook, please avoid bending the cable for preventing terminal drop-off.

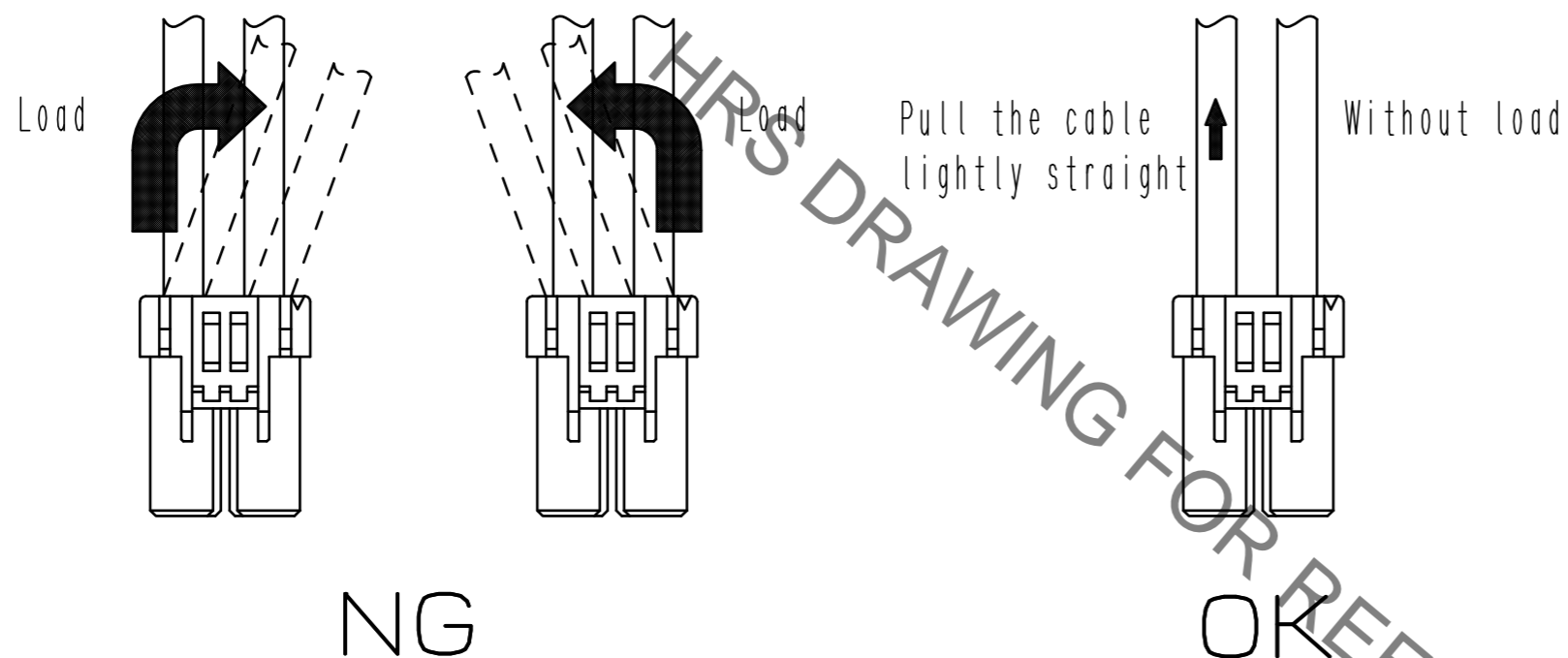

- 3) Bundle cables/Cable Cables  
Recommend bundle and strip position of cables are 100 mm or more.  
Bundling close to the connectors may cause terminal drop-off, breaking cables and unstable connection.

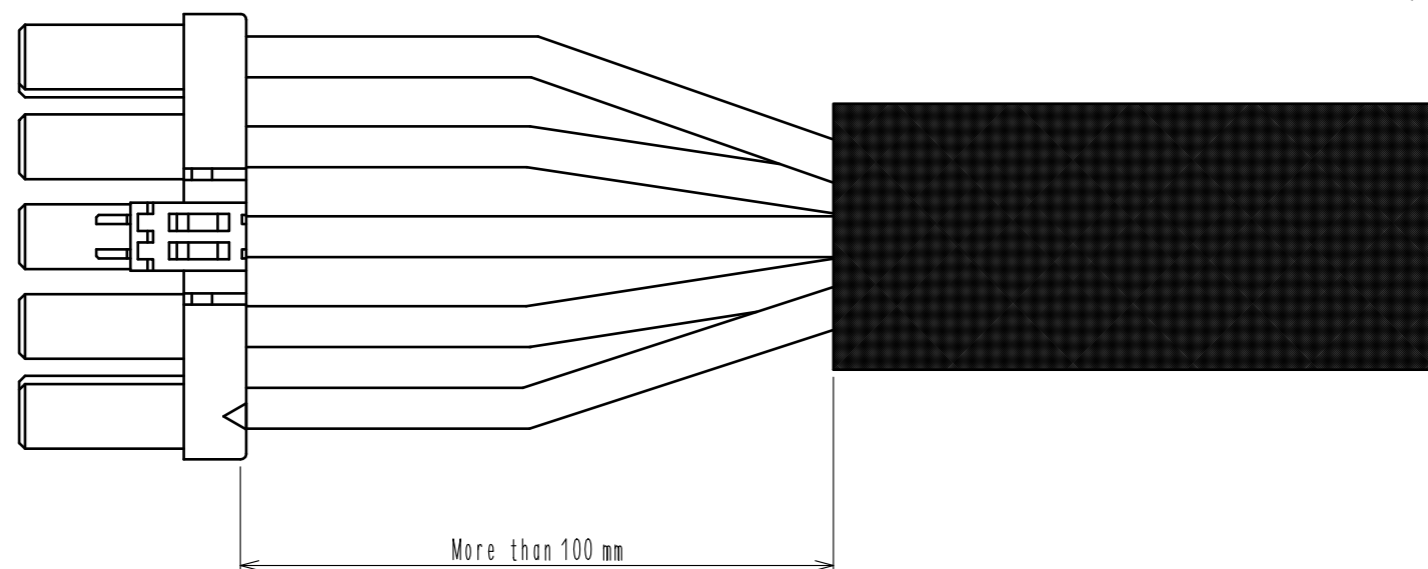

**HRS**

DRAWING NO.	EDC-164387-00-00
PART NO.	DF22AL-4DEP-7.92C
CODE NO.	CL680-1189-1-00

2/3

Apr.1.2020 Copyright 2020 HIROSE ELECTRIC CO., LTD. All Rights Reserved.  
In case of consideration for using Automotive equipment / device which demand high reliability, kindly contact our sales window correspondents.



### Precautions

#### Notification for Insertion/Extraction

- 1) Please insert(extract) the crimping socket straight to the mating connector.  
Insertion(extraction) at tilted angles applies load concentration to the connector end and may cause deformation (at connection area, socket and header case, etc). There is firing risk using this kind of deformed connector.

Insertion(Extraction)

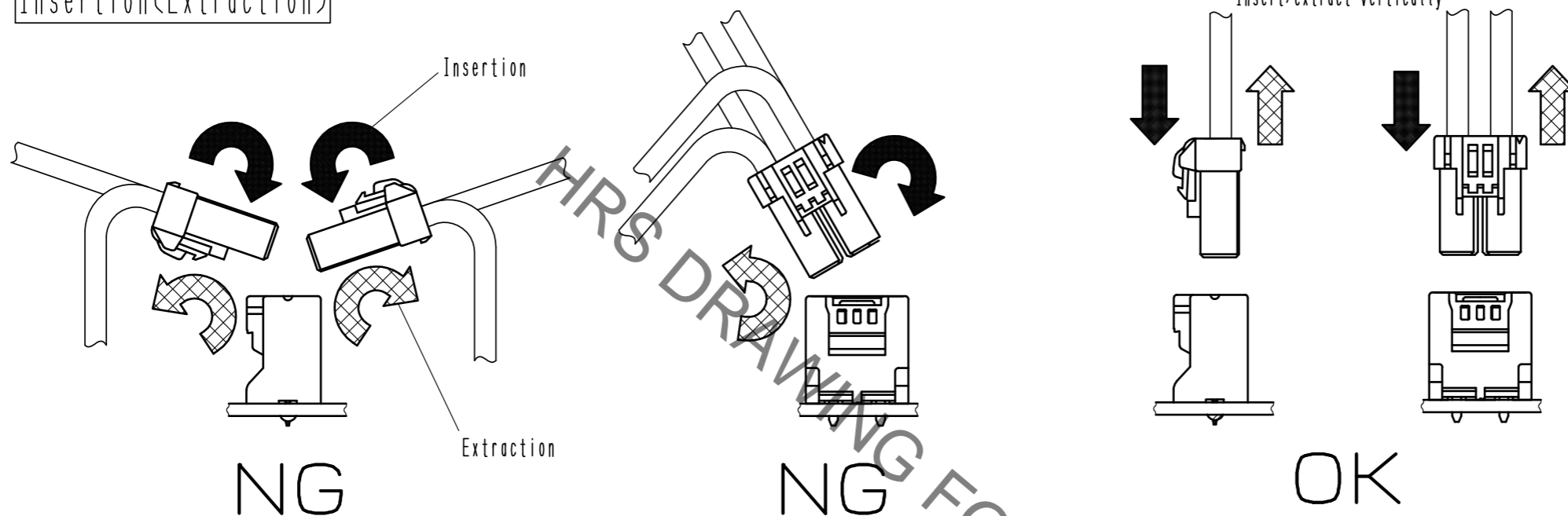

- 2) When it is hard to extract, please lightly insert the connector beforehand and then pull it with releasing the lock.  
Forced extraction has a risk of connector breakage.

#### Notification of wiring

- 1) When using a thick cable, short cable length and bending close to the connector end, these load concentration may cause deformation.  
Please note that there is firing risk using deformed connector.  
When installing, please refrain from stress concentration such as cable bending close to the connector end or cable twisting.

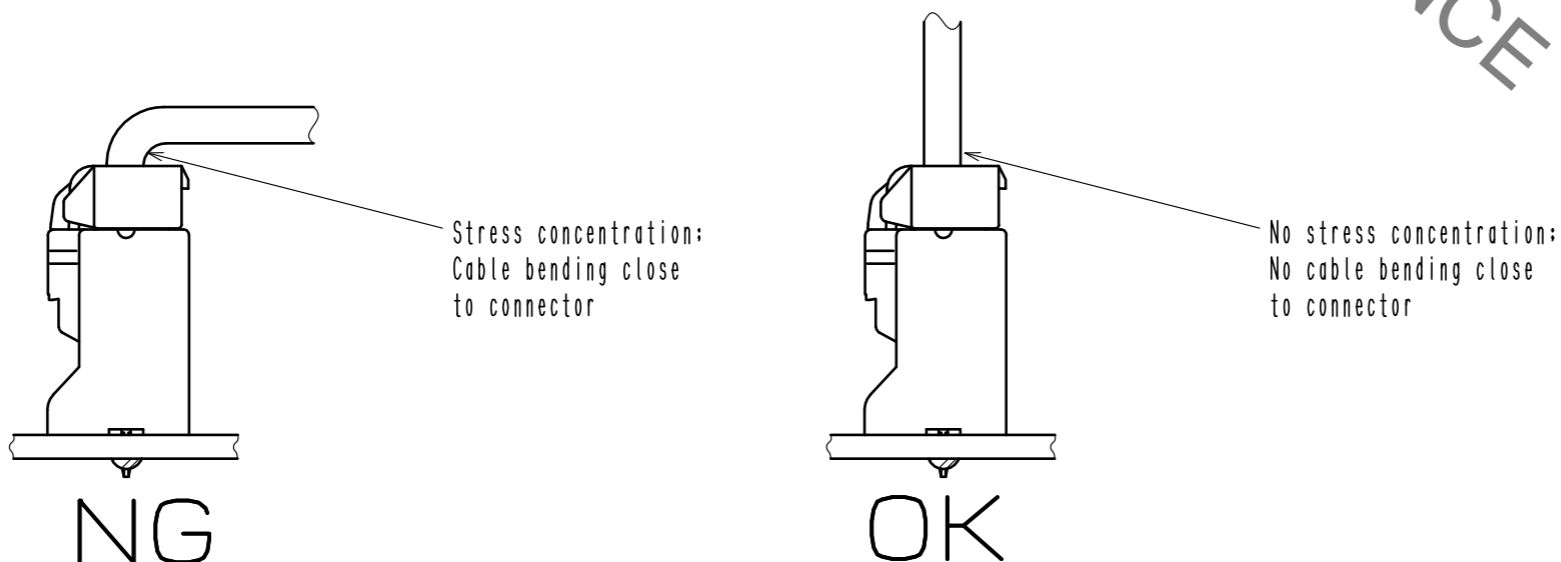

- 2) When applying load to connector end, please use the retainer for reducing the stress affection on the connector.  
Retainer shall be installed after inserted crimping contact completely. It might be impossible to insert it when terminal installation is incompleated.



DRAWING NO.	EDC-164387-00-00
PART NO.	DF22AL-4DEP-7. 92C
CODE NO.	CL680-1189-1-00